

स्वा में,
सहायक
जी. एस. एफ. कारीपुर
द्वारा -
परिष्कृत सहायक
अभियन्ता कारीपुर, अम्बाजारी
नागपुर.
डिस्ट्रिक्ट कारीपुर
कॉट नं.

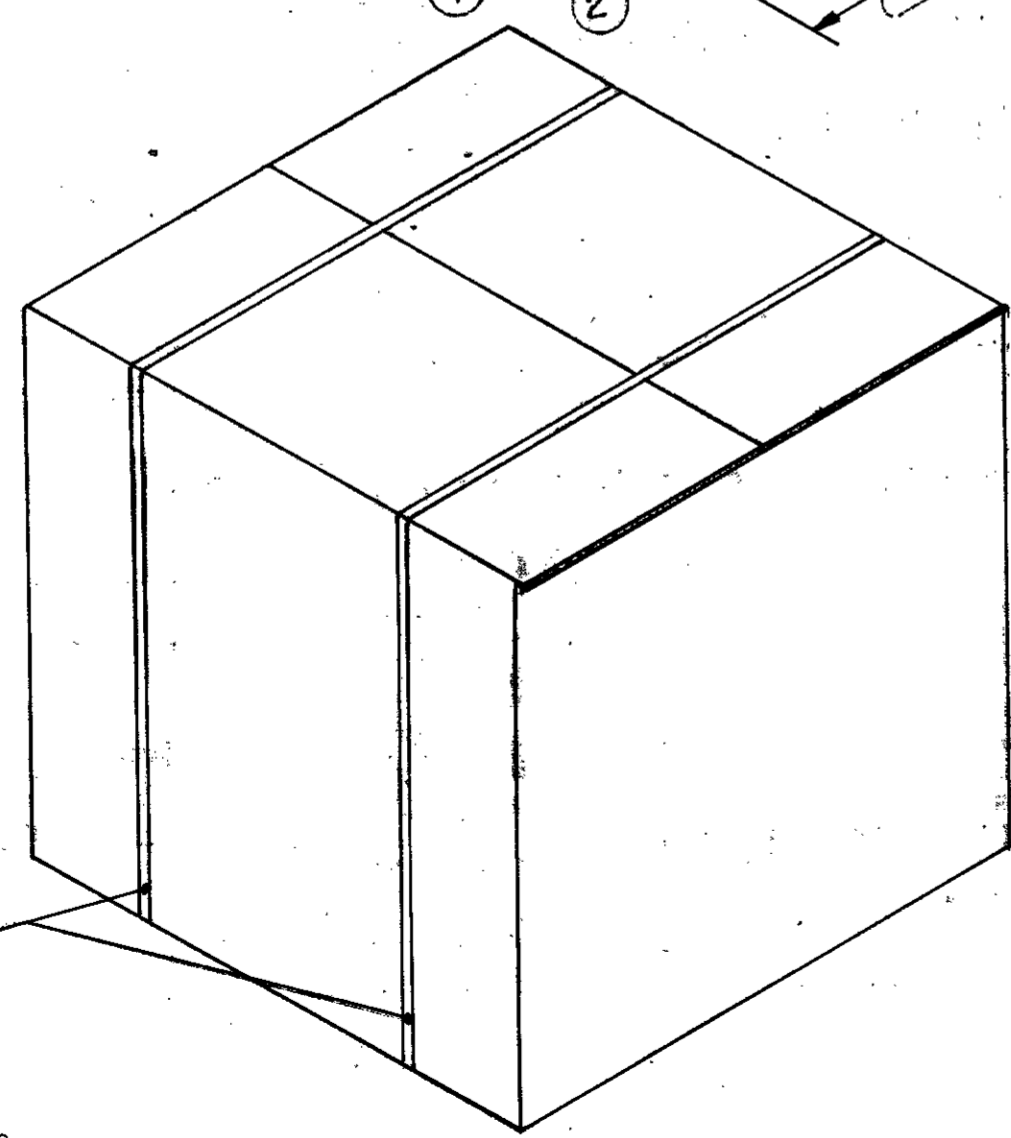

TIED WITH NYLON TAPE
(NOT TO BE SUPPLIED BY
BOX SUPPLIER)

Box in Closed Condition

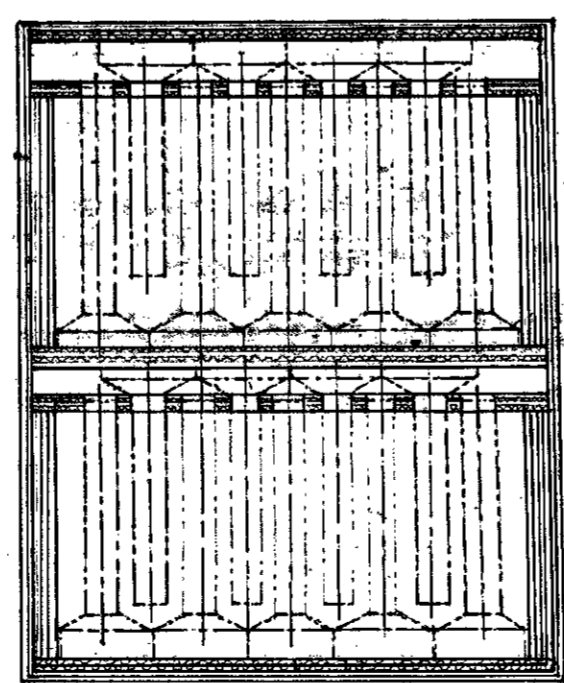
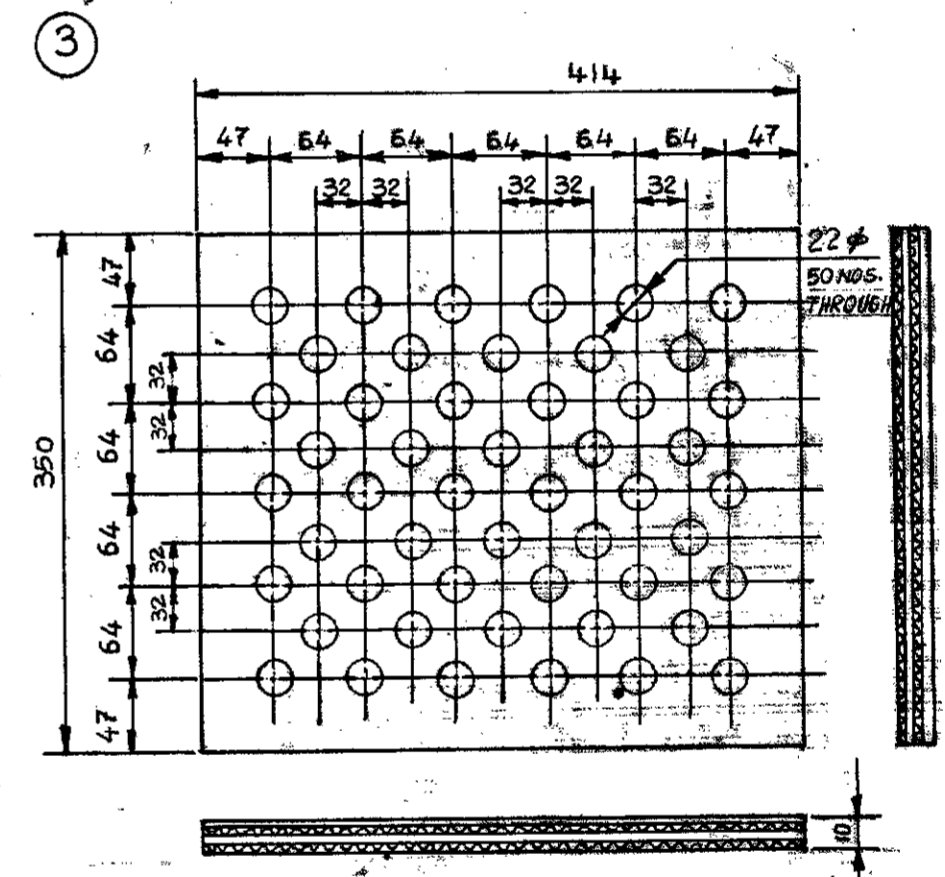
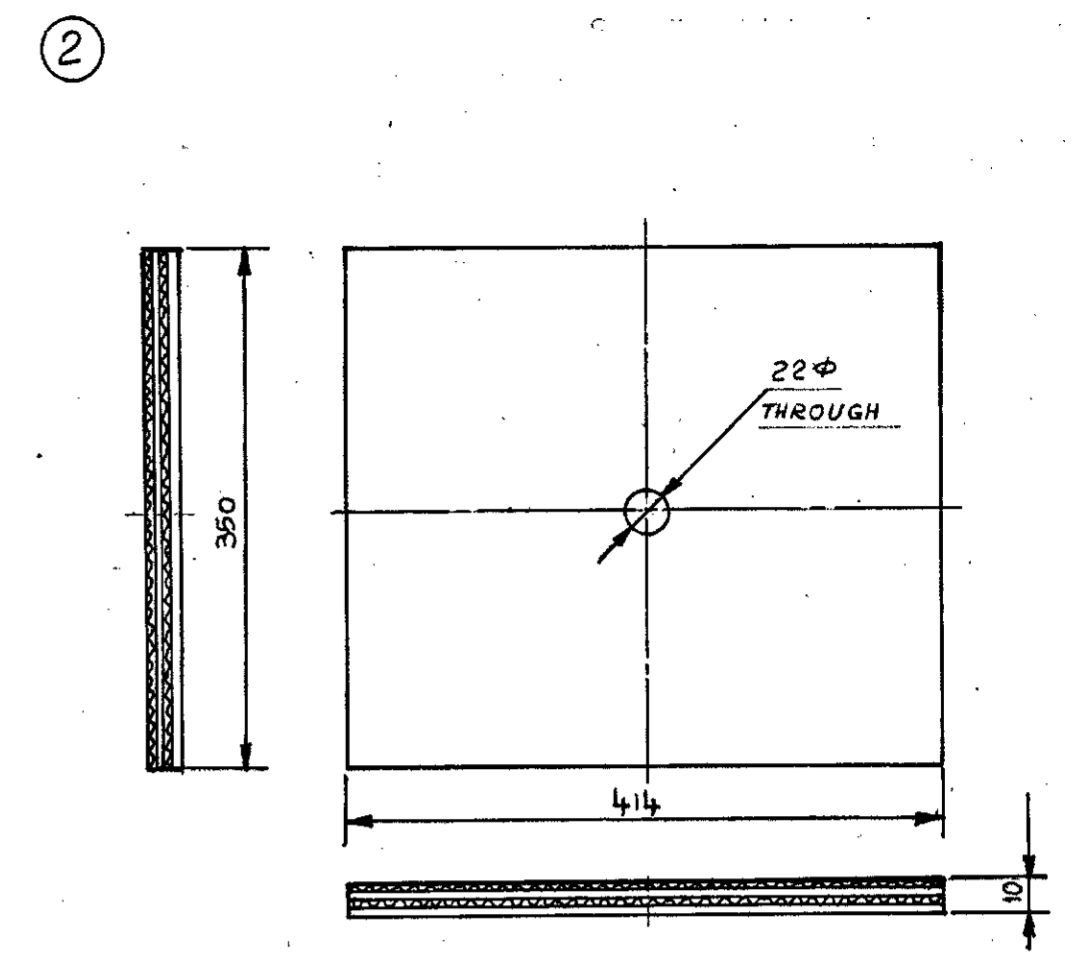
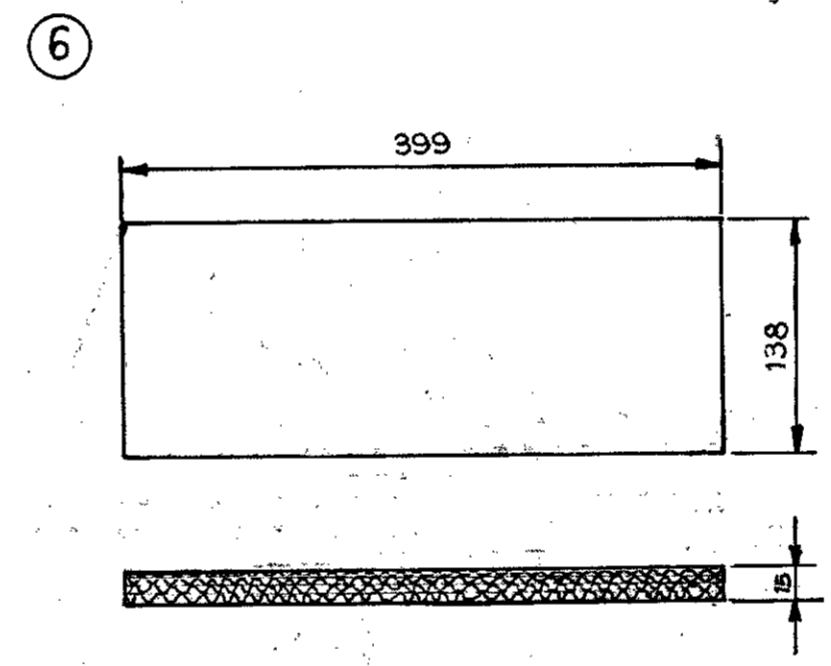
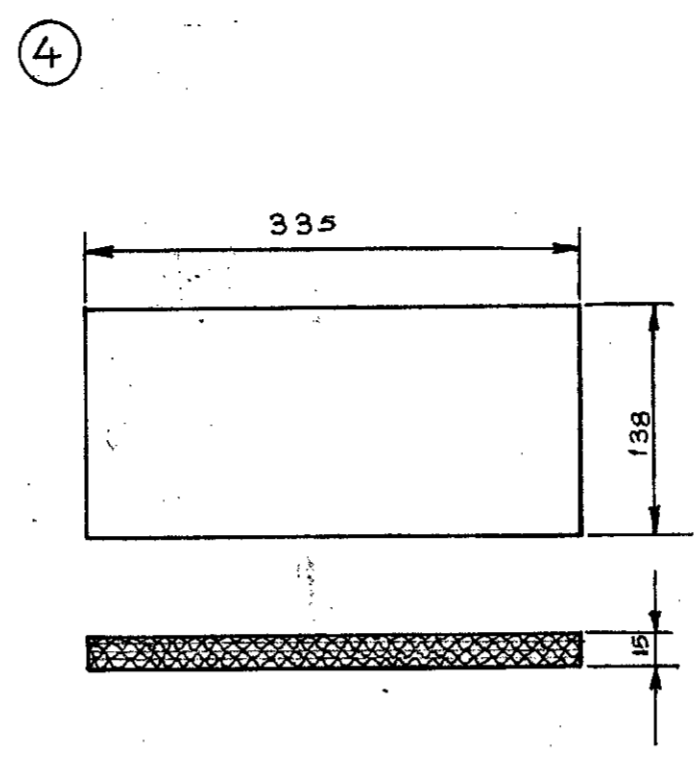

PACKING METHOD

- NOTE:
- MATERIAL FOR PART NO. 1.
150 GSM KRAFT PAPER, 9 PLYS, DOUBLE WALL CONSTRUCTION, VERTICAL NARROW FLUTING AND 8mm THICK.
 - MATERIAL FOR PART NO. 2 & 3
150 GSM KRAFT PAPER, 9 PLYS, 4 WALL, NARROW FLUTING, 10mm THICKNESS AND CROSS FLUTED I.E. ALTERNATIVE FLUTES SHOULD RUN ACROSS EACH OTHER AS SHOWN IN THE SIDE VIEWS.
 - MATERIAL FOR PART NO. 4 & 5.
120 GSM KRAFT PAPER, 13 PLYS, 6 WALL, NARROW & VERTICAL FLUTING & 15mm THICKNESS.
 - EACH BOX IS TO HOLD COMPONENTS OF MASS 20kg MIN
 - THE COMPLETE BOX WHEN TESTED FOR SUBSTANCE SHOULD HAVE A TOTAL MASS OF MIN. 2.3kg. (OWN WT)
 - THE BOXES AND PARTS TO BE MARKED WITH THE MANUFACTURERS NAME/INITIALS OR TRADE MARK.
 - GENERAL WORKMANSHIP AND FINISH SHALL BE GOOD THROUGHOUT
 - WHEN MIN. SIX LOADED CARTONS ARE STACKED THE BOX SHOULD NOT DISTORT OR BUCKLE.

NOTE: ALL PARAMETERS ARE GOVERNED BY THE SPECN. IS: 2771 (Pt. I) LATEST ISSUE & SUBJECT TO PROPER BEHINDING OF THE PARTS.

PART	DESCRIPTION	NO. OF PARTS	MIN. WT	BURSTING STRENGTH	REMARK
5	SHOCK ABSORBER (BIG SIDE)	4			
5	STAPLES, MS GALVANISED 12X30X8mm AS REQD.				
4	SHOCK ABSORBER (SMALL SIDE)	4			
3	MOUTH SUPPORT	2			
2	SHOCK ABSORBER (TOP, MIDDLE & BOTTOM)	3			
1	PACKING BOX.	1	MIN. 9kg/cm ²		

DIMENSIONS ARE IN mm		MATERIAL - AS ABOVE		ORDNANCE FACTORY	
THIRD ANGLE PROJECTION				AMBAJHARI	
SCALE: 1:1	SCALE: 1:1	NOMENCLATURE		DRAWING NO.	
DATE	DATE	CORRUGATED FIBREBOARD		CC-536 B	
NAME	NAME	PACKING CARTON		SHEET NO.	
DESIGN	DESIGN	FOR 100 BLANKS		NO. OF SHEET	
CHECKED	CHECKED	SCHEDULE NO.		OPERATION NO.	
WM/CDD	WM/CDD	STORE CG		COMPT. TPT DISTANCE	
WM/CCS	WM/CCS			TUBE BLANK CC-536	
REV	DATE	DESCRIPTION		AMENDMENTS	
88/15	01/06	NOMENCLATURE PACKING CARTON			
B	2015	WAS PACKING BOX			
37/14	20/02	IN NOTE NO: 4, 20kg WAS 15			
A	2014	IN NOTE NO: 5, 23kg WAS 1.9kg			