

16313-W SCH. SEALED PROV.
22-4-85

16707-W PROV. SEALING
6-12-88 CANCELLED

SIZE	ZONE	REF. No.	PART No	NOMENCLATURE	Qty	REMARKS
				MATERIALS		
		7		EPOXY COMPOUND		
				GRADE 3PK ASPER		
				TECH. SPEC FOR ARTICLE		
				2A46.		

ORIGINAL INVENTORY SIGNATURE AND DATE

INSTEAD OF INVENTORY No.

DUPLICATE INVENTORY No.

SIGNATURE AND DATE

174-97-W
28-12-92

SCH SEALED PROV.

kgv
CID

ALL SHEET	No. OF DOCUMENT	SIGNATURE	DATE
-----------	-----------------	-----------	------

2A46. CS 21-16

(64)

SHEET
2

30

2A46 CB 21-16 CB 18-490V 4-AD63-81 2-A0777-95

FIRST ANGLE PROJECTION

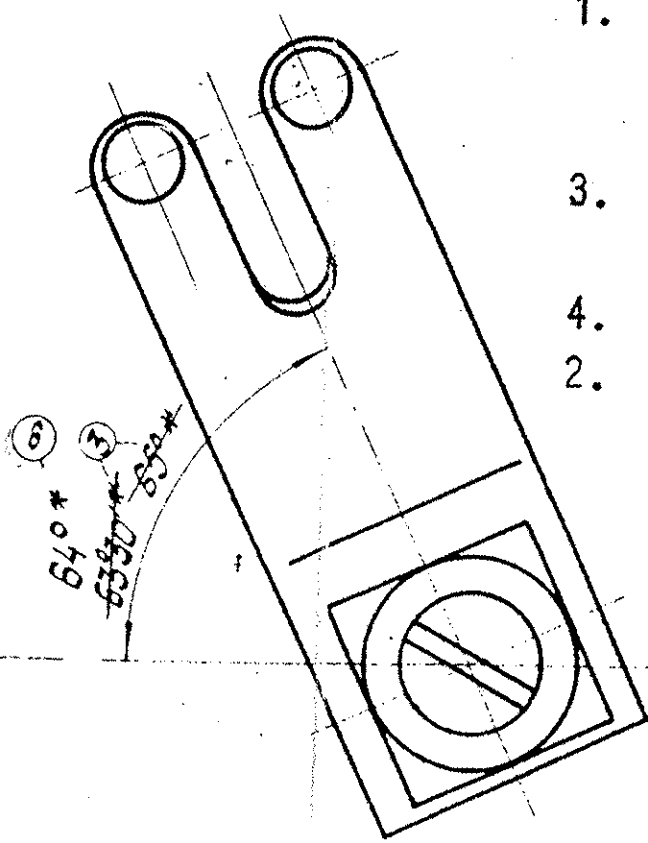
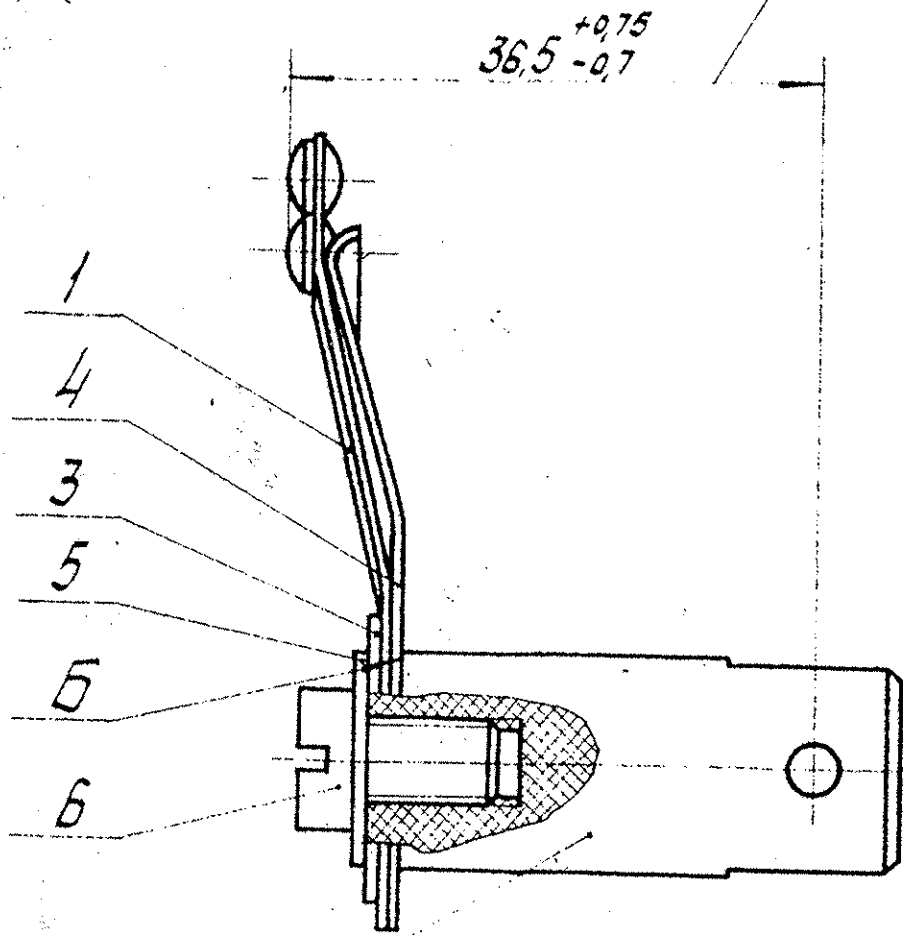

1. Dimension A is to be ensured by selection of thrust plates 4 or filing of surface B of slider 2.
3. Mark the index of the article and part number, on the tag.
4. * Dimension for reference.
2. Apply compound (Item 7) to set bolt 6.

1. Размер А обеспечить подбором пластин упорных поз. 4 или припиловкой поверхности Б ползуна поз. 2.
2. При сборке резьбу винта поз. 6 покрыть клеем поз. 7.
3. Маркировать индекс изделия и обозначение детали на бирке.
4. * Размер для справок.
2. Установку винта поз. 6 производить на компаунде поз. 7.

जाची गई सही प्रति
CERTIFIED CORRECT COPY OF
मुद्रित रेखाचित्र की
SEALED DRAWING AS OW

FOR CONTROLLER OF QUALITY
आश्वासन (क वा आ) अवडि चेन्नै 54
ASSURANCE (AVA) AVADI CHENNAI 54

18814-W 22-10-03	HINDI NOMEN ADDED	
17497-W 28-12-92	DRG SEALED PROV.	
16707-W 6-12-88	PROV. SEALING CANCELLED	
16313-W 22-4-85	DRG SEALED PROV	

DSCAT No. 5325-008819		
2A46. CB 21-16 CB		
कॉन्टैक्ट स्लाइडर CONTACT SLIDER असेम्बली ड्राइंग Assembly drawing		
0971-AVA 11-01-11	DSCAT No. ADDED	
ISSUE	DATE	REFERENCE
APPROVED		
CHECKED		
DRAWN		
MATERIAL.		
SHEET	MASS	SCALE
1 of 1	0.023	2:1
C.Q.A (AVA) AVAD		

6 436 1382

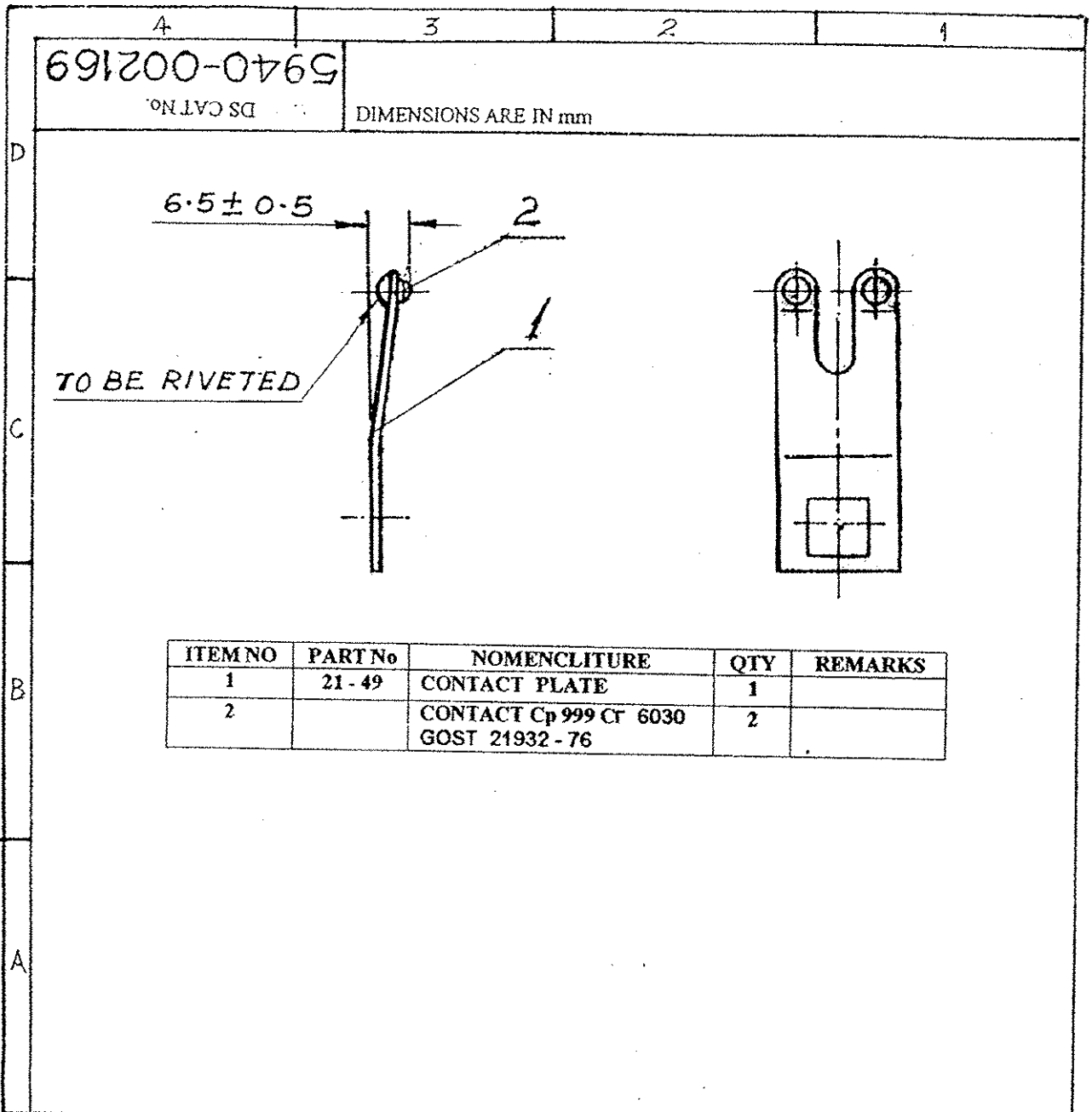

ITEM NO	PART No	NOMENCLITURE	QTY	REMARKS
1	21-49	CONTACT PLATE	1	
2		CONTACT Cp 999 Cr 6030 GOST 21932 - 76	2	

					CQA(AVA) AVADI	
22/03	10814-W		HINDI NOMEN. ADDED.	103	DRN	CHD <i>[Signature]</i>
9-10-03			POLY NEG. PREPARED.		APPROVED	AHSP
			PREV. DC 16313-W, 17068-W & 17088-W, DT. 4-7-91			DO FOR CQAW
DATE	AUTH	ZONE	NATURE	SIG DO	ASSLY DRG.	
AMENDMENTS						
DRG SEALED :- 17068-W DT. 7-5-91					DESIGN No.	
SCALE 1/1 ESTD MASS 0.008 DATE					PART No. 2A20C821-17	
MATL					DS CAT No. 5940-002169	
कांटेक्ट प्लेट CONTACT PLATE						

(129)

2446.21-46

18-5904
SL-LLD-81

FIRST ANGLE PROJECTION

A-A

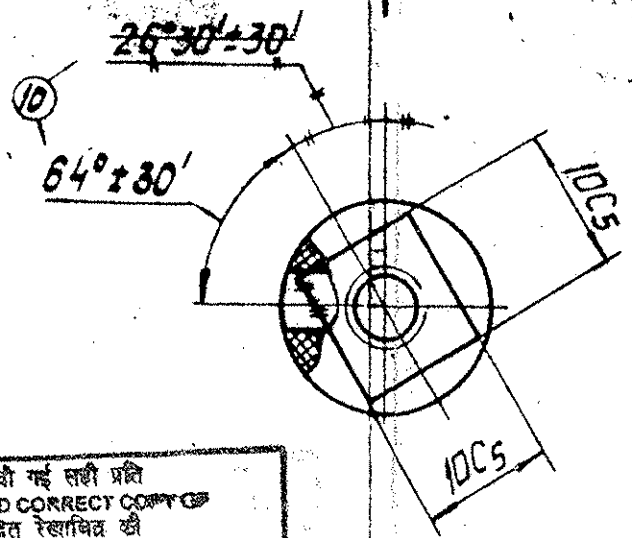
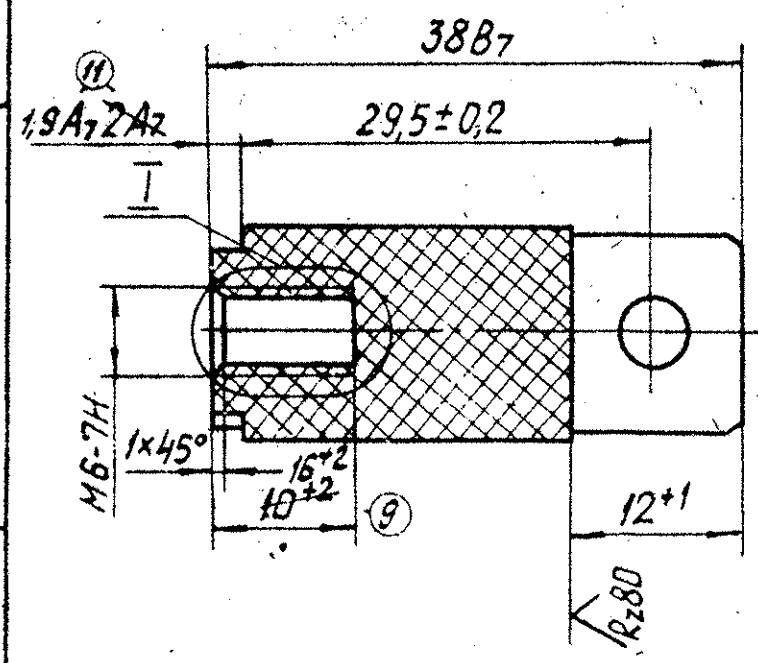

जांची गई सही प्रति
CERTIFIED CORRECT COPY
मुद्रित रेखाचित्र की
SEALED DRAWING AS ON

FOR CONTROLLER OF QUALITY
आश्वासन (क या आ) अवधि चेन्नै 54
ASSURANCE (AVA) AVADI CHENNAI 64

1x45°

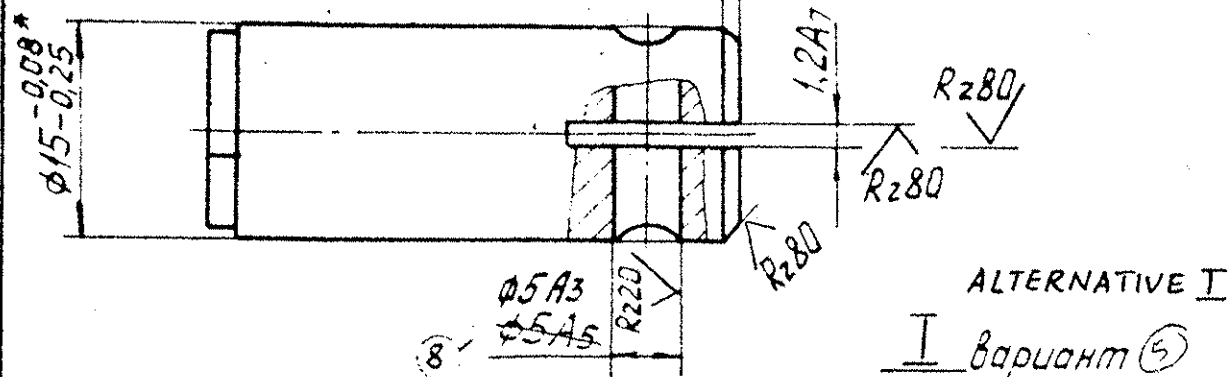

ALTERNATIVE I
I вариант

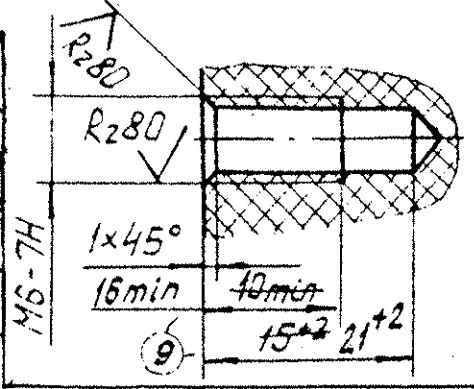

18607-W ALT. MATL 2-1-2001 AMENDED.	MSA/DRC
17058-W PROV SEALING CANCELLED 7-5-91 & DRG SEALED.	149V/CBGO
17561-W 2-4-93 INDIGS ALT MATL ADDED.	149V/CJD
17497-W 28-12-92 DRG SEALED PROV.	149V/CJD
16707-W PROV. SEALING 6-12-88 CANCELLED	
16313-W 22-4-85 DRG SEALED PROV	

17068-W PROV SEALING CANCELLED AND 7-5-91 DRG SEALED.

INDIGENOUS ALTERNATIVE
BAKELITE HYLAM GRADE G-II NEMALI 1-1977
GLASS FIBRE FILLED PHENOLIC MOULDING MATERIAL GRADE 'A' TO SPECN. IND/ME/951 (PROV)
FIBER GLASS RESIN MOULDED GRADE 'A' MATERIAL TO SPEC IND/ME/951 (PROV)

- * After moulding dimension is controlled in 100% of the components.
- Other technical requirements as per OST 3-4223-79.
- Mark letter "4" on the tag.
- Alternate material: moulding material АГ -4В GOST 20437-75.

- * После прессования размер контролировать на 100% деталей.
- Остальные технические требования по ~~№ 5643-68~~ OST 3-4223-79
- Маркировать 4 на бирке.
- Заменитель материала Пресс-материал АГ-4В ГОСТ 20437-75

CHANGE OF MATERIAL :- MATERIAL OF SLIDER CHANGED FROM 'FIBRE' TO 'CHINA CLAY'

11	U38. 1386	24 55	DSCAT No. 5325-008820		
10	112P 1285 177	12 26	130 2A46. 21-46.		
007-AVA 11-01-11 DSCAT No. ADDED			SHEET	MASS	SCALE
1 5-8-92 CQA(W) L/No. 50817-CQAW(W) Dt. 27 OCT. 90.			1 of 1	0.008	2:1
ISSUE	DATE	REFERENCE	SLIDER		
APPROVED		23/1/92	MATERIAL: MOULDING MATERIAL DCB-2-P-2M GRADE O. GOST 17478-72.		
CHECKED		26/6/92	C.Q.A(AVA) AVADI		
DRAWN		20/6/92			

21-50

89676-V

▽ остальное

FIRST ANGLE PROJECTION

▽ unless otherwise specified.

ALT. MATL:--

SHEET TO IS: 1079-86 GDE Fe 410 OR BS:1449

Pl 1:83 GDE 22 HS

*

РАЗНОЖЕНЕ ВОСПРЕЩАЕТСЯ

10707-W PROV. SEALING
6-12-88 CANCELLED

17068-W PROV SEALING CANCELLED &
7-5-91 DRG SEALED

18010-W ALT MATL AMENDED.
30-7-94

17633-W ALT MATL & PHOSPHATING
29-5-93 NOTE ADDED.

16913-W DRG SEALED PROV
22-4-85

DS CAT No. ADDED.

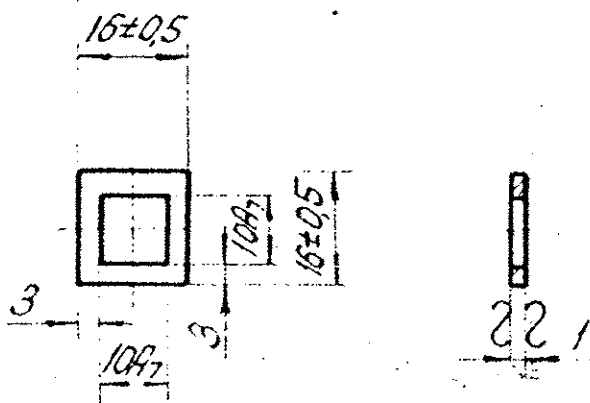

1. Sheet 5 -1 GOST 19903-74.
2. Internal angles $R \approx 0.4\text{mm}$.
3. Blunt sharp edges, $R \approx 0.6\text{mm}$,
4. Coating: Chemical phosphating, chromium, oil finished.

* COATING:-- PHOSPHATING TO JSS: 0465-01 CLASS II, FINISH 13 (g)

DS CAT No. 5310-239541

8 10

2- 1 Гост 16523-70

174 97-W 28-12-92		DRG SEALED PROV.	NSV C/D	2A20
94 WASHER			21-50	78
ISSUE	DATE	REFERENCE	SHEET	MASS
APPROVED			1 of 1	0.0013
CHECKED			SCALE	1:1
DRAWN			C.Q.A(AVA)AVADI	
MATERIAL:		STEEL 25 cm 3 cn GOST 16523-70		

16707-W PROV SEALING 6-12-88 CANCELLED
 16313-W DRG SEALED PROV 22-4-85
 18010-W ALT MATL AMENDED 30-7-94
 19607-W ALT MATL AMENDED 2-1-2001
 7-5-91 CANCELLED & DRG SEALED
 1991-V s/p

РАЗМЕРНЫЕ ВОСПРЕДЕЛЕНИЯ

21-53



89676-7

1 unless otherwise specified.

FIRST ANGLE PROJECTION

▽1 ОСТАТОЧНОЕ

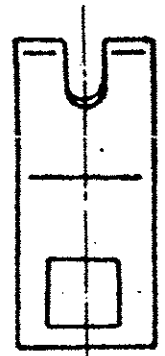

DEVELOPED VIEW

Развертка

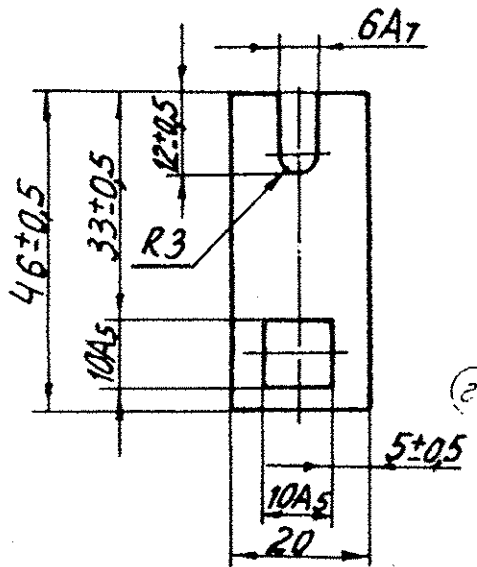
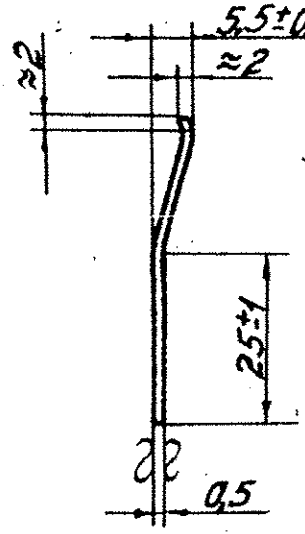

ALT MATL:- IS:2507-75 DESIGNATION 55
 Si 7 Gr 9 WITH S AND P RESTRICTED
 TO 0.35 EACH.

OR
 BS:1449 (Pt-1)-83 SECTION 4 Gde 60
 CS (En 43 J)

HARDNESS:- TO BE HARDENED TO
 HRC 54-58.

COATING:- CHEMICAL PHOSPHATING
 TO ISS:0465-01 CLASS-II.

ADHESIVE WITH THE FOLLOWING
 REQUIREMENT:- SOLUTION OF
 POLYVINYLE ACETONE AND RESOL
 PHYNOL FORMALDEHYDE RESIN
 IN ALCOHOL.

- Strip 0.5 x 20 GOST 2263-69.
- Radius of bend $R \approx 1\text{mm}$
- Internal angles $R \approx 0.4\text{mm}$
- Blunt sharp edges, $R \approx 0.6\text{mm}$
- Harden. HRC = 54-58, H5 73-76.
- Coating: chemical phosphating, hastened, chromium adhesive 4 or 6-2 with nigrosine Black (3 layers)
- Technical requirements as per H0 3607-61, GROUP 2.

DSCAT No. 9515-013955

174-97-W 28-12-92		DRG SEALED PROV.	2A20	
0071-AVA 11-01-11		DS CAT No. ADDED	21-53	
17768-W 20-10-93		ALT MATL AMENDED	SHEET	MASS
17717-W 14.9.93		ALT MATL & COAT- ING NCTE ADDED.	1 of 1	0.003
ISSUE DATE		REFERENCE	SCALE	1:1
APPROVED	<i>[Signature]</i>	22/10/92	C.Q.A(AVA)AVADI	
CHECKED	<i>[Signature]</i>	22/11/92		
DRAWN	<i>[Signature]</i>	21/6/92		
		MATERIAL:		
		STEEL 60 C2		
		GOST 2283-69		

КОМПЛЕКТ ТРОЧУК

400MOT 11

AR-3