

41926 / 7490314252

2

THIS DOCUMENT AND THE INFORMATION CONTAINED IN IT ARE PROPRIETARY AND CONFIDENTIAL TO OFT. NO PERSON OR ENTITY IS ALLOWED TO COPY, REPRINT, REPRODUCE OR PUBLISH ANY PART OF THIS DOCUMENT. NOR DISCLOSE ITS CONTENTS TO OTHERS, NOR MAKE ANY USE OF IT, NOR ALLOW OR ASSIST OTHERS TO MAKE ANY USE OF IT UNLESS BY THE PRIOR WRITTEN EXPRESS AUTHORIZATION OF OFT AND THEN ONLY TO THE EXTENT AUTHORIZED.  
 COPYRIGHT-OFT.

NOTES:

1. INTERPRET THIS DRAWING IAW ASME Y14.100M.
2. MATERIAL: CRES BAR TYPE 303 PER ASTM-A-582.
3. UNLESS OTHERWISE SPECIFIED, UNDEFINED MACHINED FILET RADIUS SHALL BE 0.2, 0.3.
4. DEBURR AND REMOVE SHARP EDGES, APPROX. 0.2X45 Deg.
5. GENERAL TOLERANCES ACCORDING TO ISO 2768-mi.
6. A DRY FILM LUBRICATION IN A FLUOROPOLYMER ORGANIC RESIN CLASS 2 COLOR MATTE BLACK TYPE I, 5-13 MICRON THICK PER VS-1-3-1-165 (OR EQUIVALENT).
- 6.1. PROTECT THREAD AFTER PASSIVATION.
7. QUALITY ASSURANCE PROVISIONS:  
 7.1. QUALITY ASSURANCE PROVISIONS FOR THIS ITEM PER RDM000012P
8. PARENTHEICAL FIGURES ARE FOR REFERENCE ONLY.
9. PACKAGING AND PACKING: THE FINISHED PART SHALL BE PRESERVED AND PACKAGED IN ACCORDANCE WITH MANUFACTURERS BEST COMMERCIAL PRACTICE.
10. IDENTIFY PER MIL-STD-130 PARA 4.1.B, BY LABELING ITS CONTAINER WITH THE PART NUMBER CHARACTERS MINIMUM TEXT HEIGHT 1.25 MM.

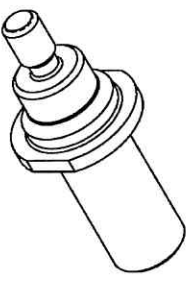

(WEIGHT: 0.01 Kg APPROX.)

2

DWG NO. Y17398A-00	
SHEET REV RECORD	
ALL SHEETS ARE THE SAME REVISION	

REV	ECO	DESCRIPTION	DATE	APVD
01		Identical To Previous	09-Apr-18	L. Goldstein
		Restricted	06-Jul-17	E. Iizovitch
		Released		

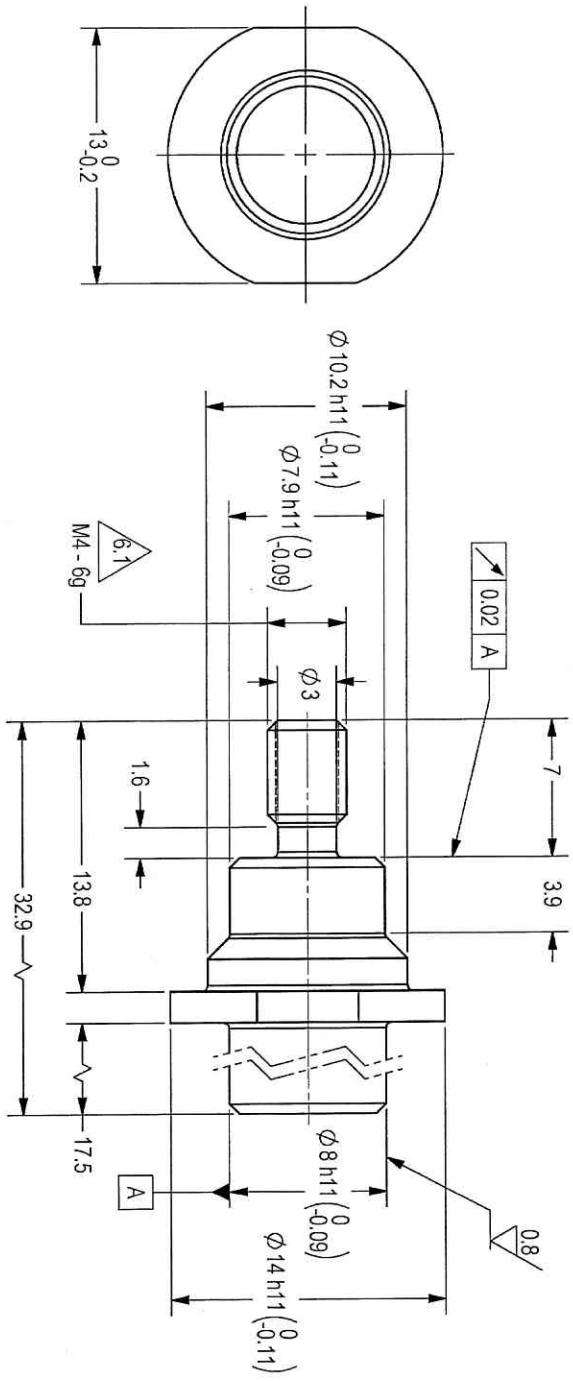

30.11.2020

32 / (0.8)

SEE ATTACHED MEDIA

UNLESS OTHERWISE SPECIFIED		DRAWN		SIGNATURE		DATE	
DIMENSIONS ARE IN MM PER ASME Y14.5M-1994		M4		M4		11/20	
TOLERANCES		CHECKED		HOSIDDO		3/9/20	
LINEAR SEE NOTE 5		OFFICER/PRODN		OFFICER/PRODN			
ANGULAR SEE NOTE 5		OFFICER/PRODN		OFFICER/PRODN			
1st ANGLE PROJECTION		OFFICER/PRODN		OFFICER/PRODN			
SURFACE TEXTURE IN Micro Meter		OFFICER/PRODN		OFFICER/PRODN			
PROJECT OFFICER		PLM Control		OFFICER/PRODN		OFFICER/PRODN	



ORDNANCE FACTORY THIRUVIRAPPALLI

TITLE: EXTENSION SOLENOID  
 FOR: SOLENOID SHOT ASSY  
 OF: 12.7MM SRGC

SIZE: B  
 CAGE CODE: 2291A  
 DWG NO: Y17398A-00  
 SCALE: 4:1  
 AUTOMATED DRAWING (SM)  
 SHEET 1 OF 1

1

A