

SAF CONFIDENTIAL

COPY No. 1

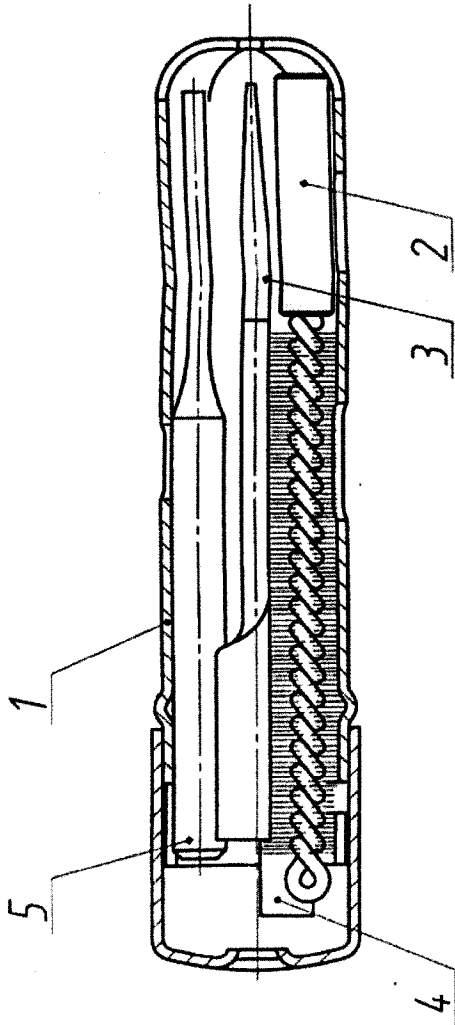

S.NO.	NOMINCLATURE	DRAWING NO.
1.	CONTAINER ASSY. (i) BODY (ii) CAP	SK-6602 TE SK-6603 TE SK-6604 TE
2.	BRUSH ASSY. (i) BRUSH SUB ASSY. (ii) SLEEVE	SK-6605 TE SK-6606 TE SK-6607 TE
3.	SCREWDRIVER	SK-6608 TE
4.	PULL THROUGH	SK-6609 TE
5.	DRIFT	SK-6610 TE

Arrangement of components inside container is optional.

सर्वप्रथम की जात प्रमाणित  
 प्रमाणित किया गया है  
 Hos / P/M/2  
 Certified as correct copy  
 of drg. on.....16/10/23.....  
 5/1  
 11/10/23  
 DRG. NO. SK-6601 TE  
 12/10/23

Weight: 74g	
DRAWN	CHECKED
DATE 12/10/2023	APPROVED
HOS/000	
DRG. NO. SK-6601 TE	
SHT. 1 OF 1	
7.62x39mm AR-SAF Accessories in container Assembly drawing	
SCALE M T S	SMALL ARMS FACTORY KANPUR

SK-6602 TE

DRG. NO.

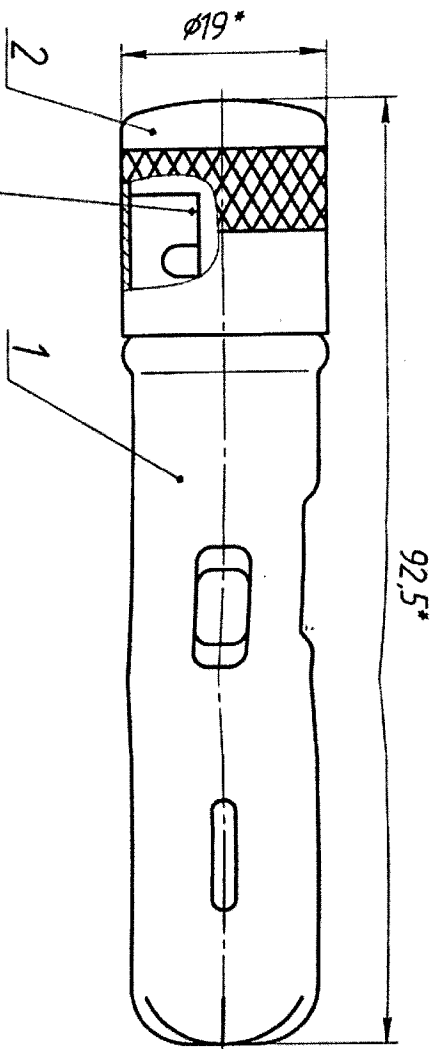

For tight fit it is allowed to open up lugs of body pos. 1

SAF CONFIDENTIAL  
COPY No. 1

S. NO.	NOMINCLATURE	DRAWING NO.
1.	BODY	SK-6603 TE
2.	CAP	SK-6604 TE

- 1 \*Reference dimensions
- 2 Ensure that cap pos. 2 can be rotated by hand relative to body pos. 1.

HOS/MSW  
 Confirmed as per copy copy  
 of des. on 16/10/23  
 Dr. Nagesh Kumar  
 Sr. Manager  
 16/10/23

SCALE NTS		SMALL ARMS FACTORY KANPUR	
7.62X39mm AR-SAF Container Assembly drawing			
DRAWN		SEEN BY	
DATE		APPROVED	
12/30/2023		HOS/MSW	
DRG. NO.		SMT.	
SK-6602 TE		1 of 1	
Weight: 418g			

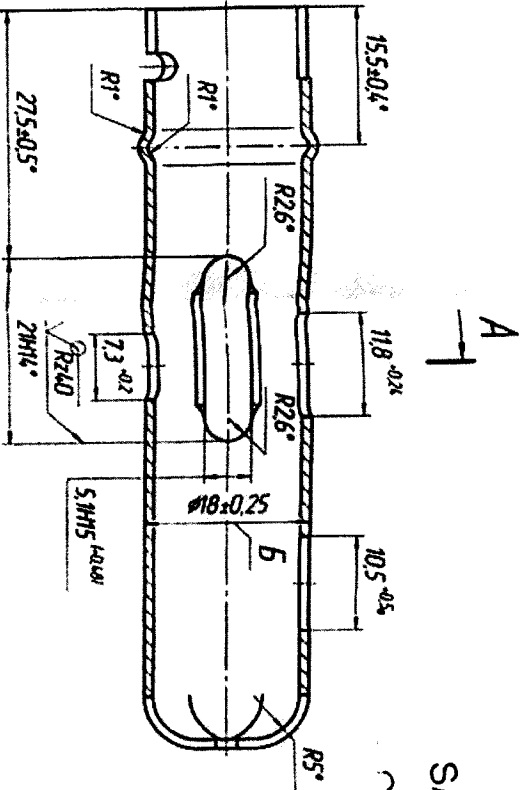

SAF CONFIDENTIAL  
COPY NO. 1

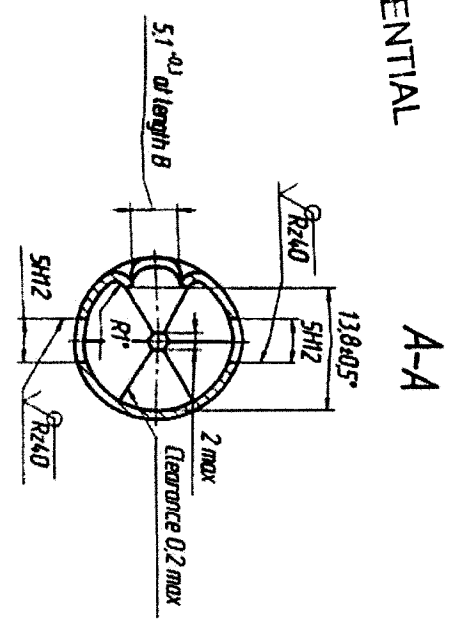
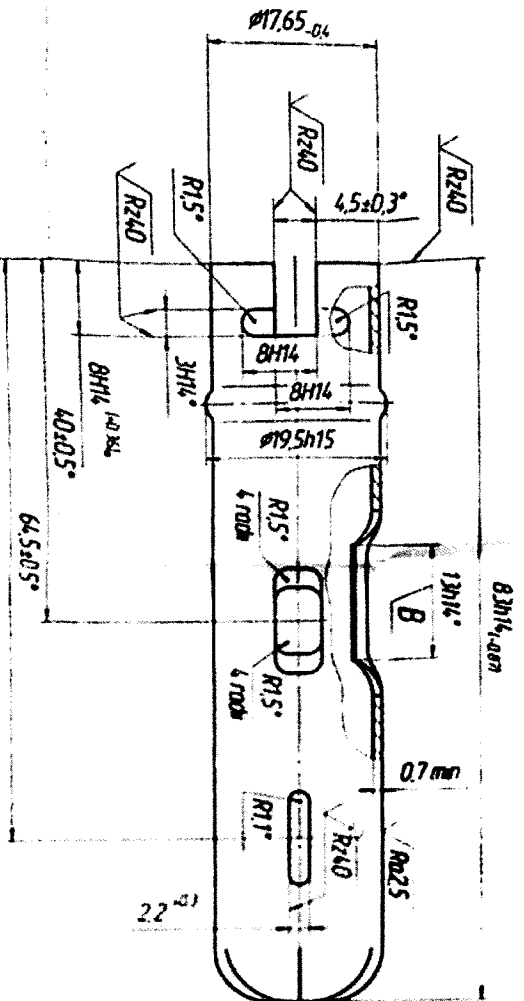

SK-6603 TE

- 1 65 71 HRA
- 2 At forming and cutting section dimension B is allowed to be not greater than 18.5 mm
- 3 Dimensions to be ensured by tool
- 4 Loading is Chem Phos chr/Impreg with 50-4 glue
- 5 Appearance according to control sample

16/10/2023  
 Certified as correct copy  
 16/10/23  
 J. Works Manager  
 16/10/23

MATL- Tube 18x1 GOST 9567-75  
B35 GOST 8733-74

7.62X39mm AR-SAF

Body

SCALE	NTS	
SMALL ARMS FACTORY		
KANPUR		
Weight: 31g		
DRAWN	SEEN BY	CHECKED
DATE	12/10/2023	
APPROVED		
DESG. NO.	SK-6603 TE	
HOS/000		

✓✓✓

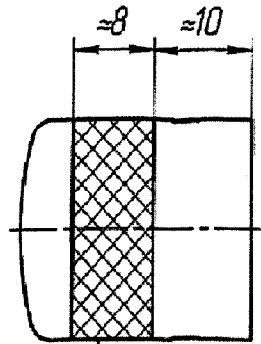
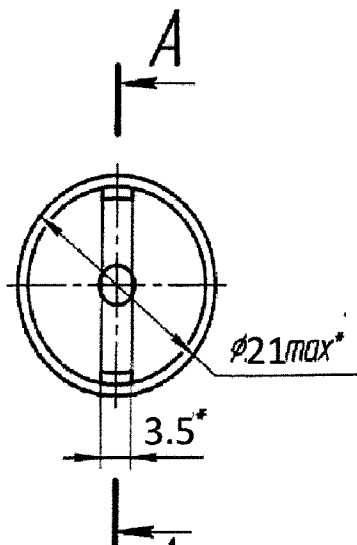

Diamond knurling 1,6  
GOST 21474-75

SAF CONFIDENTIAL  
COPY No. 1

A-A

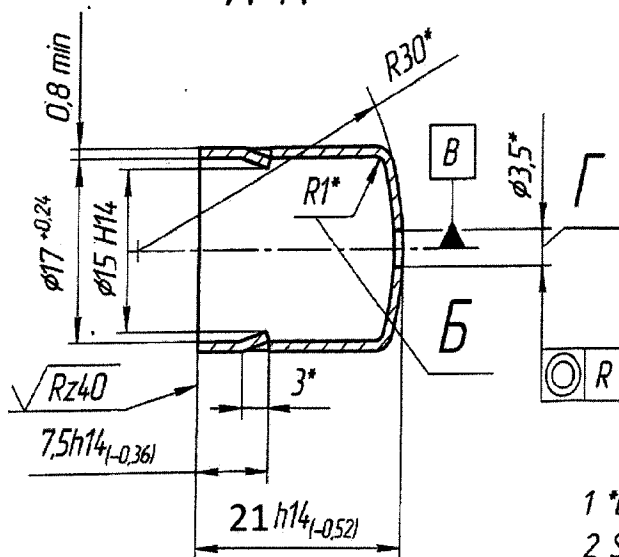

होज/मम  
आरेखण की सही प्रमाणित  
प्रतिलिपि दिनांक.....  
Certified as correct copy  
of drg. on... 16/10/23  
क. कार्यालया प्रबन्धक  
Jr. Works Manager  
डी.डी.ओ.  
DDO

- 1 \*Dimensions to be ensured by tool
- 2 Straight knurling 1 GOST 21474-75 is allowed
- 3 Thickness reduction at radius 5 portion is allowed.
- 4 It is allowed to make hole Γ when developed.
- 5 Coating is Chem. Phos. chr/impreg. with 5Φ-4 glue GOST 12172-2016 with nigrosine of grade A GOST 9307-78.

MATL. - Strip 15-HO-1,5x40  
GOST 2284-79

Weight 10,8 g

**7.62x39mm AR-SAF  
CAP**

DRAWN TRACED CHKD.

S P SONI

DATE 11.10.23

APPROVED

HOS/DDO

DRG.NO.

SK-6604 TE

SCALE  
N.T.S

**SMALL ARMS FACTORY  
KANPUR**

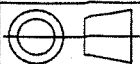

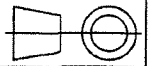

SCALE  
N.T.S.

SMALL ARMS FACTORY  
KANPUR

SK-6605 TE

DRG. NO.

HOS/DDO

Brush  
Assembly drawing

# 7.62x39mm AR-SAF

APPROVED

DATE

S P SONI

DRAWN TRACED CHKD.

Weight 4.5 g

1\* Dimensions to be ensured by tool.  
2\* Dimensions for operation adjustment.

S. NO.	NOMINATURE	DRAWING NO.
1.	BRUSH SUB ASSY.	SK-6606 TE
2.	SLEEVE	SK-6607 TE

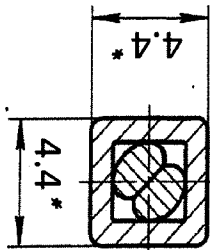

A-A (5:1)

Four-sided swaging

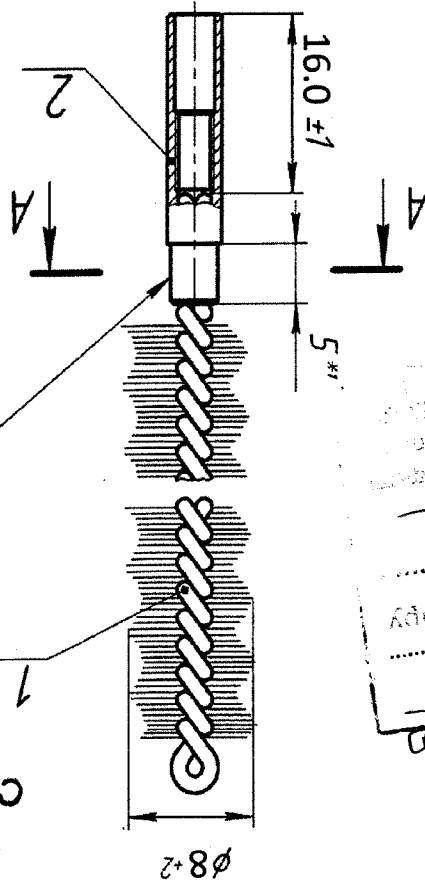

हस्ताक्षर  
Jr. Works Manager  
16/10/23  
as correct copy  
on 16/10/23

SAF CONFIDENTIAL  
COPY NO. 1

D.A. NO.

DRG. NO. SK-6605 TE

SAF CONFIDENTIAL  
COPY No. 1

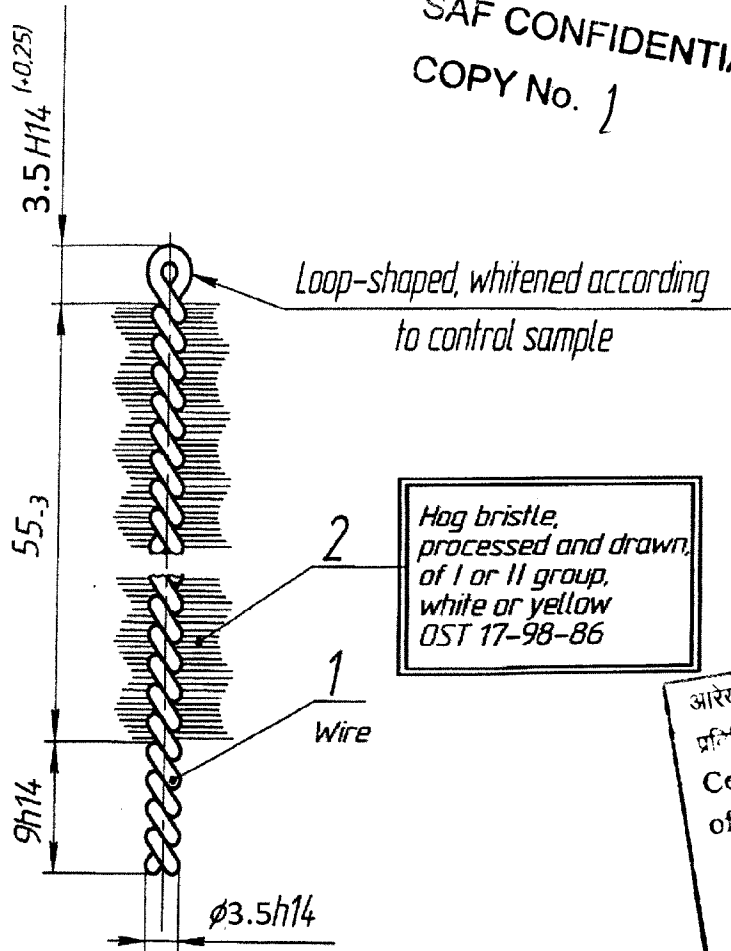

Handwritten: HOS/...  
 आरेखण की सही प्रमाणित प्रतिलिपि प्रमाणित  
 Certified as correct copy of drg. on... 16/10/23...  
 ना. कार्यालय प्रबन्धक  
 Jr. Works Manager  
 डी.डी.ओ.  
 100

1 Appearance of brush regarding number and evenness of bristles on helix is according to control sample.

2 Coating is Chem. Oxid. with oiling prior to assembling with preliminary chemical milling.

Weight 2.7 g

**7.62x39mm AR-SAF  
BRUSH  
SUB-ASSY. DRAWING**

DRAWN	TRACED	CHKD.
S P SONI		
DATE	11.10.23	
APPROVED		
HOS/DDO		

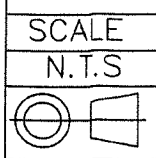

SMALL ARMS FACTORY  
KANPUR

DRG. NO.  
**SK-6606 TE**

✓ Rz40 (✓)

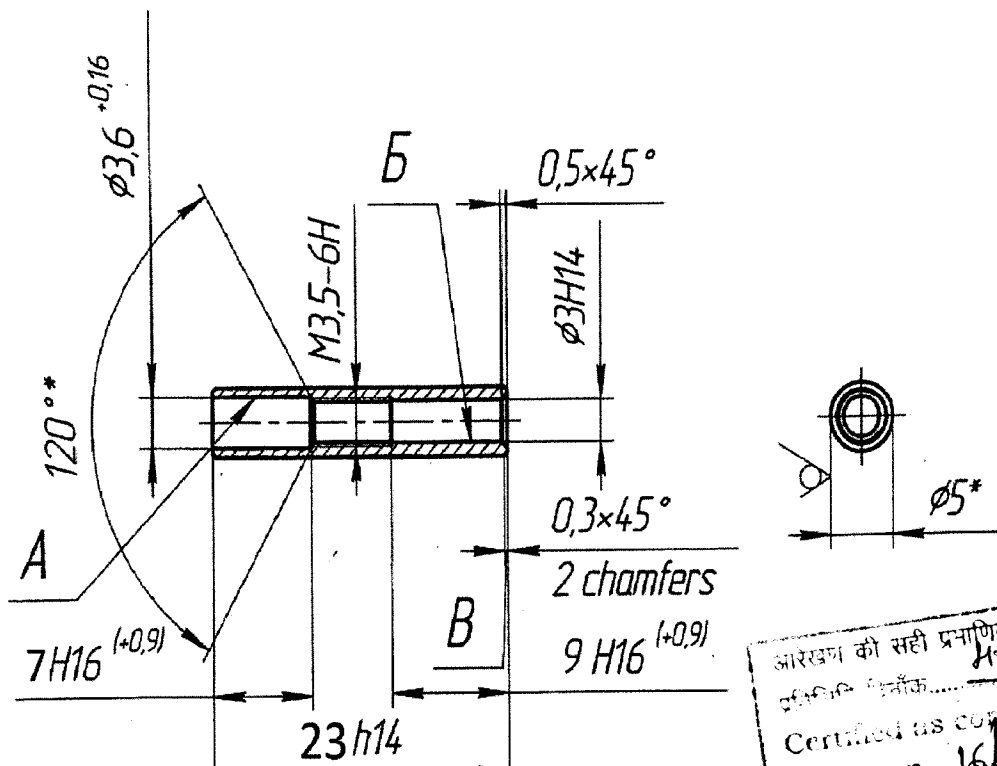

आरेखण की सही प्रमाणित  
 प्रतिलिपि प्रमाणित  
 Certified as correct copy  
 of drg. on... 16/10/23  
 क. मन्मथ लाल प्रसाद  
 Jr. Works Manager  
 डी.डी.ओ.  
 220

- 1 \* Reference dimensions.
- 2 Radial rounding R 0,2 ... 0,5 mm according to control sample is allowed instead of chamfers B.
- 3 On surface A and B circular tap traces are allowed.
- 4 Coating is Chem. Phos. chr. with oiling.

MATL. - Round bar 5-h11 GOST 7417-75  
 15-B-H GOST 1051-73  
 Weight 1,8 g

**7.62x39mm AR-SAF**  
*Sleeve*

DRAWN	TRACED	CHKD.
S P SONI		
DATE	11.10.23	
APPROVED		
HOS/DDO		

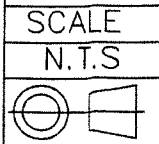

SMALL ARMS FACTORY  
KANPUR

DRG. NO.

**SK-6607 TE**

SAF CONFIDENTIAL  
COPY No. 1

A (5:1)

√ RZ40 (✓)

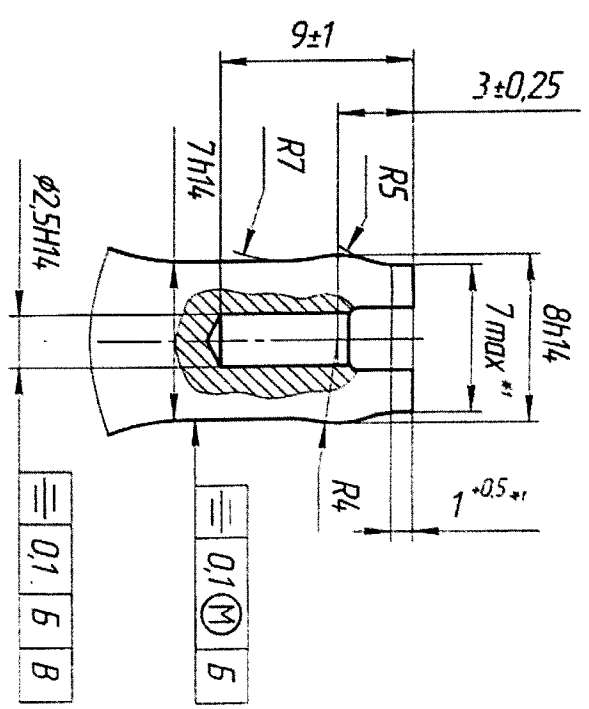
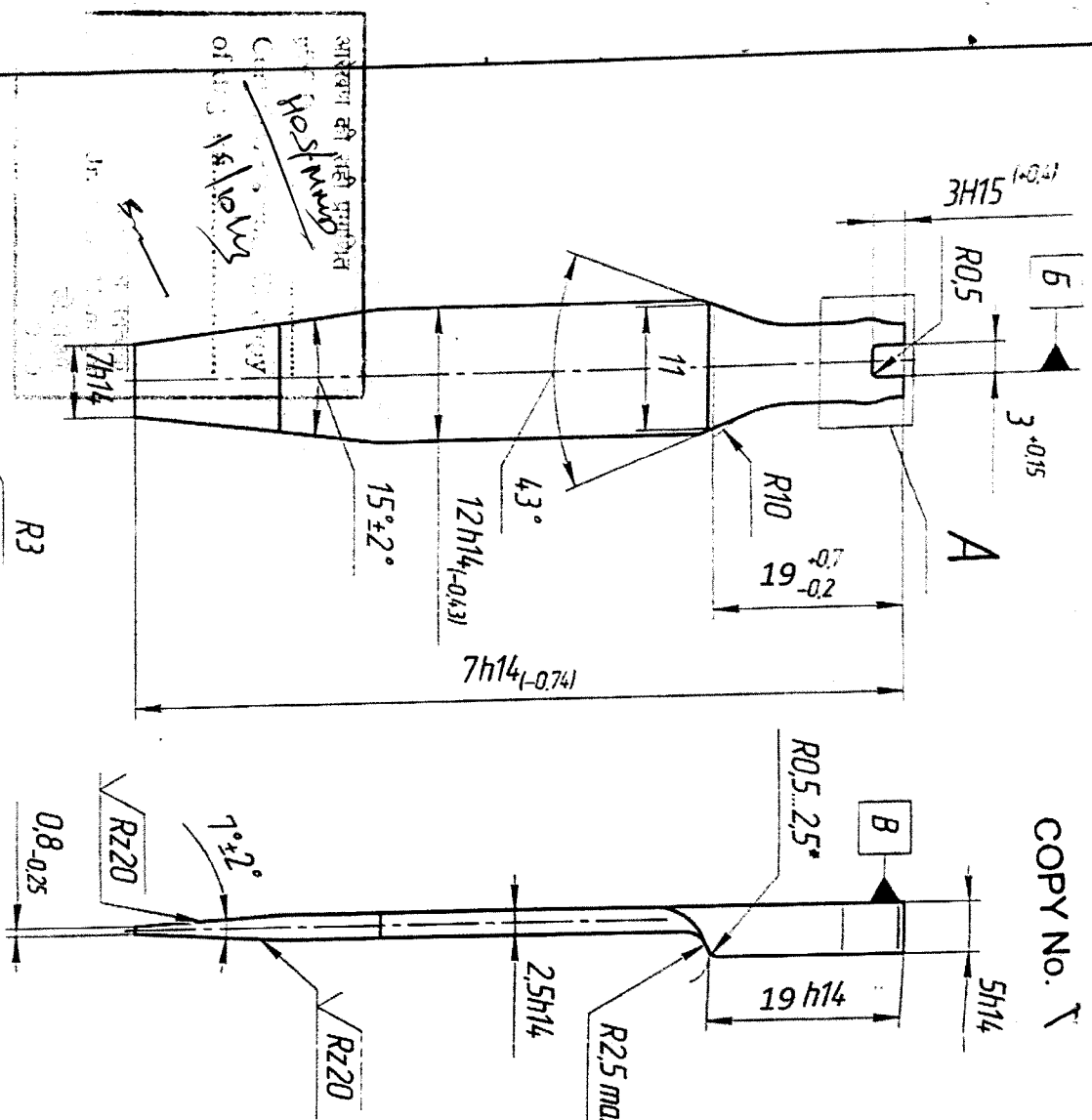

- 1 38...45 HRC.
- 2 \* Dimensions to be ensured by tool.
- 3 \*\* Dimensions for gauge contouring.
- 4 Unspecified tolerances according to 6N45-1 (GTY/E2).
- 5 Appearance of surfaces after stamping is according to control sample.
- 6 Coating is Chem. Phos. chr./impreg. with 6P-4 glue GOST 12172-2016 with nigrosine of grade A GOST 9307-78.

संख्या की संज्ञा  
Hosknum  
of 14/10/13

MATL. - Bar 9-F-H11-H-50  
GOST 14955-77

SCALE N T S		SMALL ARMS FACTORY KANPUR		DRG. NO. SK-6608 TE	
7.62x39mm AR-SAF Screwdriver		Weight: 15.8g		SHT. 1 of 1	
DRAWN		SEEN BY		CHECKED	
DATE 12/10/2023		APPROVED		HOS/DNO	



SAF CONFIDENTIAL

COPY No. 1

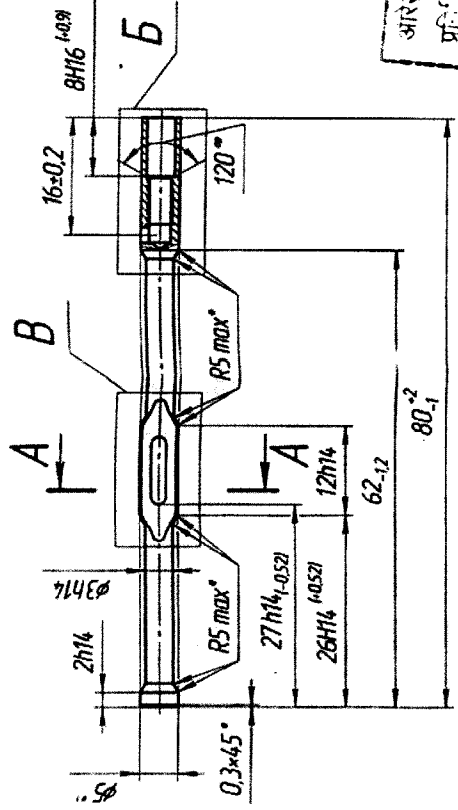

B (5:1)

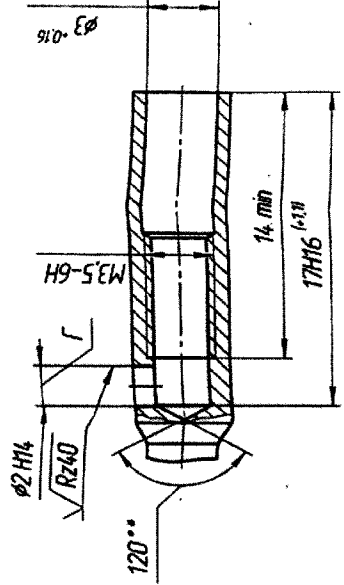

अखण्ड की सही प्रमाणित प्रतिलिपि का प्रयोग करें।  
 Certified copy of drg. on 16.11.09  
 प्रमाणित प्रतिलिपि का प्रयोग करें।  
 16.11.09

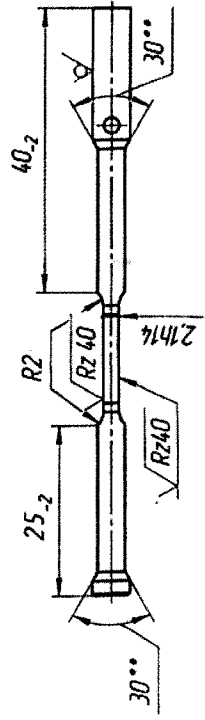

B

A-A (5:1)

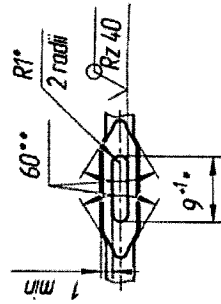
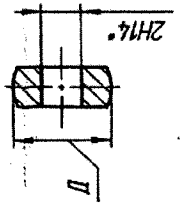

- 1 34.0..38.5 HRC.
- 2 \*Dimensions to be ensured by tool.
- 3 \*\*Reference dimensions.
- 4 Unspecified tolerances according to 6145-1.0019/E2.
- 5 Hole  $\Gamma$  is allowed to be randomly located on outer surface.
- 6 It is allowed to increase diameter  $\Pi$  up to 5.2 mm after slot punching.
- 7 Appearance according to control sample.
- 8 Cooling is Chem. Phos. chr. with oiling.

7.62x39mm AR-SAF

Pull-through

SCALE N.T.S.

SMALL ARMS FACTORY

MATL.- Round bar 5-HI GOST 7417-75 35-B-H GOST 1051-73

Weight:	4.8 g	
DRAWN	BY	CHECKED
DATE	12/07/09	APPROVED
HCS/000		SK-6609 TE

$\sqrt{Rz\ 20\ (\checkmark)}$

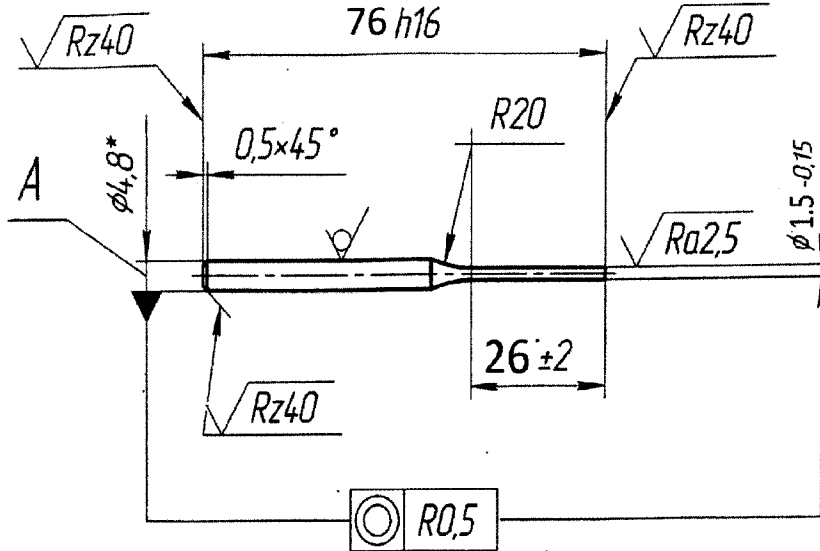

- 1 48,5...53 HRC.
- 2 \*Reference dimensions.
- 3 It is allowed to increase dimension A up to  $\phi 4,9$  mm.
- 4 Unspecified tolerances according to 6П45-1.CDTY/E2.
- 5 Coating is Chem. Phos. chr /impreg with БФ-4 glue GOST 12172-2016 with nigrosine of grade A GOST 9307-78.

आरेख की सही प्रमाणित  
 Copy and its correct copy  
 of drg. on... 16/10/23  
 न. पंजाबसाली प्रबन्धक  
 Jr. Work Manager  
 डी.डी.ओ.

MATL. - Round bar  $\frac{4,8-h11\ GOST\ 7417-75}{55-B-H\ GOST\ 1051-73}$

Weight 8 g

**7.62x39mm AR-SAF**  
 Drift

DRAWN TRACED CHKD.

S.P SONI

DATE 11.10.23

APPROVED

HOS/DDO

SCALE  
 N.T.S

**SMALL ARMS FACTORY**  
**KANPUR**

DRG.NO.

**SK-6610 TE**

