

ISOMETRIC VIEW

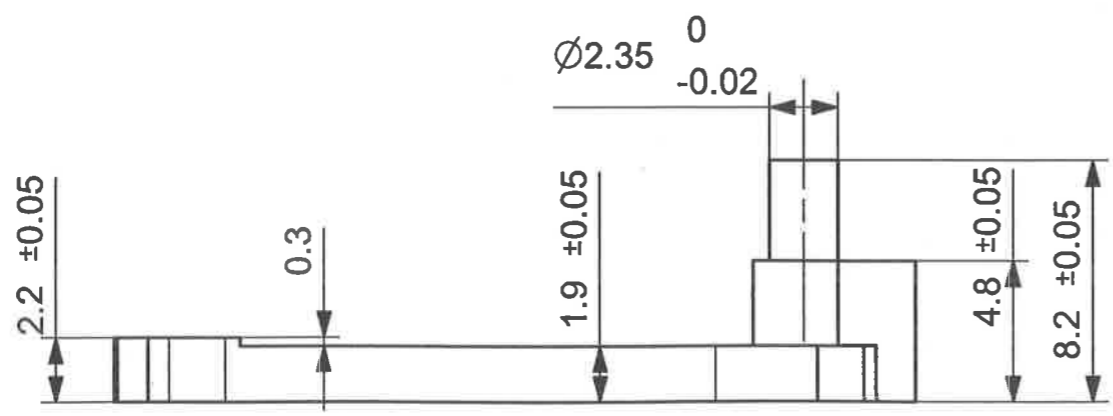
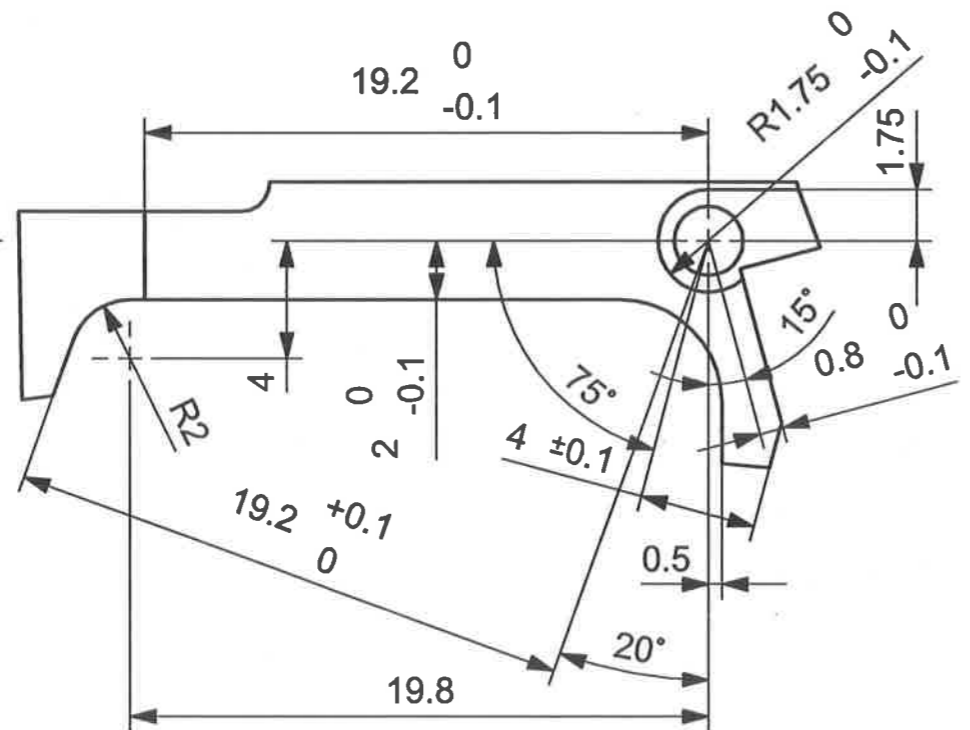

MATERIAL:- STEEL BS970 Pt.1:1983 Gd.070M55 OR En-9

HEAT TREATMENT:- HARDENED & TEMPERED TO 500 - 550 H.V.
WITH CASE DEPTH 0.13 TO 0.26 mm.

PROTECTIVE FINISH:-PHOSPHATED TO SPECN. J.S.S.-0465-01:1988
CLASS II (ACCELERATED) OIL FINISH.

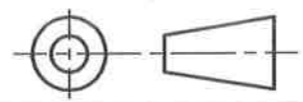
REVOLVER.32 (7.65 mm) SIDE SWING PAWL SCALE 4 : 1 	DESIGNED BY	A.S.RANA
	CHECKED BY	JWM/DDO
	APPROVED BY	WM/DDO
	DATE	03.05.2019
SMALL ARMS FACTORY KANPUR		DRAWING NO. RV-07/9 SW SHEET 1 OF 1

DIMENSIONS ARE IN MM.