

REVISION - I

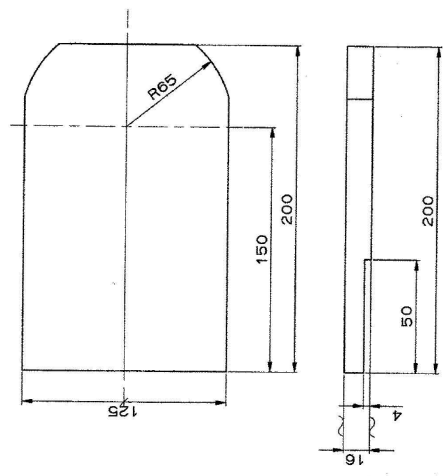

ALTERNATE MATERIAL :- EN-8 OR
080M40 BS970 PART-1 1983

DW-1108-4402-1	SUPPORT PLATE	40CB	IS:9517	1	1:2
DRAWING NO.	NOMENCLATURE	MATERIAL	NO.	OFF	SCALE

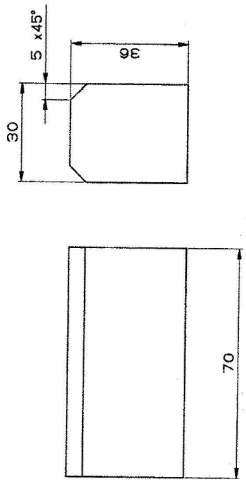

ALTERNATE MATERIAL :- EN-8 OR
080M40 BS-570 PART-1 1983

DW-1108-4403-1	SUPPORT LEG	40CB	IS:9517	2	1:1
DRAWING NO.	NOMENCLATURE	MATERIAL	NO.	OFF	SCALE

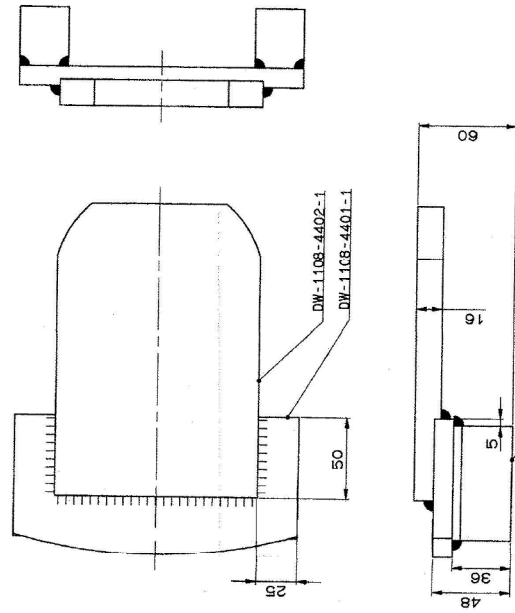

STRESSES TO BE BELIEVED AFTER WELDING

E-WELDED

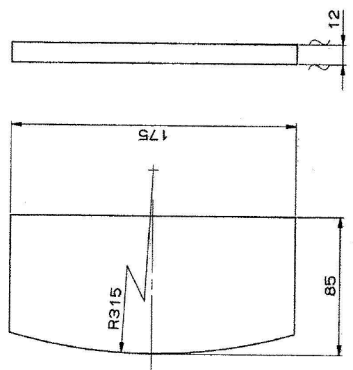

ALTERNATE MATERIAL :- EN-8 OR
080M40 BS:970 PART-1 1983

DW-1108-4401-1	BASE PLATE	40CB	IS:9517	1	1:2
DRAWING NO.	NOMENCLATURE	MATERIAL	NO.	OFF	SCALE

No. OFF	DESCRIPTION	PART No.	MATERIAL	STANDARD	DIMENSIONS	REMARKS
1	SUPPORT BRACKET-111					

GENERAL TOLERANCE	LINEAR DIMENSIONS	ANGULAR DIMENSION	No. OFF	FIG. No. OF ASSOCIATED PART	INDEX	ALTERATION	DATE	BY	CHKD	APPROVED	DATE
F8	0.1-1	±30'					2006				
F7	1.0-10	±30'									
F6	10-100	±30'									
F5	100-1000	±30'									
F4	1000-10000	±30'									
F3	10000-100000	±30'									
F2	100000-1000000	±30'									
F1	1000000-10000000	±30'									

SCALE	1:2
CHECKED	11/7
APPROVED	11/7
DATE	2006
BY	
CHKD	
APPROVED	
DATE	

SUPPORT BRACKET-111	
ELEVATING HAND DRIVE ASSY	
LR-MR LAUNCHER	
KAVACH MOD-11	
MACHINE TOOL PROTOTYPE FACTORY,	
AMBERNATH	
DRAWING No.	DW-1108-4400-42

THE COPYRIGHT OF THESE DRAWINGS AND ATTACHMENTS TO THE HOI JAN SHOULD NOT BE LOANED, REPRODUCED, COPIED, OR IN ANY MANNER CONTAINED HEREIN MADE AVAILABLE TO UNAUTHORIZED PERSONS WITHOUT THE WRITTEN PERMISSION OF THE DIRECTOR OF ORDNANCE FACTORIES.

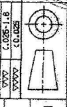

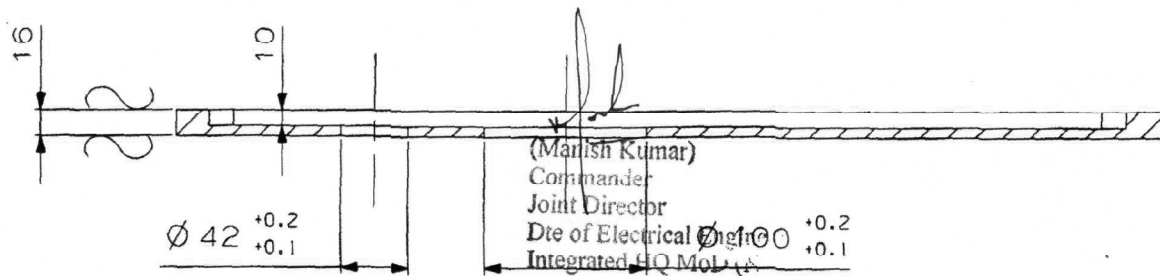
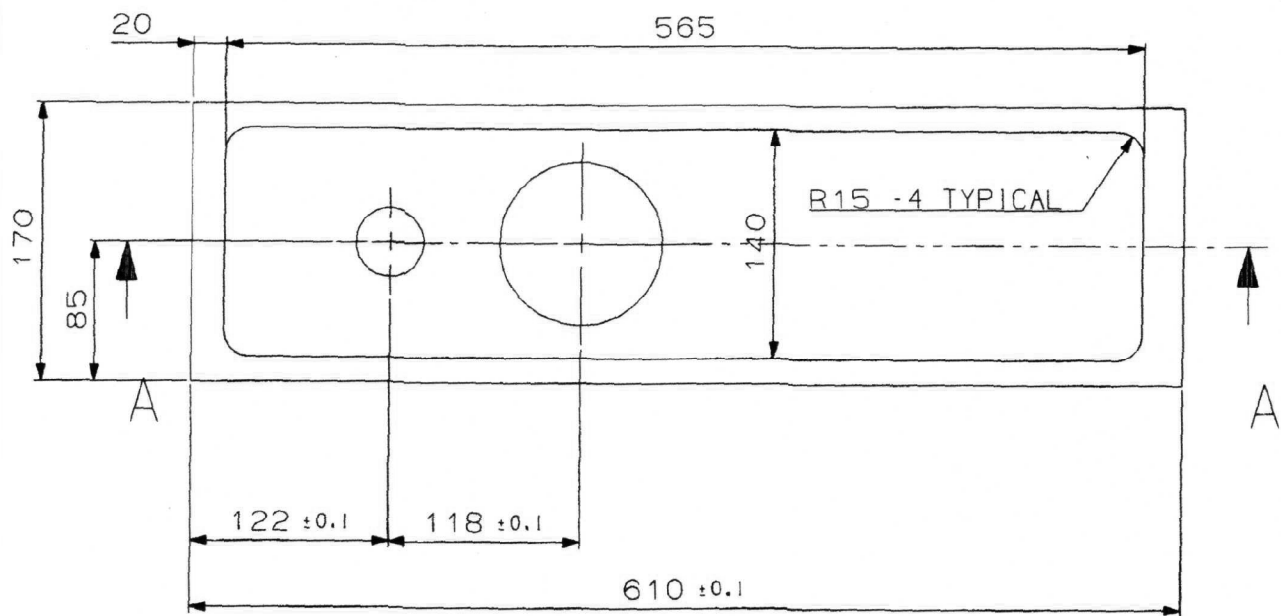

(Manish Kumar)
 Commander
 Joint Director
 Dte of Electrical Engineering
 Integrated HQ Mod-11
 New Delhi-110011

SECTION A-A



APPROVED

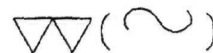

		1	TOP PLATE	40C8, IS:5517-1993				
		NO. OFF	DESCRIPTION	PART NO.	MATERIAL & STD.	DIMENSION	REMARKS	
		GENERAL TOLERANCE						
		LINEAR DIMENSIONS						
		0-6	±0.1					
		6-30	±0.2					
		30-120	±0.3					
		120-315	±0.5					
		315-1000	±0.8					
		1000-2000	±1.2					
		ANGULAR DIMENSION						
		1-10	±1°					
		10-50	±30'					
		50-100	±20'					
		>100	±10'					
		VALUE IN "µm"						
		~	>25					
		▽	B-25					
		▽▽	1.6-B					
		▽▽▽	0.025-1.6					
		▽▽▽▽	< 0.025					
		TOP PLATE FOR HOUSING-IV WORM & WORM WHEEL ASSY-1 LRMR LAUNCHER KAVACH MOD-11				SCALE	DRAWN	DATE
						1:1	CHECKED	31-05-01
							APPROVED	DHR
						REPLACED BY		
						REPLACED FOR		
						DRAWING NO.		
						DW-1108-4631-1		
NOMINAL SIZE & FIT	DEVIATION			MACHINE TOOL PROTOTYPE FACTORY AMBERNATH		Design Office		

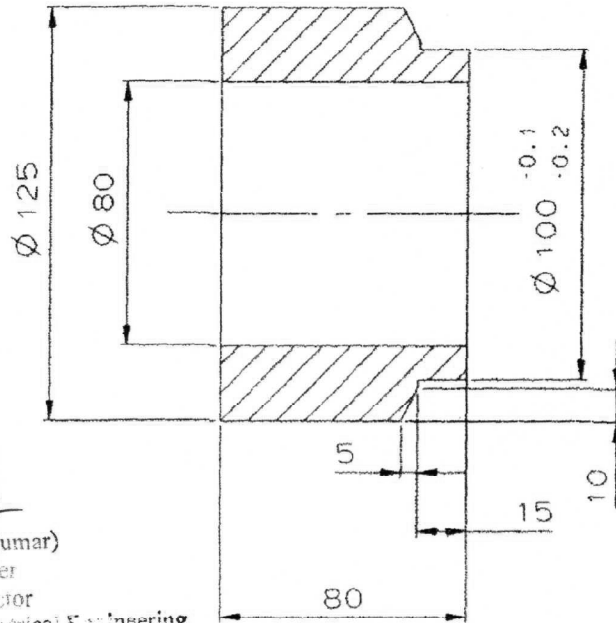
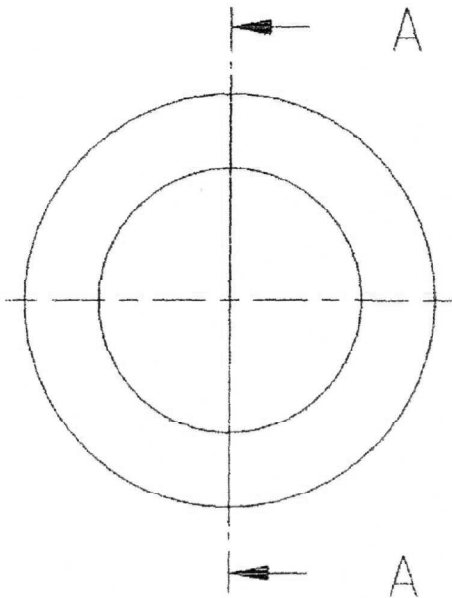

(Manish Kumar)
 Commander
 Joint Director
 Dte of Electrical Engineering
 Integrated HQ. Mod. (Navy)
 New Delhi-110011

SECTION A - A

APPROVED



		1	BUSH	40C8,IS:5517-1993			
	NO. OFF	DESCRIPTION		PART NO.	MATERIAL & STD.	DIMENSION	REMARKS
GENERAL TOLERANCE							
LINEAR DIMENSIONS							
	0-6	±0.1					
	6-30	±0.2					
	30-120	±0.3					
	120-315	±0.5					
	315-1000	±0.8					
	1000-2000	±1.2					
ANGULAR DIMENSION		NO. OFF	ORG. NO OF ASSOCIATED PART	INDEX	ALTERATION	DATE	NAME
	1-10	±1°					
	10-50	±30"					
	50-100	±20"					
	>100	±10"					
VALUE IN "um"							
	~	>25					
	∇	8-25					
	∇∇	1.6-8					
	∇∇∇	0.025-1.6					
	∇∇∇∇	< 0.025					
NOMINAL SIZE & FIT	DEVIATION	MACHINE TOOL PROTOTYPE FACTORY AMBERNATH			Design Office	REPLACED BY	
					REPLACED FOR	DRAWING NO.	DW-1108-4632-1
					SCALE	DRAWN	02-08-18 VIJAY
					1:1	CHECKED	" h
						APPROVED	