

RFL SK 8877

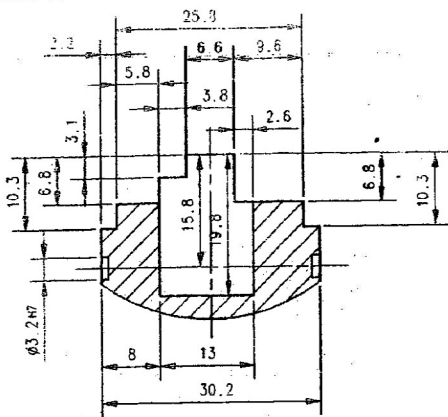

SECTION-AA

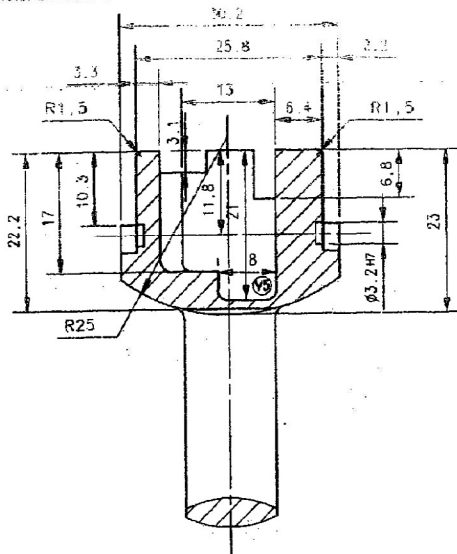

SECTION-BB

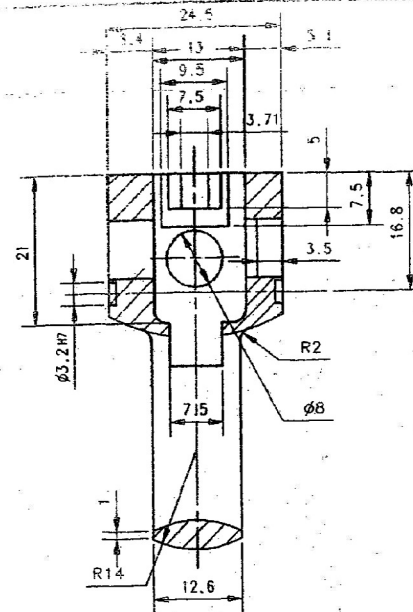

SECTION-CC

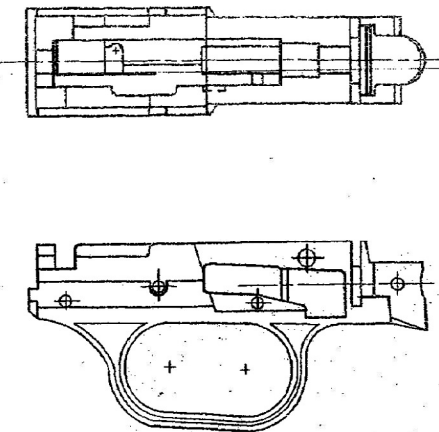

SCALE:- 1:1

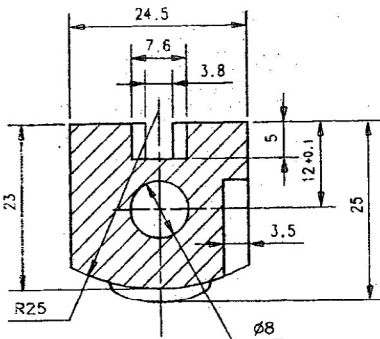

SECTION-DD

SECTION-FF

UNSPECIFIED TOLERANCES AS PER IS:2102

ABOVE	-	6	30	120	315
UP TO AND INCLUDING	6	30	120	315	1000
FINE	+0.05	+0.1	+0.15	+0.2	+0.3

TOL. ON FIT.	TOL. ON MM.
3.2H7	+0.012 +0.000
3.5H7	+0.012 +0.000
4.75H7	+0.012 +0.000
7H11	+0.030 -0.000
3.5C11	+0.145 +0.070

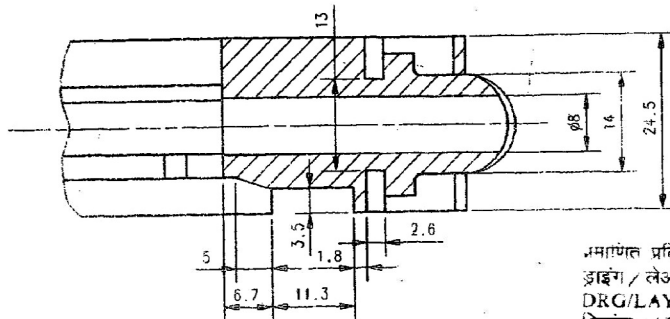
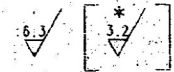

SECTION-GG

NOTE: ALL HOLES DEPTH TO BE 2mm FROM SURFACE TO BE MAINTAINED

NOTE:- MANUFACTURER'S INITIAL/CODE NO. YEAR OF MANUFACTURE SHOULD BE ENGRAVED AT SUITABLE PLACE.

- NOTE:- 1. UNSPECIFIED RADII SHALL BE NOT MORE THAN 1 MM.
 2. ALL SHARP EDGES TO BE SMOOTHLY ROUNDED OFF
 *3. SECTION AA, BB, CC, DD & GG WERE GIVEN WITH REFERENCE TO SHEET 1 OF 2.
 4. ONE SAMPLE TO BE TRIED BEFORE PLACING BULK ORDER.

प्रमाणित प्रति / CERTIFIED COPY OF
 ड्राइंग / लेआउट / गेज शिड्यूल Ho / mm
 DRG / LAYOUT / GAUGE SCHE
 दिनांक / AT THIS DATE 02.02.18
 सी डी डी / CDD
 राइफल फैक्टरी, ईशापुर
 RIFLE FACTORY, ISHAPUR

PROVISIONAL

MATL:- 1. IS: 617, 1975, Grd. 4420 'R' CONDITION OR Grd. 24345 IS: 734-75 'WP' CONDITION.	2013	NAME	DATE
ORDNANCE FACTORY BOARD RIFLE FACTORY ISHAPUR	DGN		
	DRN	M M K	14-02-15
SCALE	CKD		
	APPD	J. J. G. Q.	
TRIGGER HOUSING DIE CASTING 12 BORE MODIFIED PUMP ACTION GUN	DRG. NO.	RFL SK 8877	