

DRAWING NUMBER

175.91.187

SHEET No 1 OF 1

**EXPLANATORY NOTE :-**

5. REFERENCE MATERIAL QUOTED :- ALUMINIUM ALLOY SHEET 2 mm THICK ANNEALED (M) WITH TECHNOLOGICAL CLADDING (B) WITH NORMAL SURFACE FINISH TO GOST 21631 - 76 MANUFACTURED FROM GRADE AMГ 6 TO GOST 4784 - 74.

(a) CHEMICAL COMPOSITION :-

ALLOY GRADE	ALLOYING CONSTITUENTS					IMPURITIES (MAX)				OTHER IMPURITIES	
	Al	Mg	Mn	Ti	Be	Fe	Si	Cu	Zn	EACH INDIVIDUALLY	TOTAL
AMГ 6	BASE - CONSTITUENT	5.8 - 6.8	0.5 - 0.8	0.02 - 0.10	0.0002 - 0.0005	0.4	0.4	0.1	0.2	0.05	0.1

(b) MECHANICAL PROPERTIES AS PER GOST 21631 - 76.

ALLOY GRADE	MATERIAL CONDITION OF SHEET	TENSILE STRENGTH Kgf / mm <sup>2</sup>	YIELD POINT Kgf / mm <sup>2</sup>	ELONGATION %
AMГ 6	ANNEALED	31.0	15.0	15.0

1. MANUFACTURE FROM SHEETS AMГ 6M (UNCOATED) AND AMГ 6YM GOST 21631 - 76 IS ALLOWED.
2. TOOL MARKS AND IMPRINTS ARE ALLOWED ON THE SURFACE OF COMPONENT.
3. OTHER REQUIREMENTS AS PER 432. U6 - 1.
4. \* DIMENSION FOR REFERENCE.

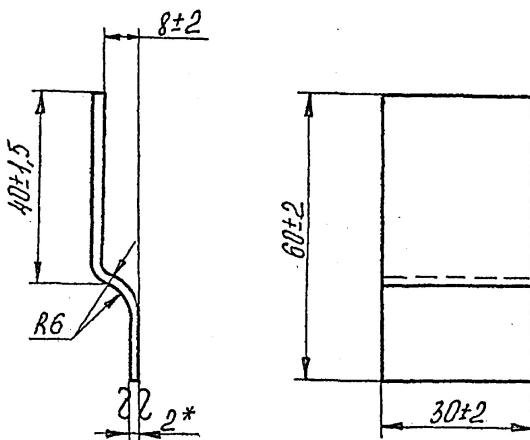

COMMON TO T-90 & BLT  
DRG RE - INDIANISED BASED ON RUSSIAN ORIGINAL ISSUE - 4  
17-05-06  
B. JAYAVELUJI, JTOID

⊗  
4A 188.91.008cbCb  
188.91.008cb-1Cb

⊗ ALT. MATL: GRADE 54300 TO IS: 737-86

PILOT SAMPLE SHOULD BE APPROVED BY A H S P BEFORE BULK PRODUCTION.

EST. WT. (Kg) TO BE STAMPED OR MARKED WHERE INDICATED THUS # ( LETTERS)  
0.01

ALL SHARP EDGES AND CORNERS TO BE REMOVED UNLESS OTHERWISE STATED MACHINED CORNERS TO HAVE R OUTSIDE R INSIDE EQUIVALENT CHAMFERS ARE PERMISSIBLE.

			DRN	Sd/=	MATERIAL :-	USED ON :-
			CHD	Sd/=	SHEET AMГ 65M - 2	172.91.252cbCb
			APPD	Sd/=	GOST 21631 - 76	
			DATE	27 - 03 - 86	CONTROLLERATE OF QUALITY ASSURANCE (HEAVY VEHICLES) AVADI	
			SCALE:- 1 : 1			
			DIMENSIONS IN mm			
			TOLERANCE ON DIMNS UNLESS OTHERWISE STATED IS : 2102 - 69			
			TITLE :-			
			CLAMP			
	4B	16.5.06	AUTHY Lt.No.80001/CQA(HV)/GEN/A Dt.13.1.06			
	4A	2.8.04	N OF A No.CQA(HV)/T90/91/001			
	ISSUE	DATE	NATURE OF AMENDMENTS			
			ALL THREADS TO CONFORM TO IS : 4218 Pt. IV			
			D S CAT NUMBER			DRAWING NUMBER
						175.91.187

F-172  
SIZE A3