

41989, 4490307006

2

THIS DOCUMENT AND THE INFORMATION CONTAINED IN IT ARE PROPRIETARY AND CONFIDENTIAL TO ODT. NO PERSON OR ENTITY IS ALLOWED TO COPY, REPRINT, REPRODUCE OR PUBLISH ANY PART OF THIS DOCUMENT, NOR DISCLOSE ITS CONTENTS TO OTHERS, NOR MAKE ANY USE OF IT, NOR ALLOW OR ASSIST OTHERS TO MAKE ANY USE OF IT UNLESS BY THE PRIOR WRITTEN EXPRESS AUTHORIZATION OF ODT AND THEN ONLY TO THE EXTENT AUTHORIZED. COPYRIGHT-ODT.

NOTES:

1. INTERPRET THIS DRAWING IAW ASME Y14.100M.
2. MATERIAL: CRES BAR TYPE 17-4PH PER AMS 5643, (EQUIVALENT STEEL IS PERMITTED AFTER ELBIT APPROVAL).
3. HEAT TREATMENT TO H1150 PER MIL-H-6875 CLASS D.
4. DEBUR AND REMOVE SHARP EDGES APPROX. 0.3X45°.
5. GENERAL TOLERANCES ACCORDING TO ISO 2768-m.
6. PASSIVATION TREATMENT PER AMS-2700 METHOD 1 TYPE 8.
7. BAKE PART AFTER PLATING WITHIN 3 HOURS PER AMS-2759/9 TABLE 1 FOR 3 HOURS MINIMUM AT 191°C.
8. QUALITY ASSURANCE PROVISIONS: 8.1 QUALITY ASSURANCE PROVISIONS FOR THIS ITEM PER RDMQD00012P.
9. PACKAGING AND PACKING: THE FINISHED PART SHALL BE PRESERVED AND PACKAGED IN ACCORDANCE WITH COMMERCIAL PRACTICE.
10. IDENTIFY PER MIL-STD-130 PARA 4.1.B. BY LABELING ITS CONTAINER WITH THE PART NUMBER, CHARACTER 1.25 MM HIGH.

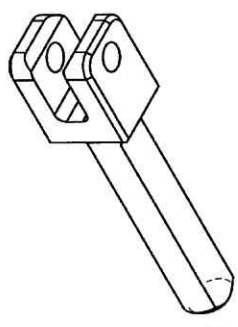

26.11.2020
 Design & Drawing Office
 Ordnance Factory
 Tiruchirappalli

DWG NO 065038A-00	
SHEET REV RECORD	
ALL SHEETS ARE THE SAME REVISION	

REV	ECO	DESCRIPTION	DATE	APVD
01		Freeze	27-Jun-12	
02		Freeze	27-Nov-12	
03		Restricted	30-Dec-13	
		T00064 Identical To Previous	Released	09-Apr-18
				L. Goldstein

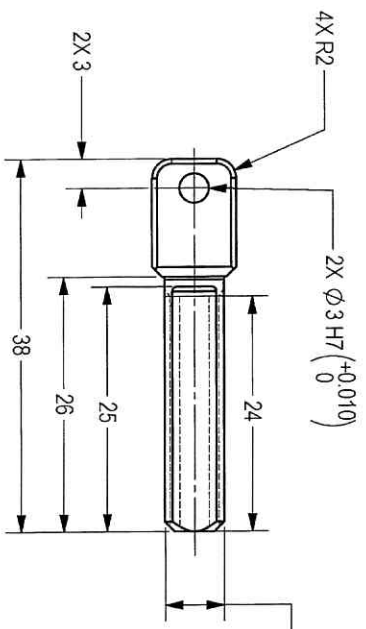
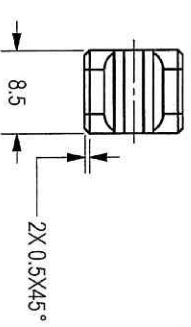
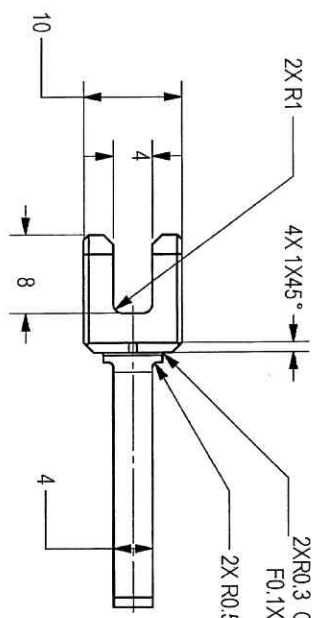

SEE ATTACHED MEDIA

(WEIGHT APPROX.: 0.011 Kg.)

UNLESS OTHERWISE SPECIFIED DIMENSIONS ARE IN MM PER ASME Y14.5M-1994		DRAWN		SIGNATURE		DATE	
TOLERANCES		CHECKED					
LINEAR SEE NOTE 5		ANGULAR SEE NOTE 5		HOS/DO		OFFICER/PROD	
1st ANGLE PROJECTION		OFFICER/OC		OFFICER/DO		OFFICER/DO	
SURFACE TEXTURE IN Micro M		PROJECT OFFICER		PLM Control			
TITLE		ORDNANCE FACTORY		TIRUCHIRAPPALLI		FOR: PEDESTAL ASSY	
SCREW, SPRING INTERFACE		OF: 12.7MM SRCG		CAGE CODE		DWG NO	
SIZE B		SCALE 2:1		AUTOMATED DRAWING (SW)		SHEET 1 OF 1	
2291A		065038A-00					

2

1