

FOR EXPLANATION OF DIMENSIONING ETC. SEE ARDE NOTE SHEET No.1(LATEST ISSUE)

NOTE :-
 YEAR OF MANUFACTURE & LOT NUMBER TO BE SCREEN PRINTED IN BLACK COLOUR TO THE POSITION SHOWN THUS ϕ † IN 3mm. LETTERS & FIGURES.

MANUFACTURER'S CODE MARK TO BE MOULDED IN POSITION MARKED * IN 3mm. SIZE.

DRAFT ANGLE TO BE $1/2$ TO 1° WHERE REQUIRED. MAX. RAD. ALLOWED IN CORNERS ± 0.25 UNLESS OTHERWISE STATED.

GENERAL TOL. ± 0.13 EXCEPT OTHERWISE STATED. TOL. ON CENTRES ± 0.13 UNLESS OTHERWISE STATED.

FOR COLOUR SHADE ONLY
 COLOUR SHADE SHOULD CONFORM TO No. 489. LEAF. BROWN AS SHOWN IN SPECIFICATION IS:5-1994

FINISH :-
 CROCODILE LEATHER FINISH ON SURFACES MARKED THUS \oplus

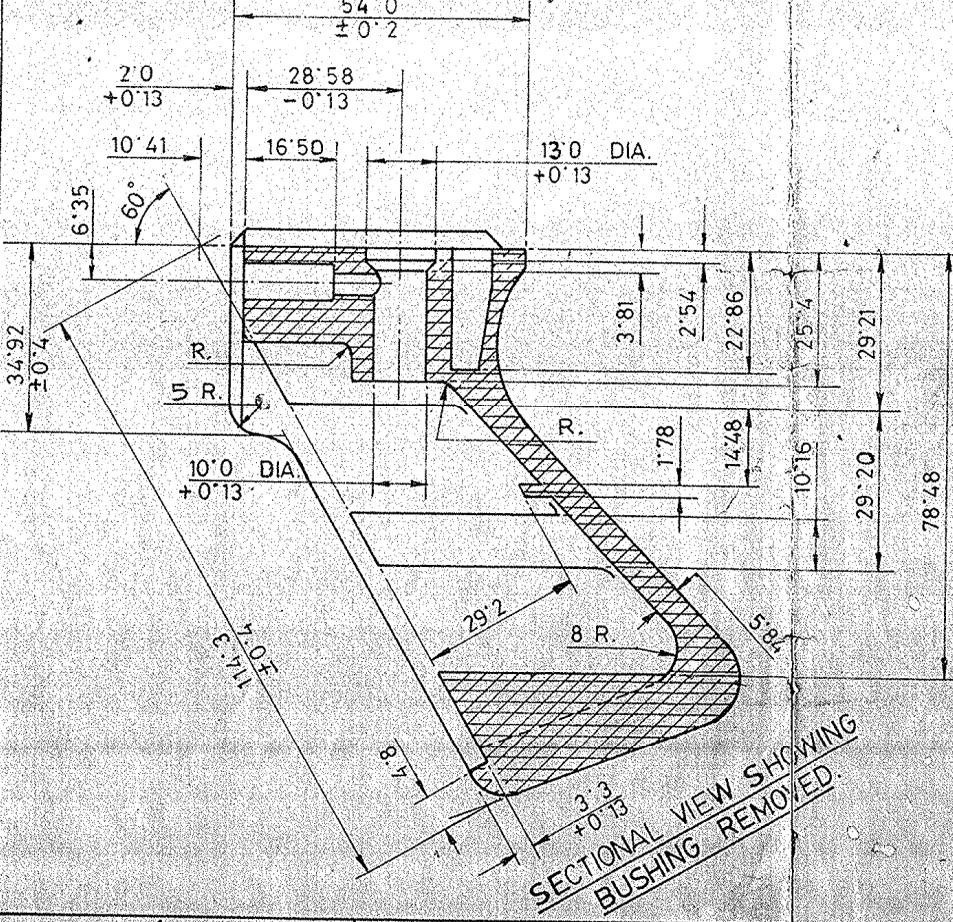
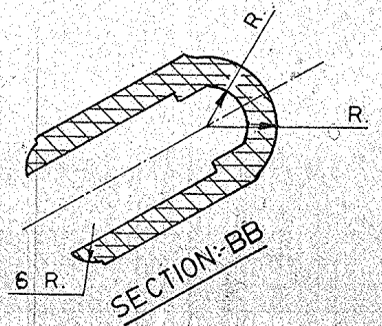
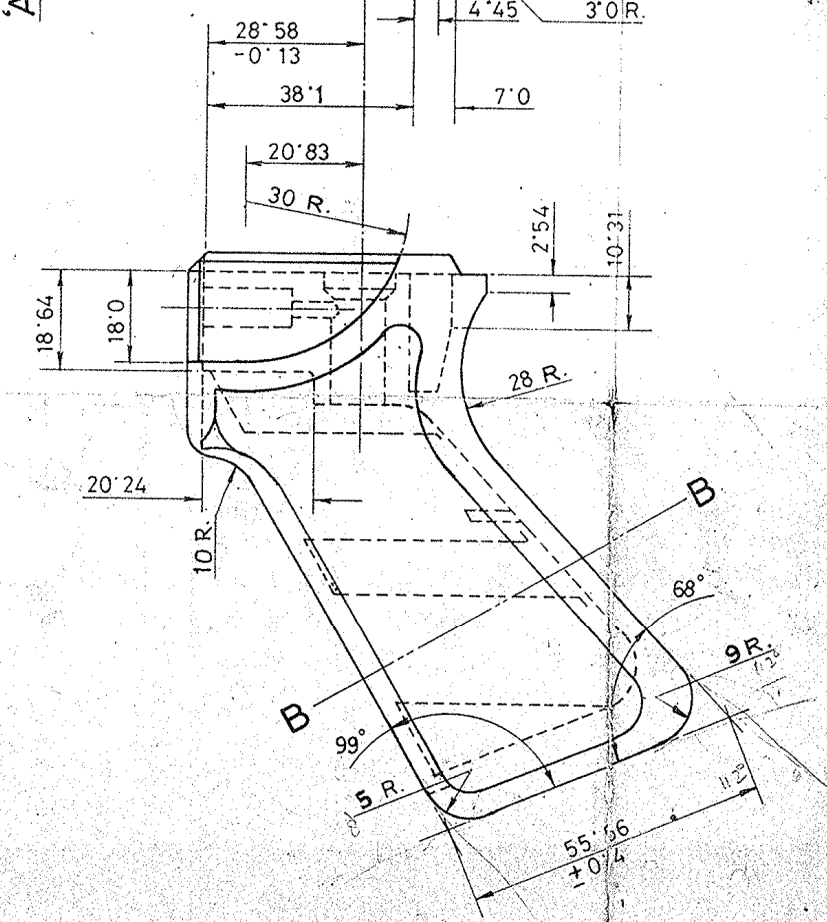
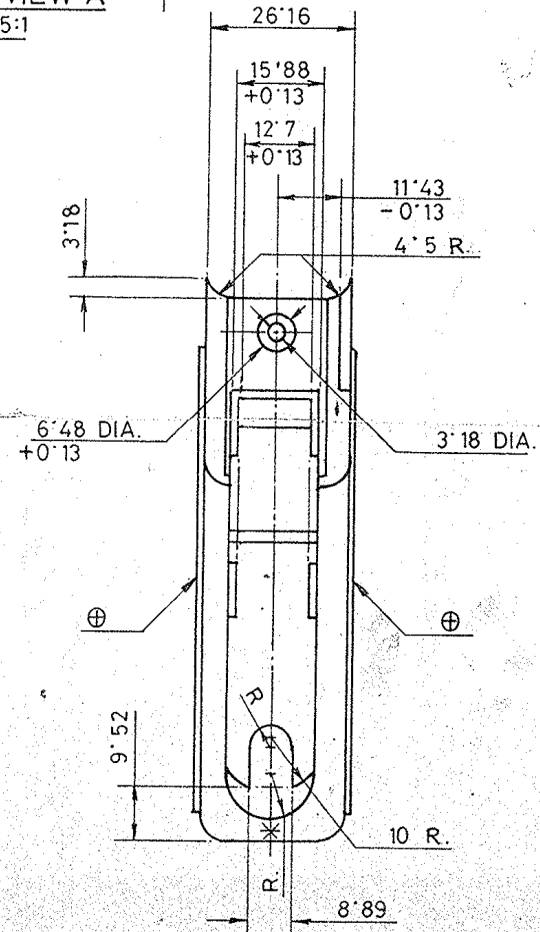
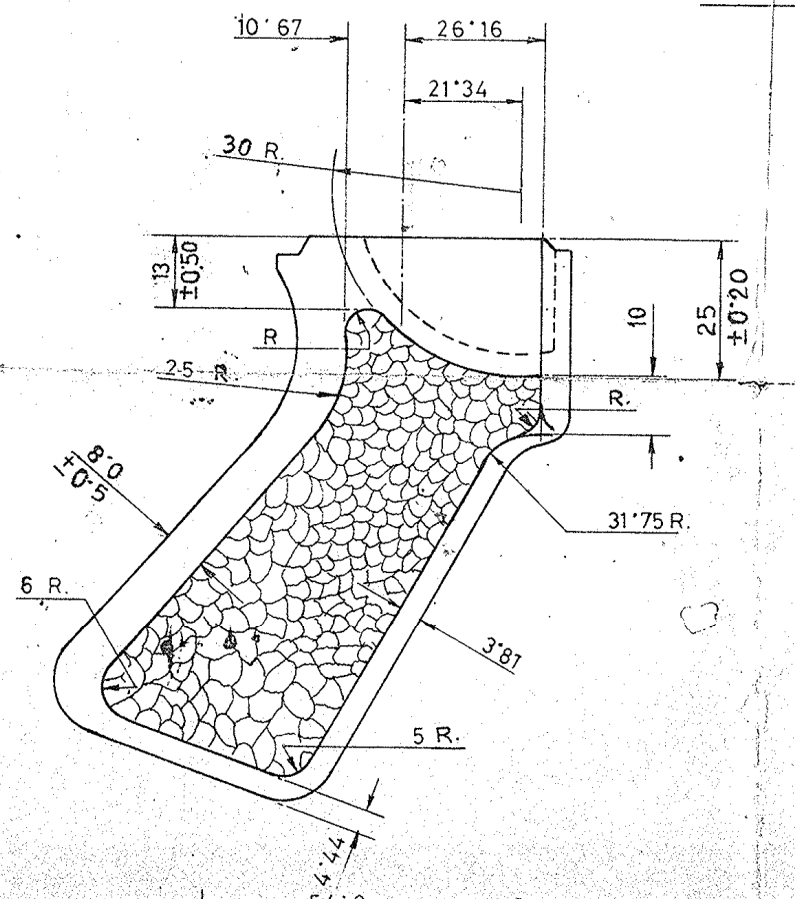
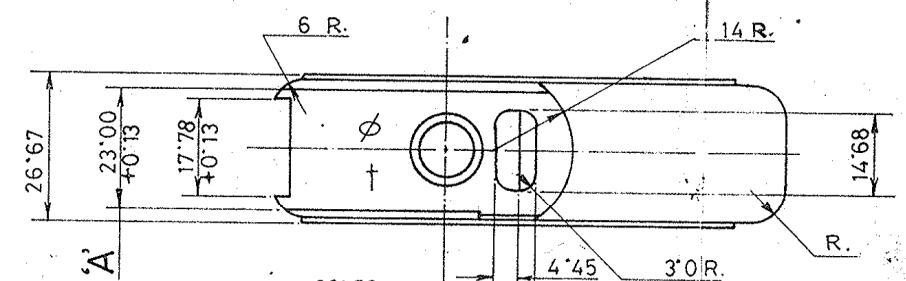
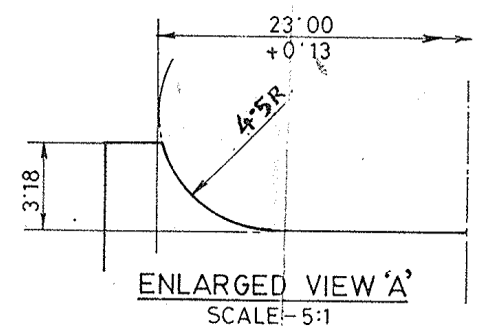

CERTIFIED COPY OF THE STORE
 D.O. DATE ENG. SCHEDULE/
 DRAWING SPECIFICATION
 CCA (SA) CONTROL
 DATE: 28/10/98 C/D

DRN	CHD	TRD	S. K. P	COMP.	ASSY.	1005-004030
SCALE: 1:1		MFG/INSP. INSTRUCTIONS		EST. MASS		
13-8-98	24158-SA	MATL. & SPECN. OF COLOUR SHADE AMENDED		APPROVED	DT. 19.7.71	
5-6-96	23352-SA	PROFORMA CHANGED, MATERIAL AMENDED, DRAWING REVISED, NEGATIVE RETRACED AND DRAWING RE-SEALED		NEG. RETRACED.		
PREVIOUS D.C. Nos. 10945-SA 11015-SA 11068-SA 11230-SA 11270-SA 14602-SA 15466-SA 15590-SA 15832-SA 15911-SA 16747-SA 17383-SA 18039-SA 19394-SA 19905-SA 20596-SA 20995-SA 21115-SA & 22420-SA		DATE AUTHY		BRIEF RECORD	ZONE	1/C, D.O. G.D.
SEALED		D.C. No. 10945-SA. DT. 26.7.71		SIGN.		
NOMENCLATURE		GRIP PISTOL FOR RIFLE 7.62mm. 1A & 1A1		MATERIAL	NYLON 66 HEAT STABILISED TO SPECN. DEF STAN 93-8/1	DGNR'S REF. CISA 291.SHT.No.1 No. OF SHTS - 9
				HT /HARDNESS		PART No.
				PROTECTIVE FINISH		DRG. No.
						DS CAT. 1005-004031