

91-14-99z

UNLESS SPECIFIED OTHERWISE

TECHNICAL CONDITIONS

1. PROVIDE DIMENSIONS WITHOUT DEVIATIONS MECHANICALLY MACHINED SURFACES, DIMENSIONS OF CASTING ± 0.2 AS PER ACCURACY CLASS 7 DSTIMO
2. CASTING DRAFTS MAXIMUM 2°
3. UNSPECIFIED CASTING RADII R4
4. OTHER REQUIREMENTS ARE AS PER TUL-408
5. AFTER CUTTING OF CLAMP, DISTORTION OF DIMENSION 5 IS ALLOWED.

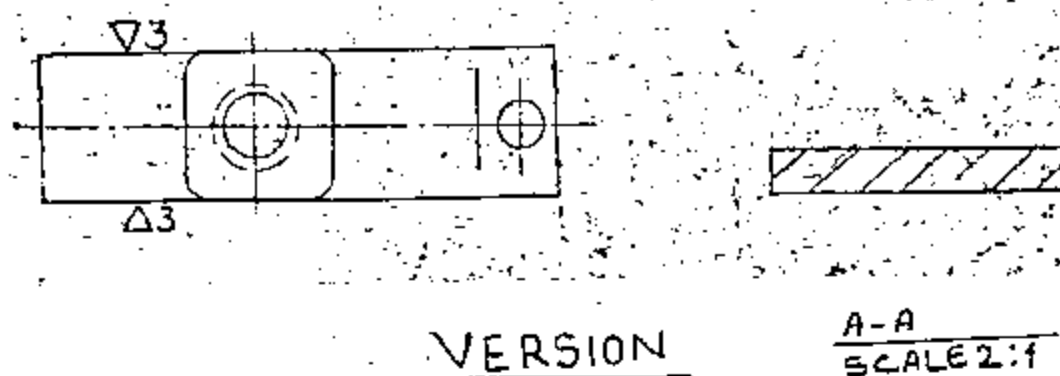
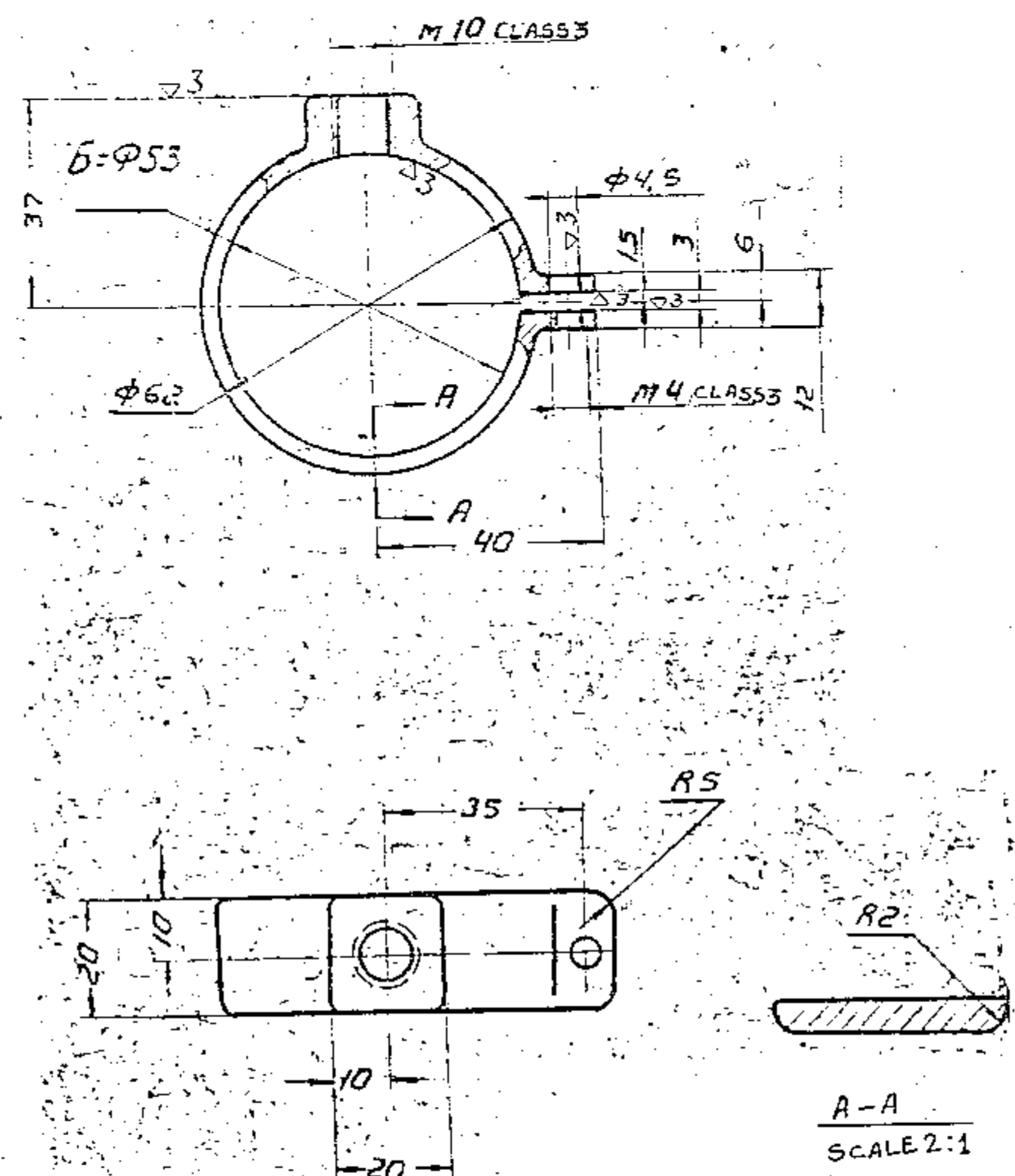

- NOTE:
1. ALL DIMENSIONS ARE IN MM.
 2. THE ABBREVIATIONS AND SYMBOLS ARE BASED ON RUSSIAN SPECIFICATIONS.

NEAREST SOVT MATERIAL		R19	
GOST 2685-75			
ORIG. MATERIAL	DATE	ISSUE	REVISIONS
ALL CHAMFERED & CONNERS TO BE ROUNDED OFF.	ALL THREADS TO CONFORM TO SPECIFICATION.	STAMP OR ETCH, PART NO. MANUFACTURED IN NAME & YEAR OF MFR.	
DWG. NOT TO BE SCALED	TOLERANCE ON DIMENSIONS UNLESS OTHERWISE SPECIFIED	USED ON:-	
SCALE:- 1:1		773-82-c8106	
DATE :- 24.12.73			
DRAWN BY	WT:-(Kg)	CLAMP	
CHKD.	0.04		
APP. B.S.		DRAWING NO	PART NO
		766-71-15	
CONTROLLERATE OF QUALITY ASSURANCE (INFANTRY COMBAT VEHICLES)			

EXPERIMENTAL