

SKM-283*2

SA (SA)	J.W.M. D/O	D.A. No.
sd/	sd/	M 38/83
sd/	sd/	M 15/94

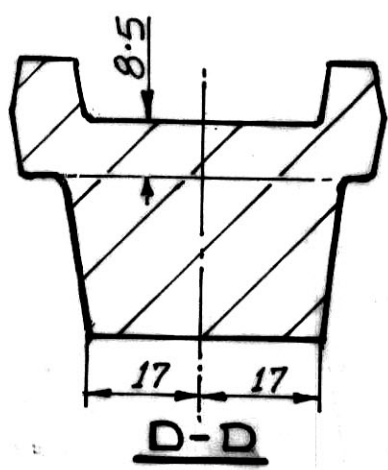
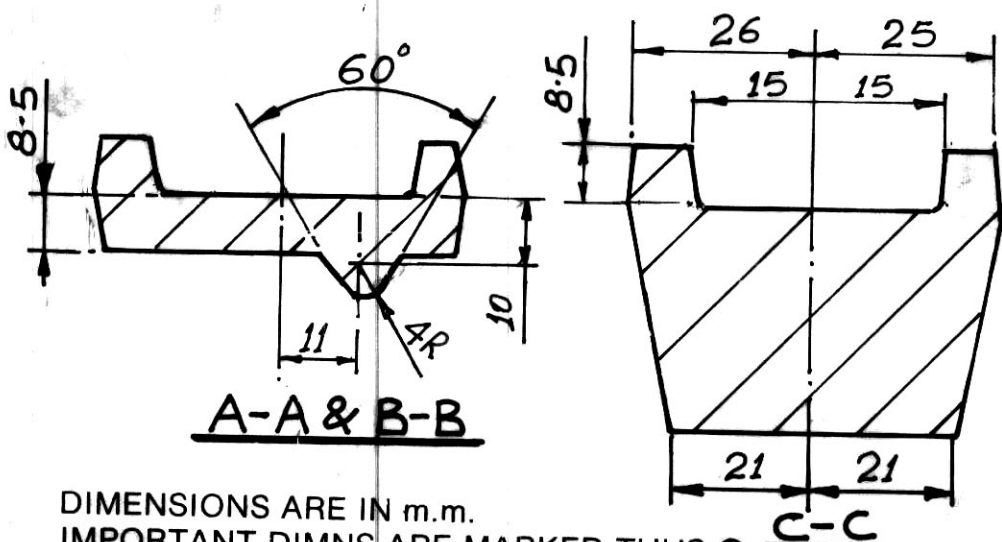
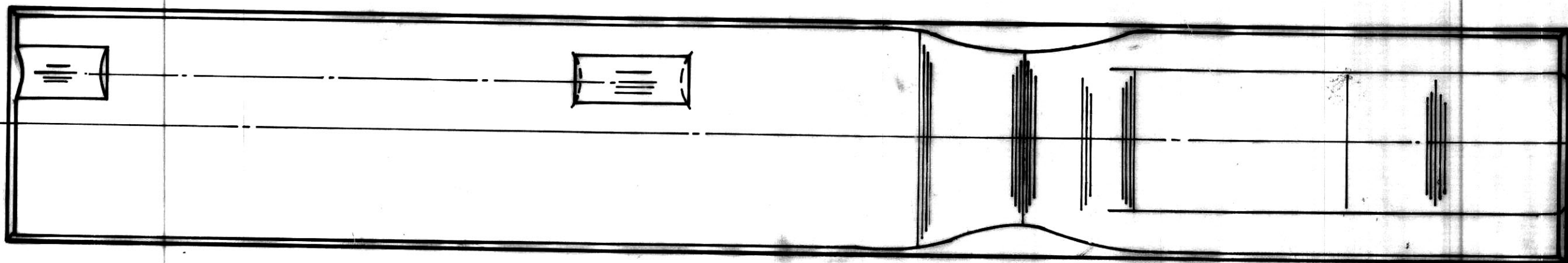
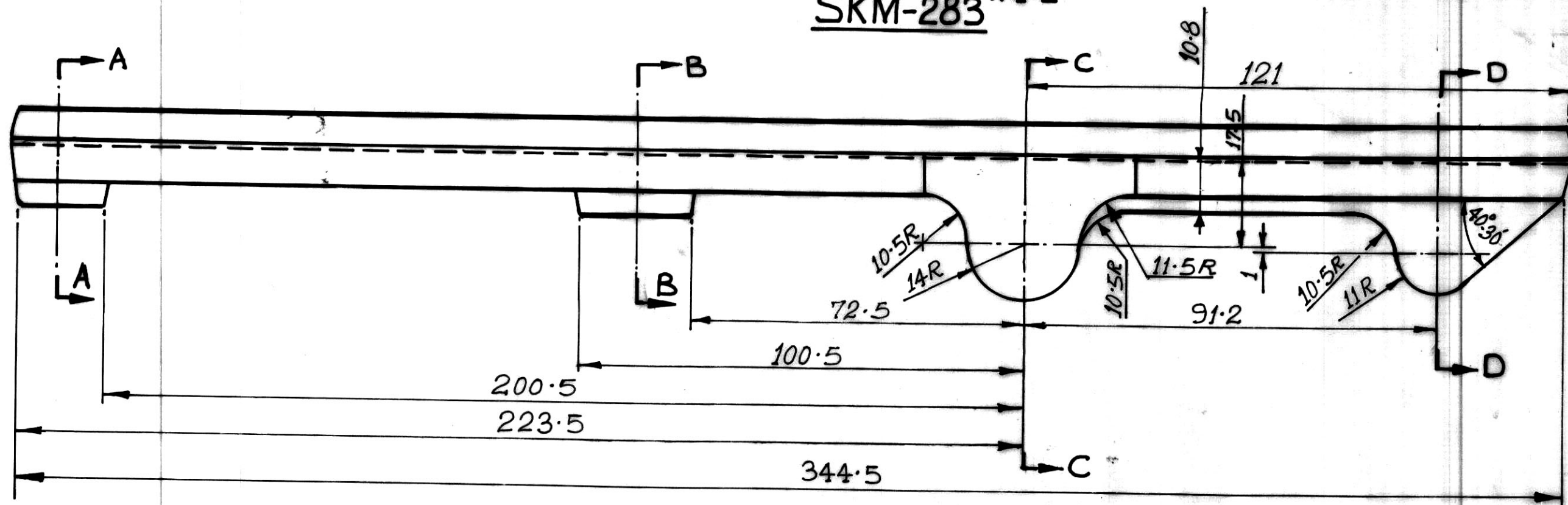

NOTE:- DRAFT ANGEL 7° ALL OVER
 TOLERANCES ON ALL DIMS. AREAS PER IS: 3469 (PART I-III) 1973
 ALL SHARP CORNERS TO BE BLENDED 2.9 R MAX.
 NORMALISED (HARDNESS 210-250 H·B)

DIMENSIONS ARE IN m.m.
 IMPORTANT DIMNS ARE MARKED THUS ⊕
 INFORMATION MKD. THUS 'T' TO BE MARKED ON SURFACES MARKED 'G' TO BE GRD.
~~MATL: BS 970 P11 72 STEEL GR. 060 A62 OR 080 (EN-43D) OR 060 A67 OR 080 A67 (EN-43B) OR 070M55 (EN-9)~~

MATL:- BS 970 P6Z 1983GR 060 A62 OR A67 OR 080 A62 OR A67

GUN MACHINE 7.62 mm (TK-71)
FORGING DRG. FOR PLATE BOTTOM
DRG. NO. 7025 F

SCALE

SMALL ARMS FACTORY, KANPUR.

DRAWN	TRACED	CHKD
sd/	sd/	sd/
DATE	14.12.96	
APPROVED		
G.A.E (SA)		J.W.M./D.O.
DRG. NO.		
SKM-283*2		
SHEET 1		OF 1

ORIGINAL DATE OF APPROVAL 24.10.74

COMPARED BY-

24.10.74

G.A.E (SA)