

2A42.06.025

Rz40

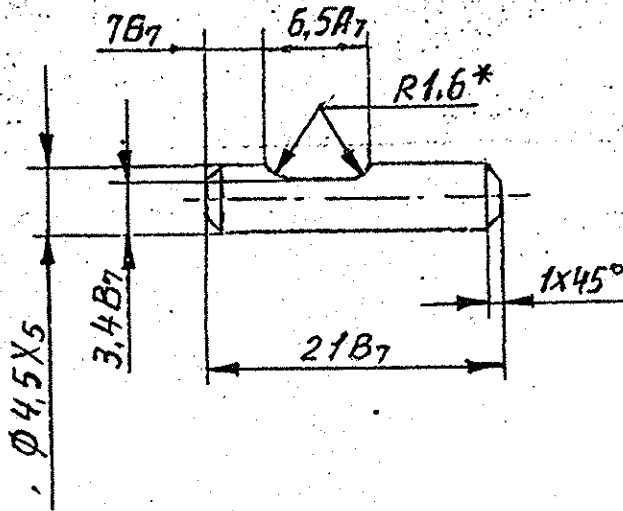

ROD

Scale 2:1. Material: steel 30XPA, OCT 3-98-80. Mass: 0.002

- (1) 1. HRC₃ 43.5 to 51.5. Test hardness on reference sample
2. Round off sharp edges to $R \approx 0.6$ mm
3. *Ensure size by tools
4. Coating: cadmium plating (layer of 3μ) $F = 0.033$; accelerated phosphating with chromate treatment and impregnation with adhesive БФ-4, ГОСТ 12172-74, one layer
5. Stamp K and W on the lot tag

37000000 704 С ПОДПИСИ НА КАРТОНЕ
 11-384-84 Т. 81, 28. 28.88

FINAL DRG FOR MFR. AT OFT
 DATE 09-07-97
 UP-DATED *[Signature]*
 CHECKED *[Signature]*
 F/M-PROJ
 CT-COPY VERIFIED: *[Signature]* 10.08.91
 DGM/PROJ. *[Signature]* 26(8)9.1

2A42	
2A42.06.025	
ROD	
СТЕРЖЕНЬ	0,002 2:1
СТЕЖИВ 30XPA	
OCT 3-98-80	