

First use		Format	Zone	Position	Designation	Nomenclature	Qty.	Remarks					
						<u>Documents</u>							
	A1	/			Ya-AO-18.000SB	Assembly drawing							
Reference No.						<u>Assembly units</u>							
	A4	/	1		Ya-AO-18.010	Box body	1						
	A4	/	2		9-Ya-621.100	Box cover	1						
	A4	/	3		Ya-AO-18.030	Upper front pyramid	1						
	A4	/	4		Ya-AO-18.040	Lower front pyramid	1						
	A4	/	5		Ya-AO-18.050	Lower middle pyramid	1						
	A4	/	6		Ya-AO-18.060	Upper middle pyramid	1						
	A4	/	7		Ya-AO-18.070	Upper rear pyramid	1						
	A4	/	8		Ya-AO-18.080	Lower rear pyramid	1						
Sign and Date						<u>Components</u>							
	WD	/	9		Ya-AO-18.032	Felt sheet PPr A6-T GOST 6308-71-GOST 15159-76 (200x200) mm	4						
	WD	/	10		Ya-AO-18.033	Cover belt Strap LR L-25-Bch-4 OST 17-133-87 l= 350 mm	1						
Sign and Date		<b>Ya-AO-18.000</b>											
Orig. Inv. No.		Amend.	Sheet	Doc. No.	Sign	Date							
Sign and Date		<b>Packing box</b>					Type	Sheet	Sheets				
Dupl. Inv. No.							Developed by				02	1	4
Alternate Inv. No.							Checked by						
Sign and Date							Head of Q.C.D						
Sign and Date		Approved by											

Format	Zone	Position	Designation	Nomenclature	Qty.	Remarks
WD	/	11	Ya-AO-18.034	Strut wood chip board Coniferous type wood, grade 2 GOST 8486-86 (500x300x36) mm	1	
WD	/	12	Ya-AO-18.035	Gasket Plate 1F-MBS-M-5 GOST 7338-90 (5x20x500) mm	11	
WD	/	13	Ya-AO-18.036	Wire 1.0-0.4 GOST 3282-74 l = 2200 mm	4	
A3	/	14	9-Ya-621.033	Strap	4	
A3	/	15	9-Ya-621.034	Base plate	4	
A3	/	16	9-Ya-621.035	Handle	4	
A3	/	28	AK-630Ya 200-1-32 TR	Pocket for packing list 1TR	1	
A4	/	30	2Ya28.039	Bolt		16 nos. Replacement with pos.17 permissible
WD	/	31	Ya-AO-18.037	Support, wood chip board Coniferous type wood, grade 2 GOST 8486-86 (20x80x350) mm		
			<b>Ya-AO-18.000</b>			Sheet 2
Amend.	Sheet	Doc. No.	Sign	Date		

Copied by

Format A4





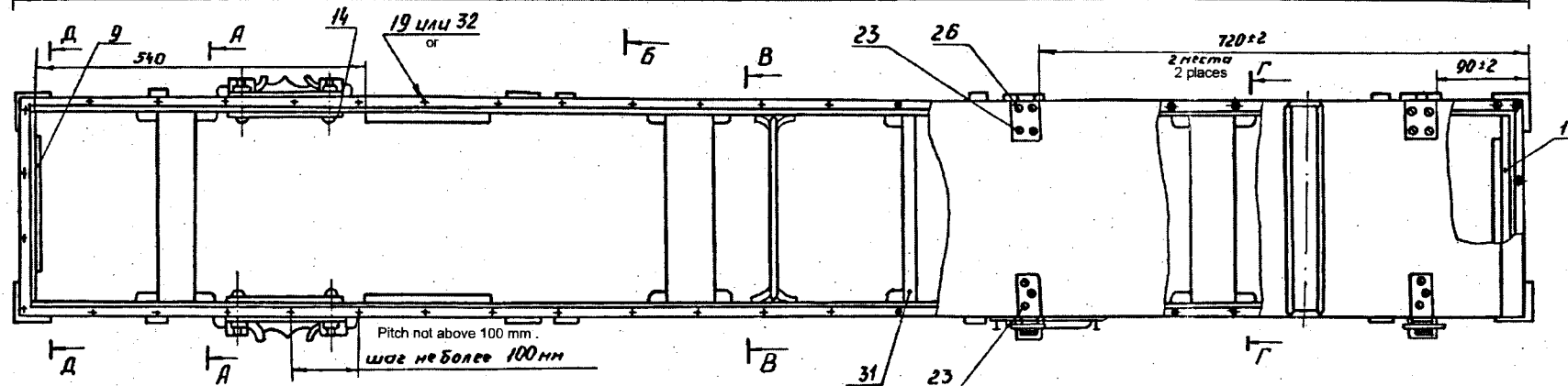
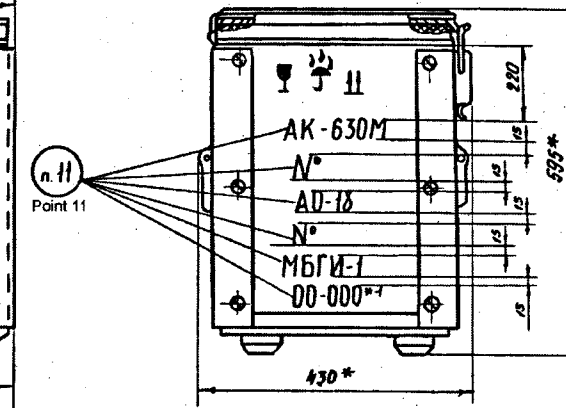
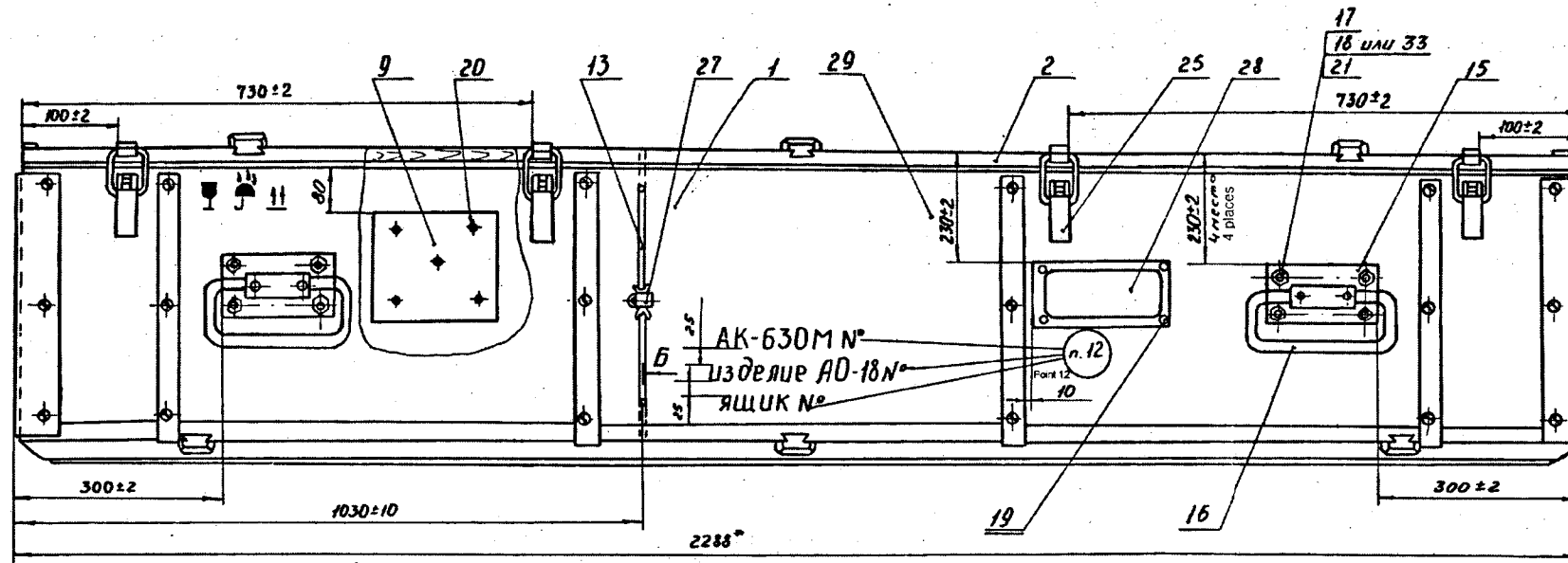

Sketch of belt tightening  
Схема крепления ремня.

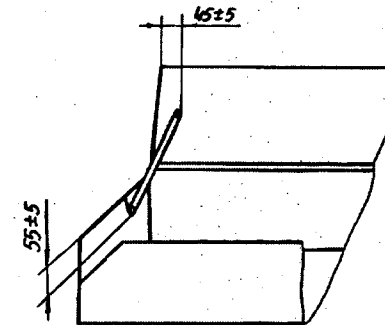

А-А повернуто

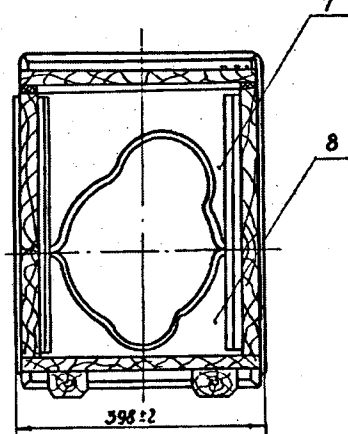

В-В повернуто

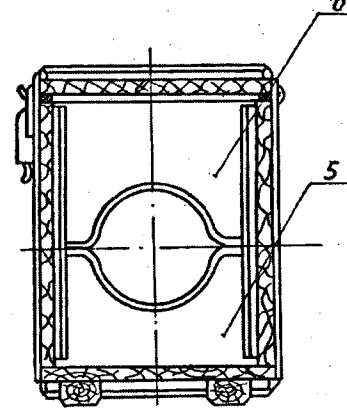

Г-Г повернуто

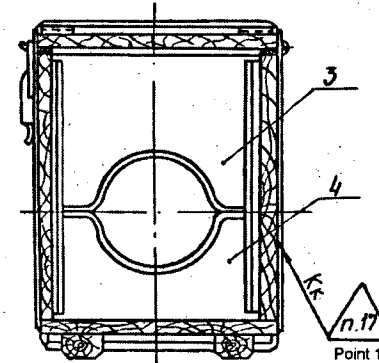

Д-Д повернуто Cover conventionally open.

Крышка условно открыта

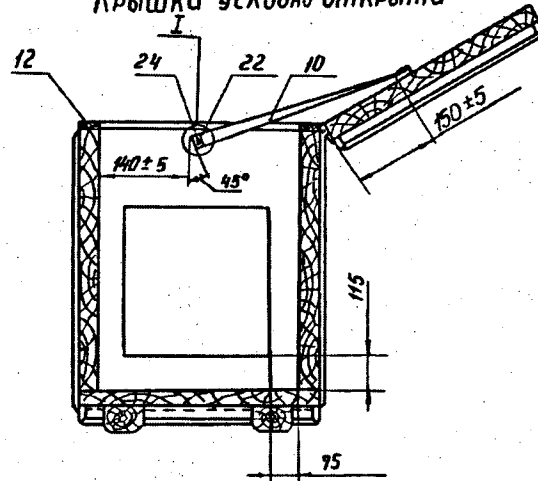

И  
М1:1

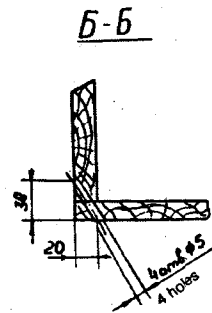
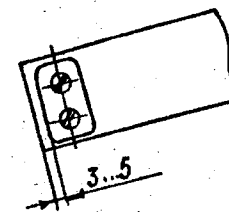

Refer sheets 2,3 for specification.

Inv. No. Sign & Date Alternat. Inv. No. Duplicate Inv. No. Sign & Date First remarks

				Ya - AO-18.000 SB			
Amend	Sheet	Doc. No.	Sign	Date	Type	Weight	Scale
Developed by					O <sub>1</sub>	86.0	1:5
Checked by					Sheet 1		Sheets 3
Technician							
Head of bureau							
Head of G.C.D.							
Approved by							

**Technical requirements**

1. \*Reference dimensions.
2. Rubber gasket pos.12 is mounted using glue 88-SA TU 38.105.1760-89.
3. Ensure tight fitting of cover pos.2 with box pos.1 during fixture of loop pos.26 and locks 25.
4. Line inner surface of the box with paper DB GOST 8828-89. Fix the paper using nails pos.19 or clamps pos.32. Carry out lining after coating.
5. Fix plates pos.9 using nitro glue AK-20 TU 6-10-1293-78 and nail with nails pos.20.
6. Coating: Enamel KhV-124, gray GOST 10144-89, external surface- 2 coats, inner surface- 1 coat.
7. After putting the article in box, place strut pos.11 on front part of article- felt should be directed toward article AO-18.
8. Planing upper pyramids is permissible in order to provide tight and firm fastening of the article.
9. Seal the box after packing art. AO-18.
10. Mark handling instructions on two adjoining side plates at upper left corner, in size for tag No.2 , shown in table No.1,3,11 of annexure 4 GOST 14192-96.
11. Mark in letter size 30 as per GOST 14192-96 on two mutually opposite side plates.  
Numbers with mark \*1 denote month and year of preservation of article AO-18.  
Inscription <<MGBI-1>> should be done only when preserved in anti corrosion paper MBGI as per GOST 16295-93.
12. Mark in letter size 50 as per GOST 14192-96 point 4.6.

Orig. Inv. No. Sign and Date Alternate Inv. No. Sign and Date Dupl. Inv. No. Sign and Date

					<b>Ya-AO-18.SB</b>	Sheet
Amend.	Sheet	Doc. No.	Sign	Date		2

Copied by

Format A4

13. Mark as per point 10,11,12 in symmetry, using enamel EP-51, black GOST 9640-85.

14. Additional requirements for making boxes.

14.1 Moisture level of wood should not be higher than 18%.

14.2 Blue stains are not permissible on wooden parts of the box.

14.3 Blunt wane and decrease in surface finish of component surfaces are not permissible.

14.4 Nails should have phosphate coating (Chem.phos.).

14.5 Metallic fixtures should have phosphate coating with lacquer BT-987 GOST 6244-70 impregnation in single layer V.Ж<sub>4</sub>.

14.6 Wood screws, screws, bolts, nuts, washers and wire should have protective zinc coating (Zn6).

14.7 Box should be painted in assembled form with mounted metallic fixtures.

14.8 Other technical requirements as per GOST V6454-75 for boxes type II.

15. Support pos.31 is meant for excluding any movement of shelf AO-18P3.000 along box and is fixed after its placement.

16. Placement of article AO-18 and spare parts is carried out in following manner:

1) Shelf AO-18P3.000 and spare parts are placed at bottom of the box between component pos.31 and assembly unit pos.4.

2) Article AO-18 is placed in pyramids.

3) Bag AO-18S.000 with tool and accessories is placed on top of article AO-18 between assembly unit pos.3 and 6.

17. Stamp.

Orig. Inv. No.	Sign and Date	Alternate Inv. No.	Dupl. Inv. No.	Sign and Date	Ya-AO-18.SB					Sheet
										3
Amend.	Sheet	Doc. No.	Sign	Date						Format A4

Copied by

Format A4

9-Ya-621.033

First use

Reference No.

Sign and Date

Duplicate Inv. No

Alternate Inv. No

Sign and Date

Orig. inv. no.

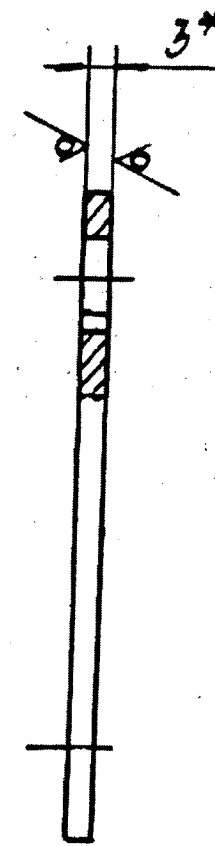
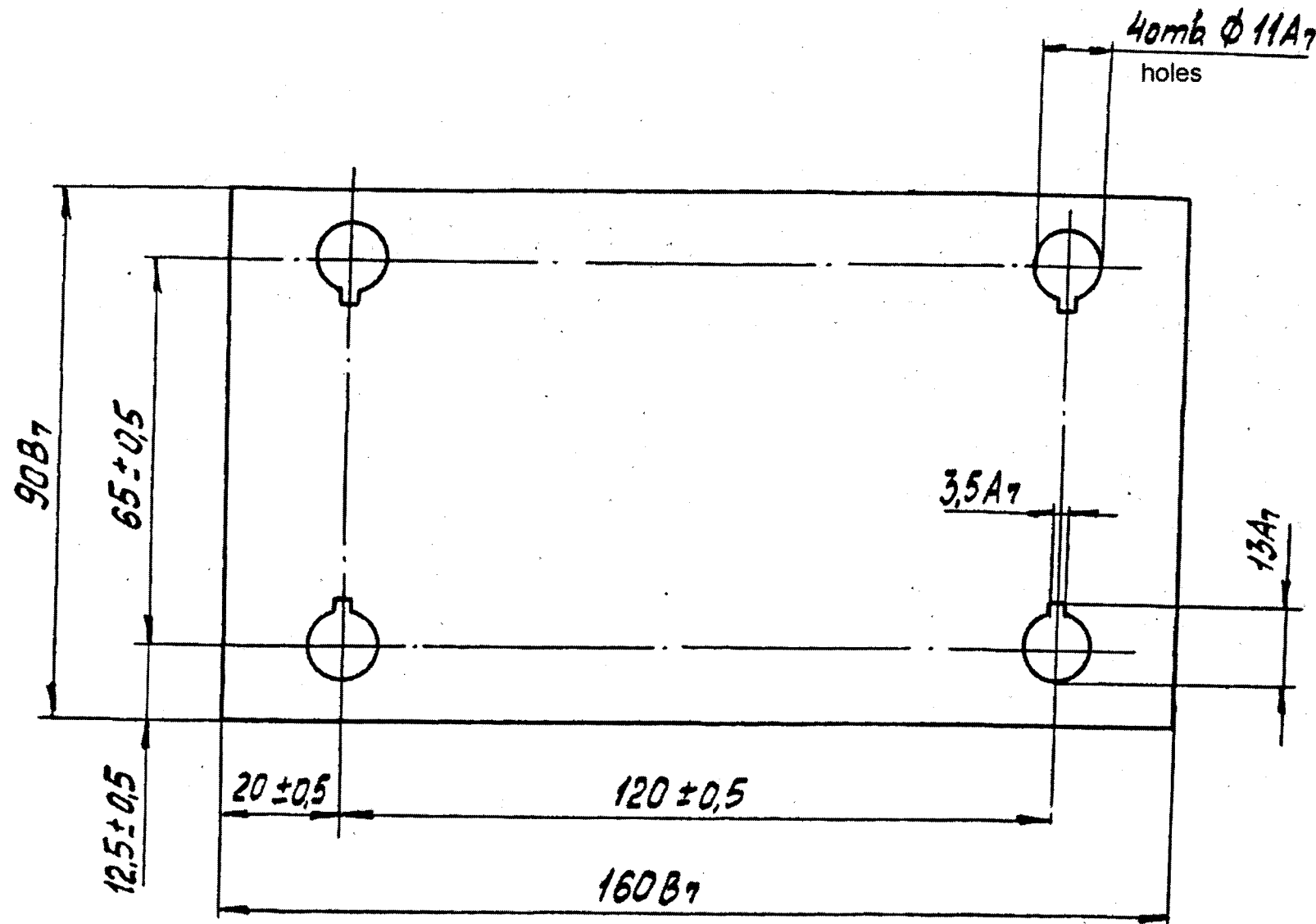

R<sub>280</sub> / (✓)

- 1.\* Reference dimension.
2. Round off sharp edges R~0.6 mm.
3. Coating Chem. phos. accel.Cr./impregnation with adhesive BF-4 GOST 12172-74, single coat.
4. Stamp K on batch tag.

					9-Ya-621.033			
Amend.	Sheet	Doc.No.	Sign	Date	Strap	Type	Weight	Scale
Developed by						O <sub>2</sub>	0.33	1:1
Checked by						Sheet	Sheets 1	
Head of Q.C.D						Sheet $\frac{B - PN - 0 - 3GOST19903 - 74}{4 - III - 25GOST16523 - 97}$		
Approved by								

9-Ya-621.034

First use

Reference No.

Sign and Date

Duplicate Inv. No

Alternate Inv. No

Sign and Date

Orig. inv. no.

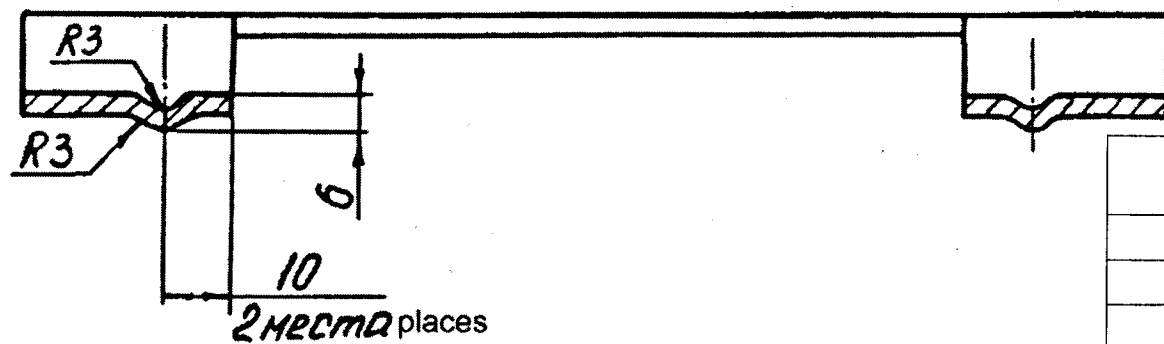
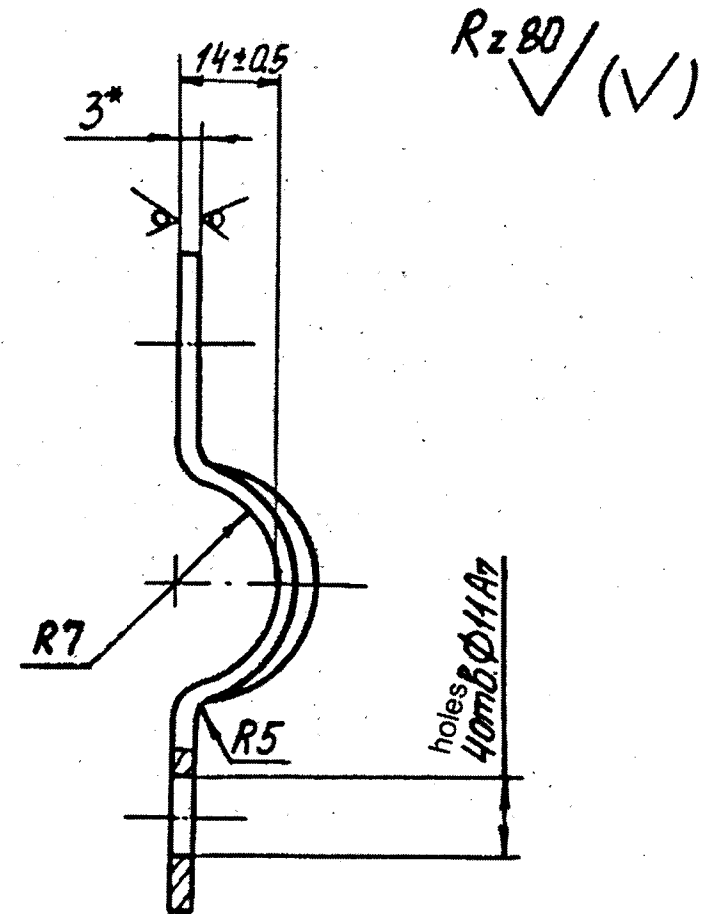
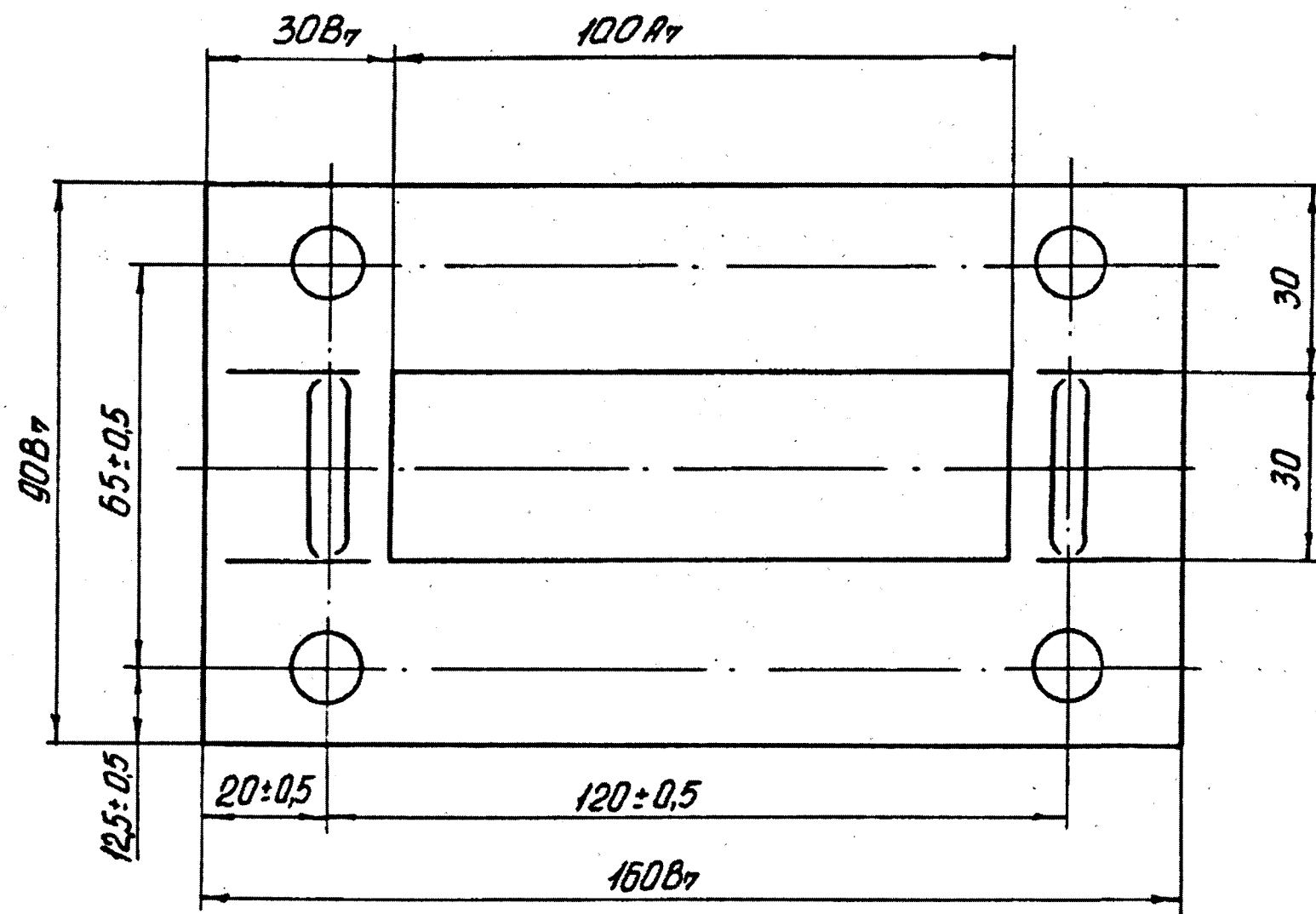

- 1.\* Reference dimension.
2. Round off sharp edges R~0.6 mm.
3. Roll over width = 105 mm.
4. Coating Chem. phos. accel.Cr./impregnation with adhesive BF-4 GOST 12172-74, single coat.
5. Stamp K on batch tag.

					9-Ya-621.034			
Amend.	Sheet	Doc.No.	Sign	Date	Base	Type	Weight	Scale
Developed by						O <sub>2</sub>	0.33	1:1
Checked by						Sheet	Sheets 1	
Head of Q.C.D					Sheet $\frac{B-PN-0-3GOST19903-74}{4-III-25GOST16523-97}$			
Approved by								

9-Ya-621.035

First use

Reference No.

Sign and Date

Duplicate Inv. No

Alternate Inv. No

Sign and Date

Orig. inv. no.

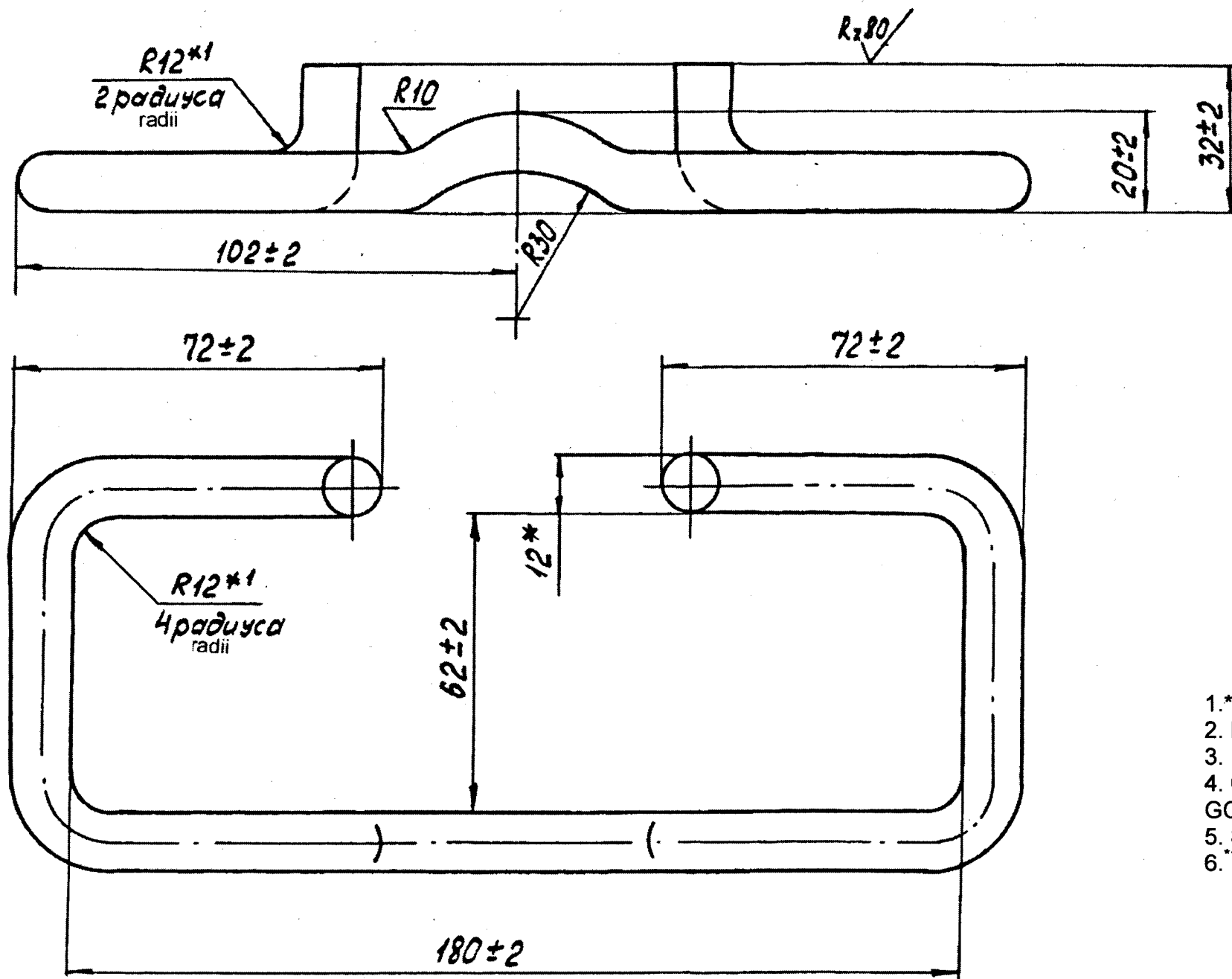

- 1.\* Reference dimension.
2. Roll over length ~465 mm.
3. Round off sharp edges R~0.6 mm.
4. Coating Chem. phos. accel.Cr./impregnation with adhesive BF-4 GOST 12172-74, single coat.
5. Stamp K on batch tag.
- 6.\*<sup>1</sup> Dimensions ensured by tool.

					9-Ya-621.035			
Amend.	Sheet	Doc.No.	Sign	Date	Handle	Type	Weight	Scale
Developed by						O <sub>2</sub>	0.35	1:1
Checked by						Sheet	Sheets	1
Head of Q.C.D					Wheel			
Approved by						$\frac{12 - 5GOST7417 - 75}{35 - VGOST1051 - 73}$		

First use								
Reference No.								
Sign and Date	Alternate Inv. No.	Duplicate Inv. No.	Sign and Date	<p style="text-align: right;"><i>Rz 80</i> ✓ (✓)</p> <ol style="list-style-type: none"> <li>1. Blunt sharp edges ~0.4 mm.</li> <li>2. Coating: Cd12.Phos.</li> <li>3. Apply inscriptions with enamel PF-115, white GOST 6465-76. Letter size PO-10 GOST 2930-62.</li> <li>4. Inscriptions in English PACKING LIST.</li> <li>5. Mark Ч, Ш and stamp K on tag.</li> </ol>				
Orig. inv. no.	Sign and Date	Alternate Inv. No.	Sign and Date					

					AK-630-Ya 200-1-32 TR			
Amend.	Sheet	Doc. No.	Sign	Date	Pocket for packing list 1TR	Type	Weight	Scale
Developed by						A		1:1
Checked by						Sheet	Sheets	1
Head of Q.C.D					Sheet $\frac{B - PN - 0.5 \times 1000 \times 2000 \text{ GOST } 19904 - 74}{II - sh - VG - 08KPGOST9045 - 80}$			
Approved by								



Format	Zone	Position	Designation	Nomenclature	Qty.	Remarks		
<u>Documents</u>								
A1	✓		Ya-AO-18.010SB	Assembly drawing				
<u>Assembly units</u>								
A4	✓	1	9-Ya-621.020	Bottom plate of box	1			
A4	✓	2	Ya-AO-18.100	Side plate	2			
A4	✓	16	Ya-AO-18K.100	Angle piece	4			
<u>Components</u>								
A3	✓		Ya-AO-18.003	Face plate	2			
A3	✓		9-Ya-621.006	Skid	2			
A4	✓		9-Ya-621.007	Strap	2			
A3	✓		9-Ya-621.008	Tie	1			
A4	✓		9-Ya-621.009	Strap	2			
A3	✓		9-Ya-621.011	Clamp	4			
A4	✓		9-Ya-621.012	Washer	6			
A4	✓		9-Ya-621.013	Pocket plate	1			
A4	✓		9-Ya-621.014	Beam	2			
<b>Ya-AO-18.010</b>								
Amend.		Sheet	Doc. No.	Sign	Date			
Developed by				<b>Box</b>		Type	Sheet	Sheets
Checked by						02	1	3
Head of Q.C.D								
Approved by								





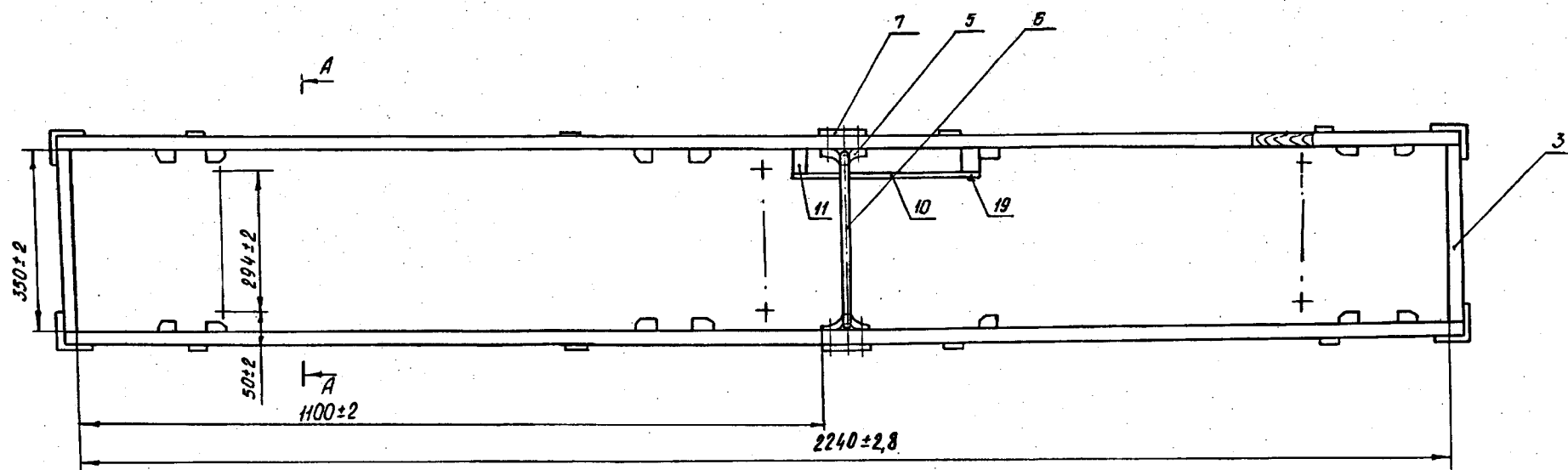
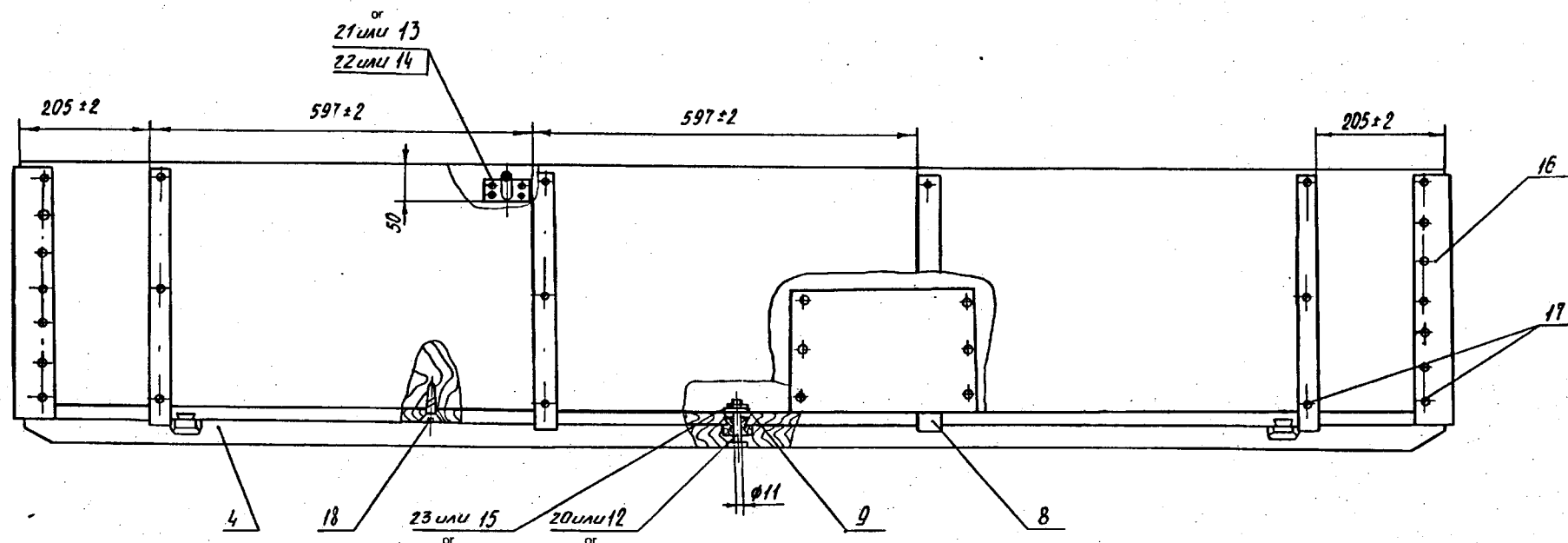

A-A повернуто  
turn

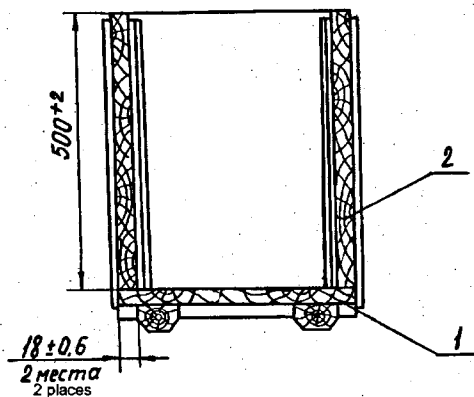

1. During joining Sb pos. 2 and comp. Pos. 3 of box casing, matching of lines of boards on height by which they are assembled is not permissible.
2. Ensure tight fitting of sb. Pos. 2 to sb. Pos. 1 during joining of sb. Pos. 1 to sb. Pos. 2.
3. Carry out joining of walls of casing box with straight pins.
4. Carry out application of adhesive FR-12 TUG-05-1748-81 on fitting pins.
5. Fasten assembly Pos. 1 with assembly Pos. 2 by the help of wood screws pos. 18.
6. Bolt head Pos. 12 should not be projected beyond the surface of component Pos. 4.
7. Place component pos. 1, 2 and 3 from opened side inside the casing box.
8. Set component pos. 10.11.19 during covering with paper from inside the surface of casing box Ya-AO-18.000.

Inv. No. Sign & Date Alternate Inv. No. Duplicate Inv. No. Sign & Date First Remarks

YA-AO-18.010 SB				Type	Weight	Scale	
Amend	Sheet	Doc. No.	Sign	Date	0	50.500	1:5
Developed by					Sheet		Sheets 1
Checked by							
Technician							
Head of bureau							
Head of Q.C.D							
Approved by							



9-Ya-621.009		First use	
Approved by shop		Reference No.	
Approved KTON.		Sign and Date	
Approve Osb		Dupl. Inv. No.	
Alternate Inv. No.		Sign and Date	
Approved OGMet		Sign and Date	
Orig. Inv. No.		Sign and Date	

holes  
40mm  $\phi 6,4A5$

$Rz 80 / \checkmark(\checkmark)$

point 3  $R3$

1. Blunt edges  $R \sim 0.2$  mm.  
 2. Coating: Chem. phos. accel. Oil.  
 3. Stamp.

9-Ya-621..009				
<b>Strap</b>		Type	Weight	Scale
		O <sub>2</sub>	0.037	2:1
		Sheet	Sheets 1	
Sheet		B3GOST19903 - 74		
		III - 25GOST16523 - 97		

Copied by

Format A4



9-Ya-621.013

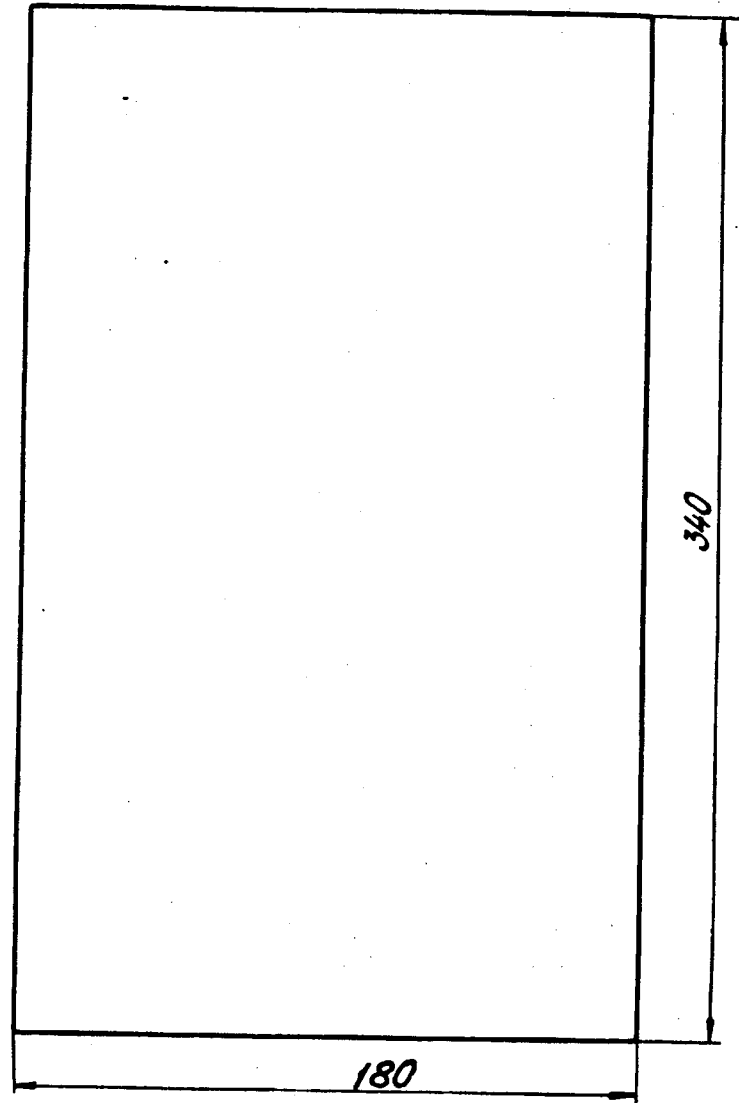

Approved OGMet		Sign and Date		Approved KTO(,...		Approved by shop		First use	
		Orig. Inv. No.		Sign and Date		Dupl. Inv. No.		Reference No.	
Amend.		Sheet		Doc. No.		Sign		Date	
Developed by		Checked by		Head of Q.C.D		Design bureau chief		Head of Q.C.D	
Approved by		Copied by		Format A4		Type		Weight	
						O <sub>2</sub>		0.140	
						Sheet		Sheets 1	
						Scale		1:2	
						Side plate of pocket		Birch pasted ply FK grade AB/B-4 GOST 3916-96	

9-Ya-621.013

Side plate of pocket

Birch pasted ply FK grade  
AB/B-4 GOST 3916-96

Copied by

Format A4

9-Ya-621.014						
Approved OGMet	Orig. Inv. No.	Sign and Date	Alternate Inv. No.	TOSb	Approved KTCivl	
		Approved by shop	Reference No.	First use		
9-Ya-621.014						
				Type	Weight	Scale
Beam				O <sub>2</sub>	0.101	1:2
				Sheet	Sheets 1	
Coniferous lumber grade2 GOST 8486-86						

Copied by

Format A4



9-Ya-621.011

First use

Reference No.

Sign and Date

Duplicate Inv. No

Alternate Inv. No

Sign and Date

Orig. inv. no.

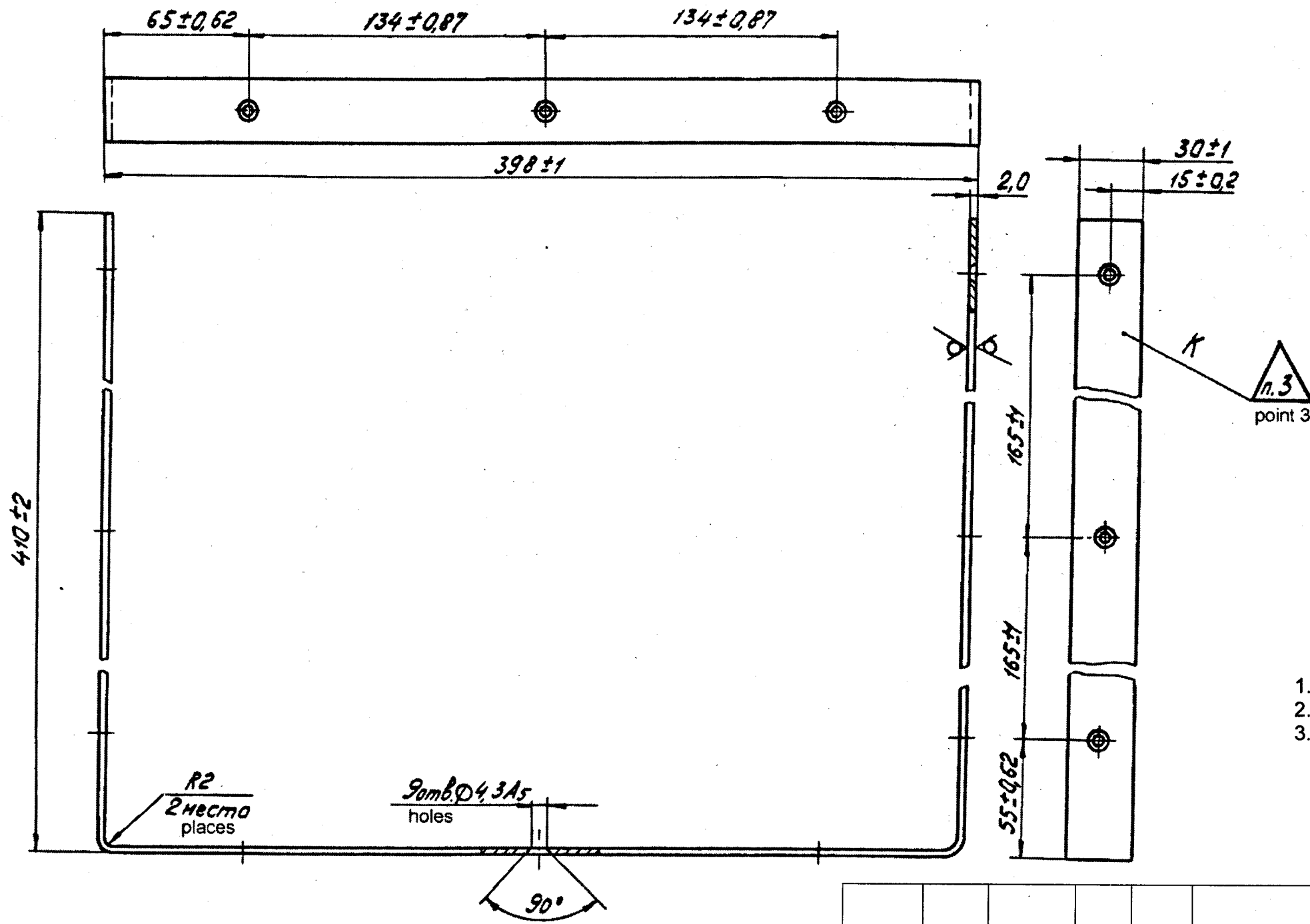

1. Blunt sharp edges ~0.2 mm.
2. Coating: Chem.phos.accel.Oil.
3. Stamp.

					9-Ya-621.011			
Amend.	Sheet	Doc.No.	Sign	Date	Clamp	Type	Weight	Scale
Developed by						O <sub>2</sub>	0.565	1:2
Checked by						Sheet	Sheets 1	
Head of Q.C.D					Sheet	B2GOST19903 - 74 III - 25GOST16523 - 97		
Approved by								

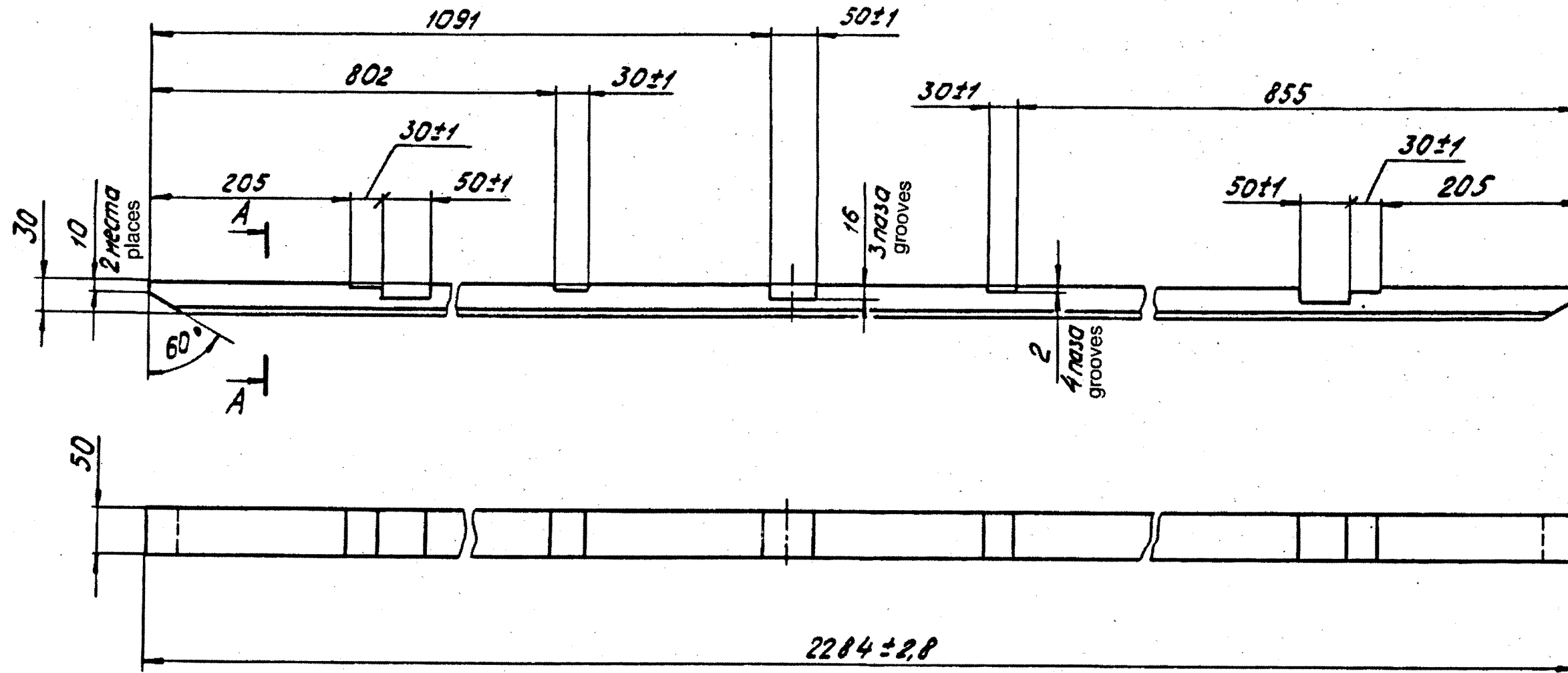

Rz max 800/10

A-A  
M1:2

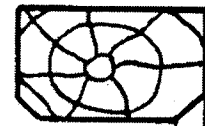

6 x 45°  
2 фаски chamfers

Make dimensions without tolerances as per js16 GOST 6449.1-82.

					9-Ya-621.006			
Amend.	Sheet	Doc.No.	Sign	Date	Slide	Type	Weight	Scale
Developed by						O <sub>2</sub>	1.582	1:5
Checked by						Sheet	Sheets 1	
Head of Q.C.D						Coniferous lumber, grade 2 GOST 8486-86		
Approved by								

$R_{zmax} 800/(\checkmark)$

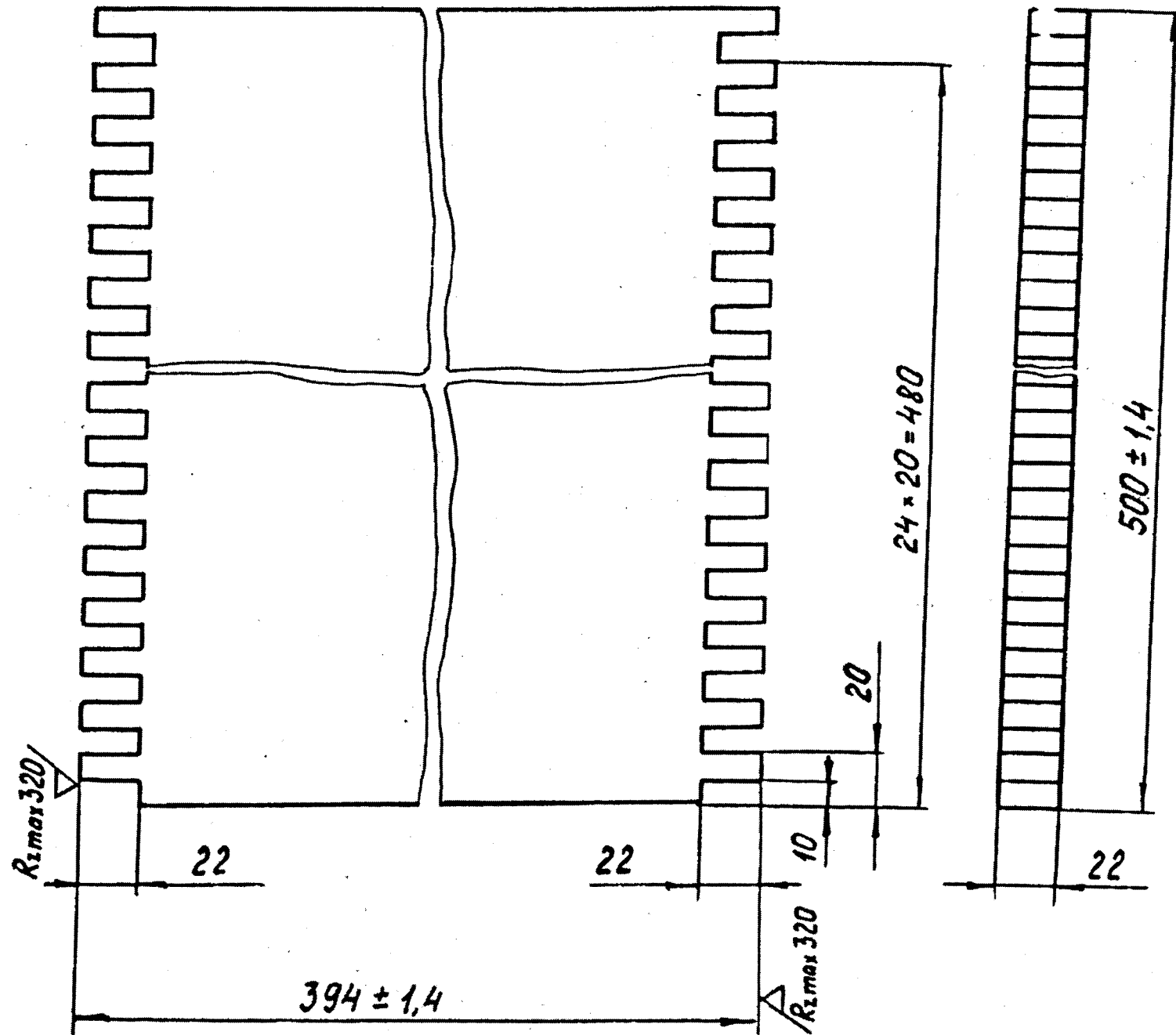

1. Non-planing of one of the sides with area not more than 40% and depth up to 2 mm is permissible.
2. Join the boards with each other in pile using glue FR -12 TU 6-05-1748-81.
3. Make tolerance dimensions as per js 16 GOST 6449.1-82.

					Ya - AO - 18.003			
Amen.	Sheet	Doc.No.	Sign	Date	Side plate	Type	Weight	Scale
Developed by						O <sub>2</sub>	2.060	1:2
Checked by						Sheet		Sheets 1
Head of Q.C.D					Lumber of coniferous type, grade 2 GOST 8486-86			
Approved by								

First use  
 Reference No.  
 Sign and Date  
 Duplicate Inv. No  
 Sign and Date  
 Alternate Inv. No  
 Sign and Date  
 Orig. inv. no.



9- Ya-621.020 SB

First use

Reference No.

Sign and Date

Duplicate Inv. No

Alternate Inv. No

Sign and Date

Orig. inv. no.

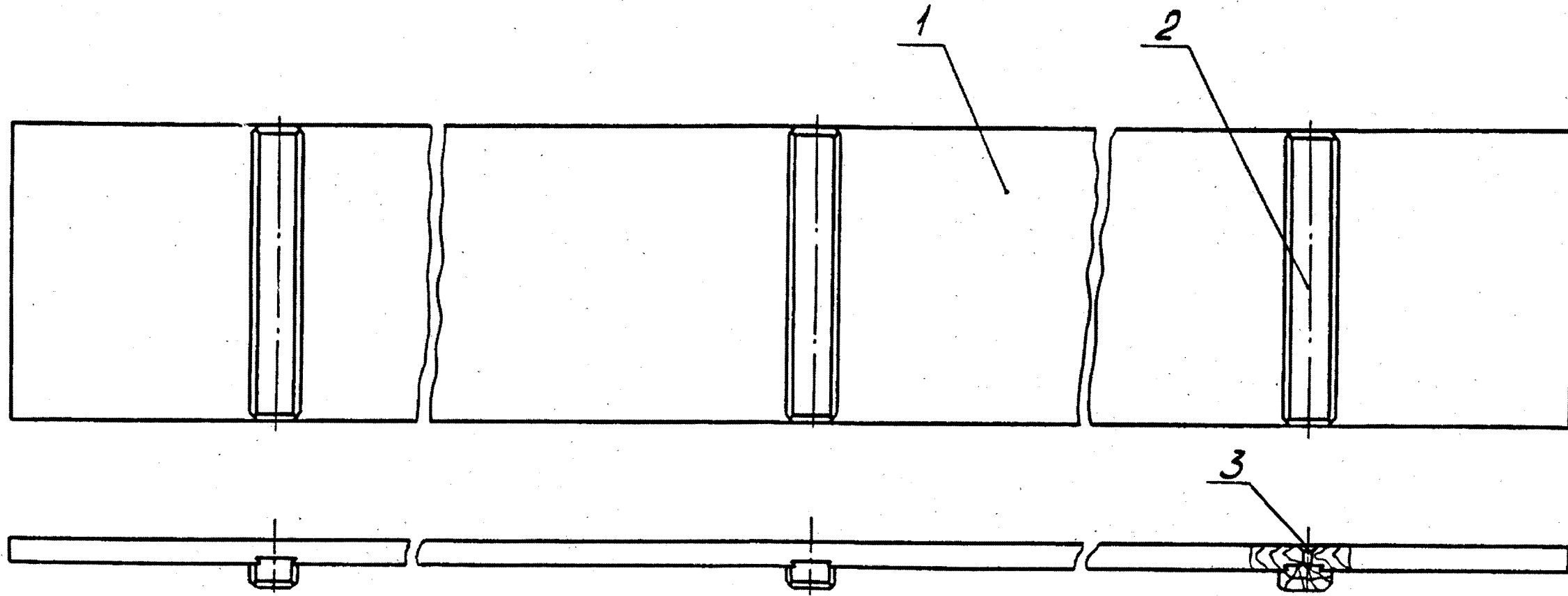

					9- Ya-621.020 SB				
					Bottom of box Assembly drawing	Type	Weight	Scale	
Amend.	Sheet	Doc.No.	Sign	Date		O <sub>2</sub>	10.400	1:5	
Developed by									
Checked by									
Head of Q.C.D									
Approved by									
						Sheet	Sheets	1	

Rz max 800/√(✓)

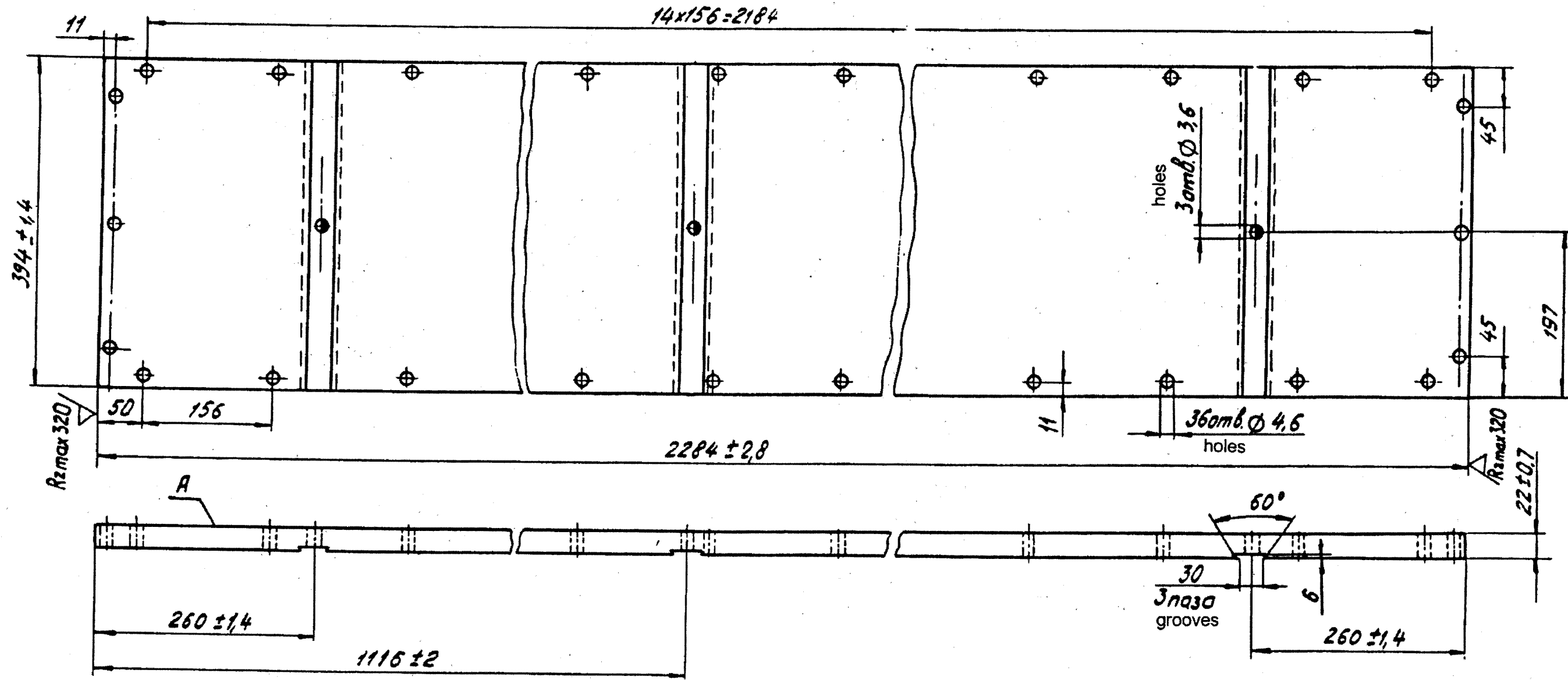

1. Absence of planning of surface A with area not more than 40% and depth up to 2 mm is permissible.
2. Boards are pasted with each other in tongue and groove joint with adhesive FR-12 TU6-05-1748-81.
3. Make dimensions without tolerances as per js16 GOST 6449.1-82.

					9-Ya-621.003			
Amend.	Sheet	Doc.No.	Sign	Date	Bottom of box	Type	Weight	Scale
Developed by						O <sub>2</sub>	9.780	1:5
Checked by						Sheet	Sheets	1
Head of Q.C.D						Coniferous lumber, grade 2 GOST 8486-86		
Approved by								

9-Ya-621.004

First use

Reference No.

Sign and Date

Duplicate Inv. No

Alternate Inv. No

Sign and Date

Orig. inv. no.

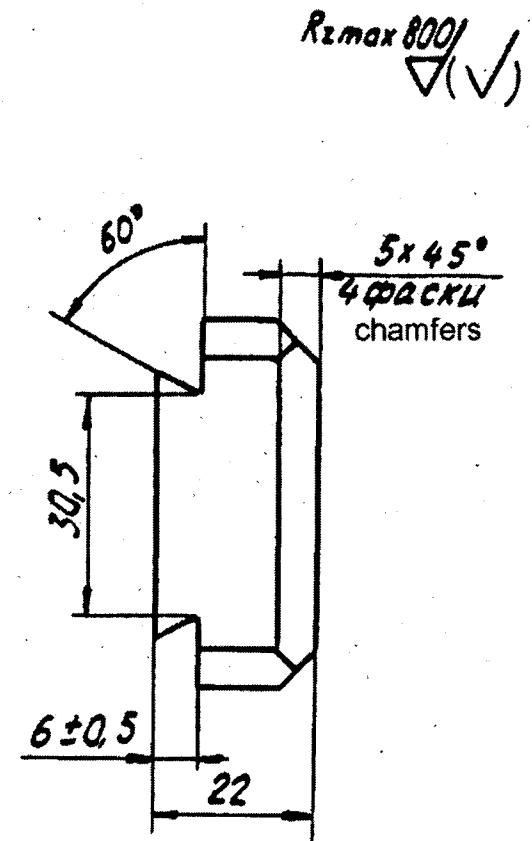
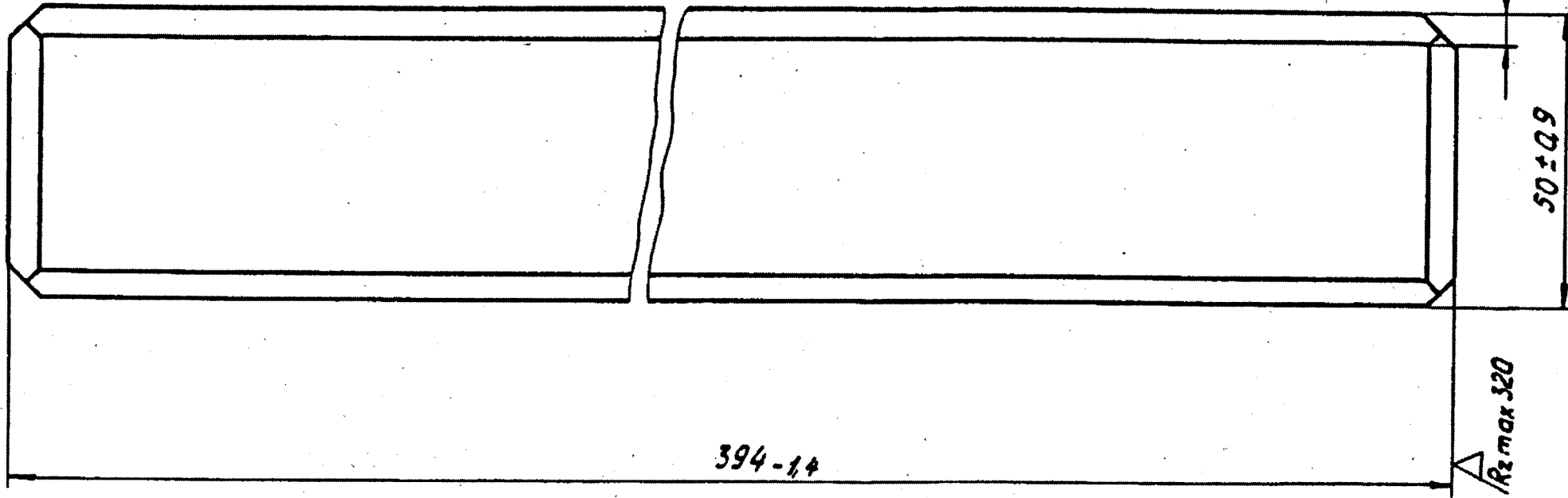

Make dimensions without tolerances as per js16 GOST 6449.1-82.

					9-Ya-621.004			
Amend.	Sheet	Doc.No.	Sign	Date	Key	Type	Weight	Scale
Developed by						O <sub>2</sub>	0.212	1:1
Checked by						Sheet	Sheets	1
Head of Q.C.D								
Approved by					Coniferous lumber, grade 2 GOST 8486-86			

First use		Format	Zone	Position	Designation	Nomenclature	Qty.	Remarks
						<u>Documents</u>		
	A3	/			Ya-AO-18.100SB	Assembly drawing		
Reference No.						<u>Components</u>		
	A3	/	1		Ya-AO-18.001	Side plate	1	
	A3	/	2		Ya-AO-18.002	Mounting strap	7	
						<u>Standard articles</u>		
			3			Nails K 2 x 40 GOST 4028-63	21	
Sign and Date								
Dupl. Inv. No.								
Alternate Inv. No.								
Sign and Date								
Orig. Inv. No.								
Sign and Date								
					<b>Ya-AO-18.100</b>			
		Amend.	Sheet	Doc. No.	Sign	Date		
		Developed by				Type	Sheet	Sheets
		Checked by				02		1
		Head of Q.C.D				<b>Side plate</b>		
		Approved by						

Ya-AO-18.000 SB

First use

Reference No.

Sign and Date

Duplicate Inv. No

Alternate Inv. No

Sign and Date

Orig. inv. no.

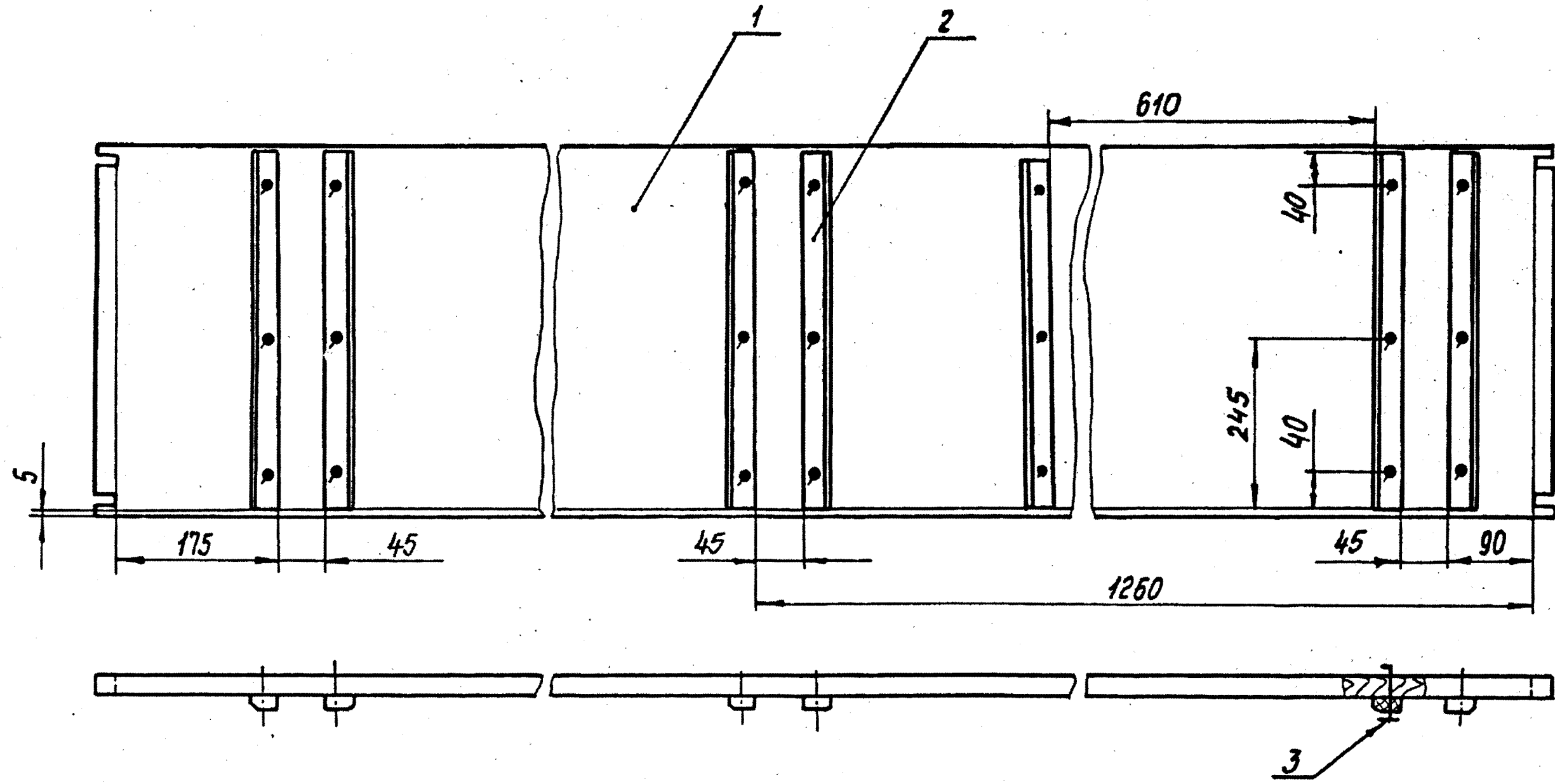

1. Bend projecting end of the nails along fibers.
2. Component pos.2 is mounted and fastened during lining of inner surfaces of box Ya-AO-18.000 with paper.

					Ya - AO-18.100 SB			
Amen.	Sheet	Doc.No.	Sign	Date	Side plate Assembly drawing	Type	Weight	Scale
Developed by						O <sub>2</sub>	13.300	1:5
Checked by						Sheet	Sheets 1	
Head of Q.C.D								
Approved by								

First use

Reference No.

Sign and Date

Duplicate Inv. No

Alternate Inv. No

Sign and Date

Orig. inv. no.

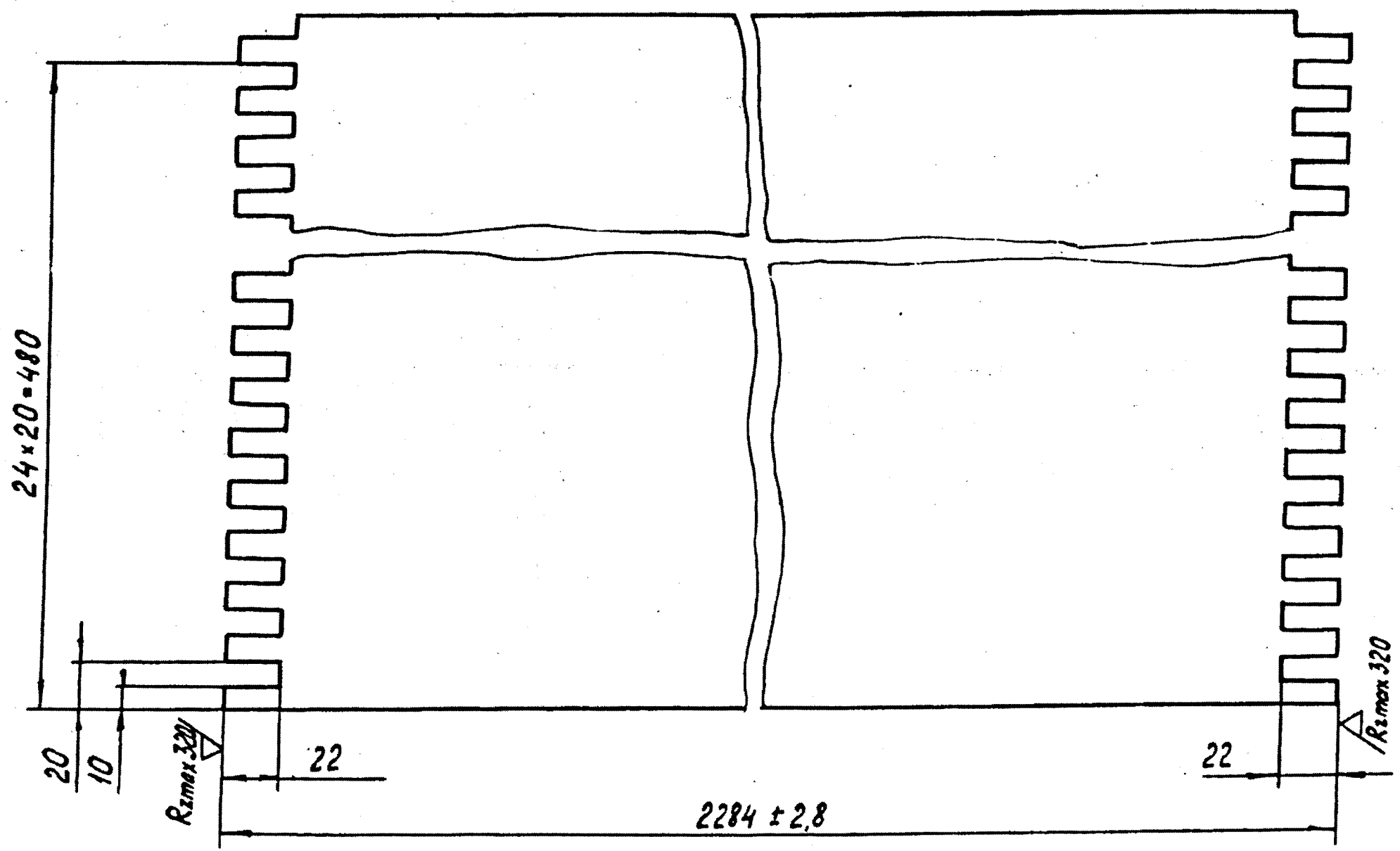

Rz max 800/ (✓)

1. Non-planing of one of the sides with area not more than 40% and depth up to 2 mm is permissible.
2. Join the boards with each other in pile using glue FR -12 TU 6-05-1748-81.
3. Make tolerance dimensions as per js 16 GOST 6449.1-82.

					Ya - AO - 18.001			
					Side plate	Type	Weight	Scale
Amen.	Sheet	Doc.No.	Sign	Date		O <sub>2</sub>	12.500	1:2
Developed by								
Checked by								
Head of Q.C.D								
Approved by								
					Lumber of coniferous type, grade 2 GOST 8486-86		Sheet	Sheets 1

Ya - AO - 18.002

First use

Reference No.

Sign and Date

Duplicate Inv. No

Alternate Inv. No

Sign and Date

Orig. inv. no.

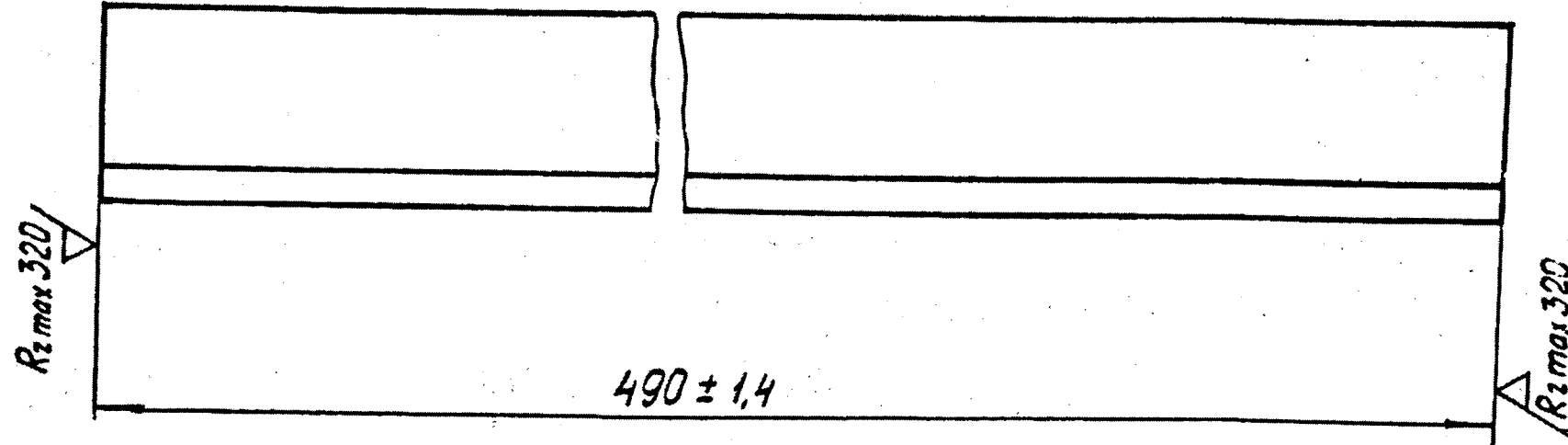

$Rz_{max} 800$  (✓)

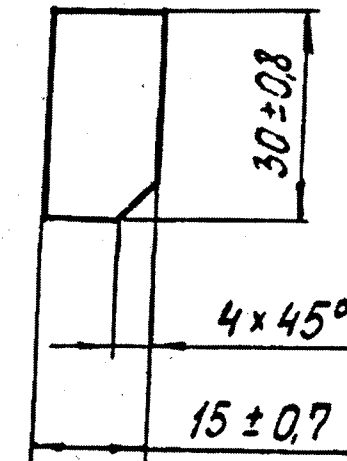

Размеры без допусков выполнять по js16 ГОСТ 6449.1-82.

Make dimensions without tolerances as per js 16 GOST 6449.1-82.

					Ya - AO - 18.002			
Amen.	Sheet	Doc.No.	Sign	Date	Mounting strap	Type	Weight	Scale
							O <sub>2</sub>	0.110
Developed by								
Checked by								
Head of Q.C.D								
Approved by								
					Lumber of coniferous type, grade 2 GOST 8486-86	Sheet		Sheets 1



First use

Reference No.

Sign and Date

Duplicate Inv. No

Alternate Inv. No

Sign and Date

Orig. inv. no.

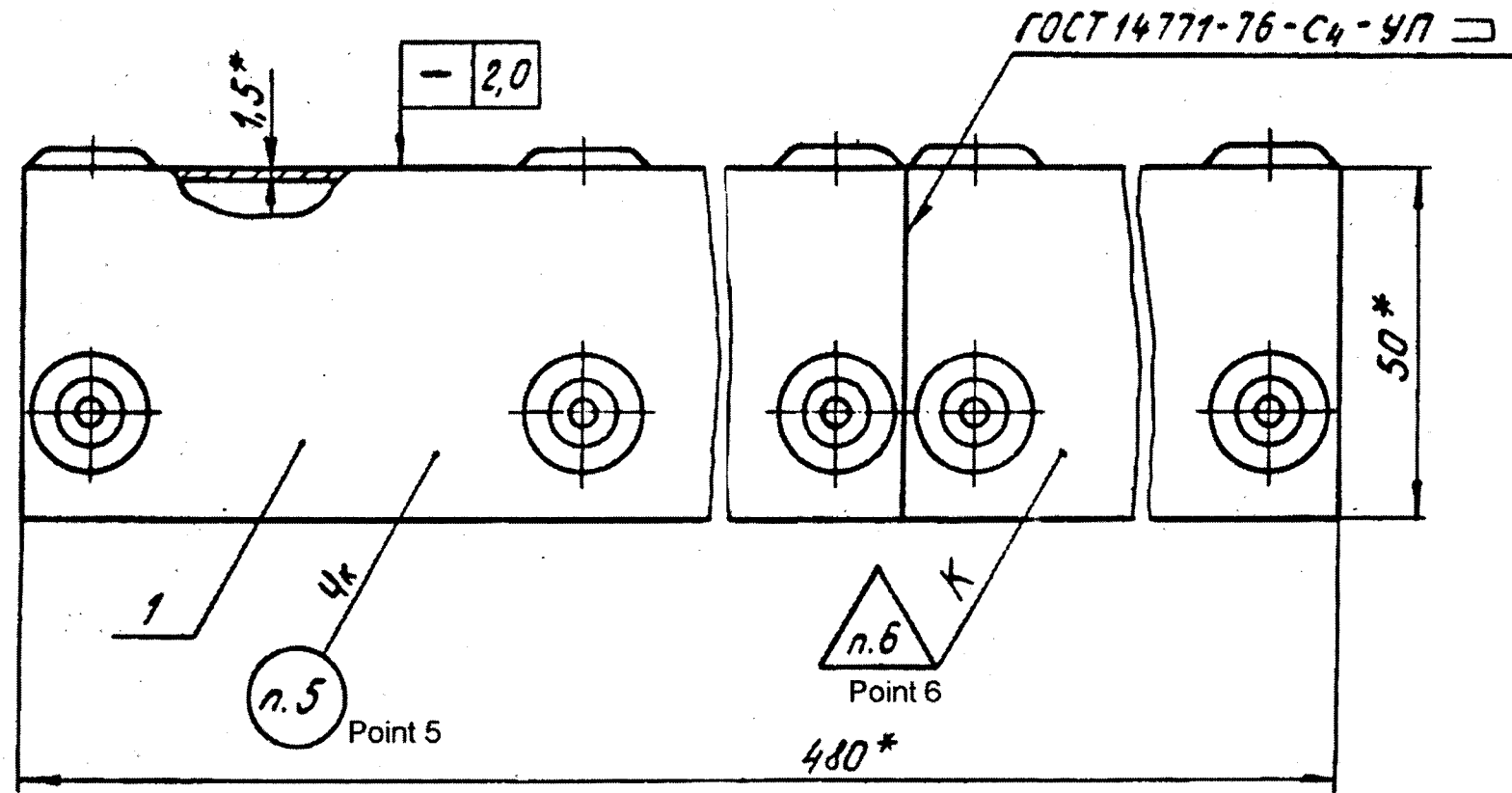

1. Welding with wire 1.2 sv-08 G2S GOST 2246-70. Technical requirements for welding joints as per OST 3-4001-91 , category II.
2. Hand electric arc welding with welding rod UONII 13/45-2.0-3 GOST 9466-75 is permissible.
- 3.\* Reference dimensions.
- 4.Coating : Chem.phos./ impregnation with lacquer BT-987 (1), OMg. Lacquer BT-987 GOST 6244-70.
- 5.Mark in letter size 3-Pr5 GOST 26.008-85.
- 6.Stamp.

					<b>Ya - AO - 18K.100 SB</b>				
					<b>Angle piece assembly drawing</b>	Type		Weight	Scale
						O <sub>2</sub>	0.46		1:1
						Sheet			Sheets 1
Amen.	Sheet	Doc.No.	Sign	Date					
Developed by									
Checked by									
Head of Q.C.D									
Approved by									

First use		Format	Zone	Position	Designation	Nomenclature	Qty.	Remarks	
						<u>Documents</u>			
	A3	/			9-Ya-621.100 SB	Assembly drawing			
Reference No.						<u>Components</u>			
	A3	/	1		9-Ya- 621.023	Box cover	1		
	A3	/	2		9-Ya- 621.004	Key	3		
	A4	/	3		9-Ya- 621.024	Cover strap	2		
						<u>Standard articles</u>			
			4			Wood screw 3-4x20GOST 1145-80	8	Use of	
								1,2 and	
								4 type	
								allowed	
			5			Wood screw 3-4x30GOST 1145-80	9	Use of	
								1,2 and	
								4 type	
								allowed	
Sign and Date									
Dupl. Inv. No.									
Alternate Inv. No.									
Sign and Date									
Orig. Inv. No.									
		Amend.	Sheet	Doc. No.	Sign	Date	<b>9-Ya- 621.100</b>		
		Developed by					Type	Sheet	Sheets
		Checked by					02		1
		Head of Q.C.D							
		Approved by							
							<b>Box cover</b>		

9- Ya-621.100 SB

First use

Reference No.

Sign and Date

Duplicate Inv. No

Alternate Inv. No

Sign and Date

Orig. inv. no.

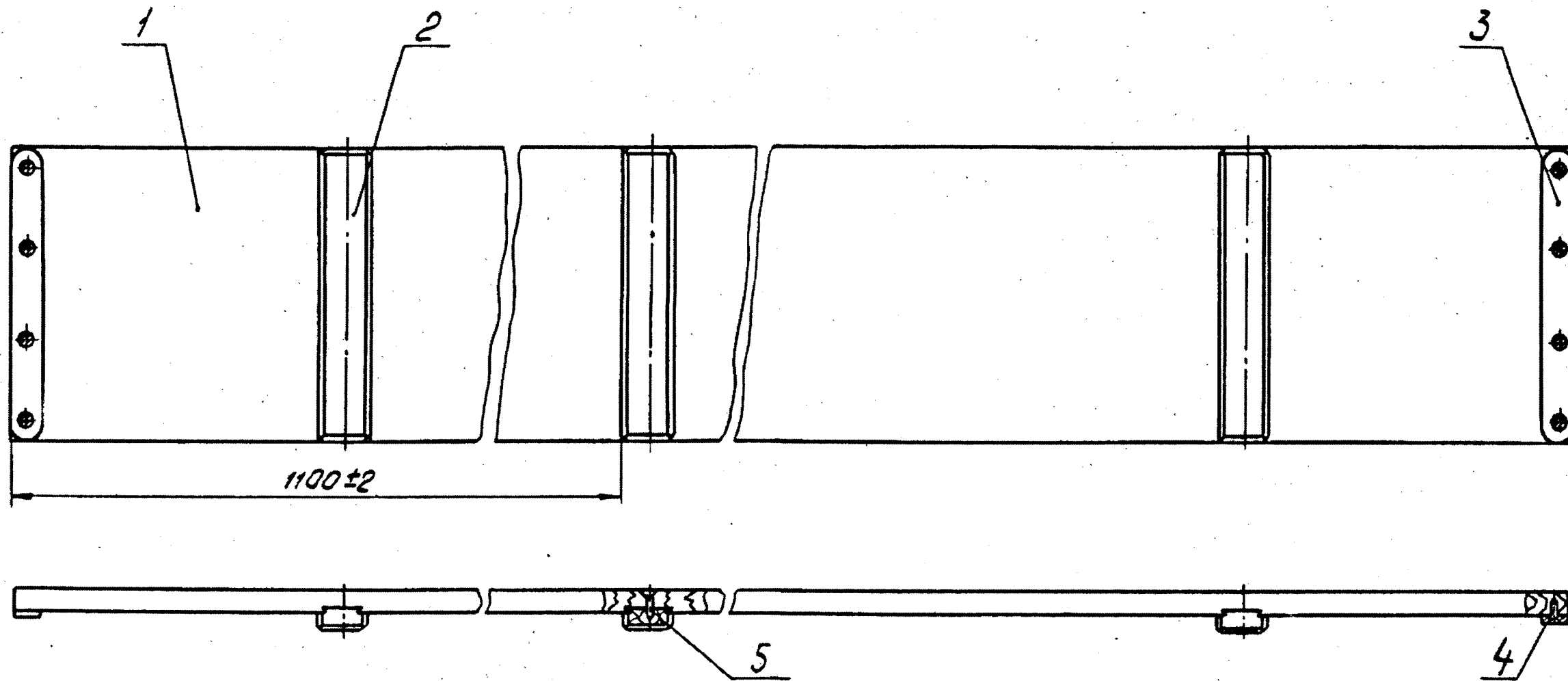

					9- Ya-621.100 SB			
Amend.	Sheet	Doc.No.	Sign	Date	Box cover Assembly drawing	Type	Weight	Scale
Developed by						O <sub>2</sub>	10.800	1:5
Checked by						Sheet	Sheets	1
Head of Q.C.D								
Approved by								

9-Ya-621.004

First use

Reference No.

Sign and Date

Duplicate Inv. No

Alternate Inv. No

Sign and Date

Orig. inv. no.

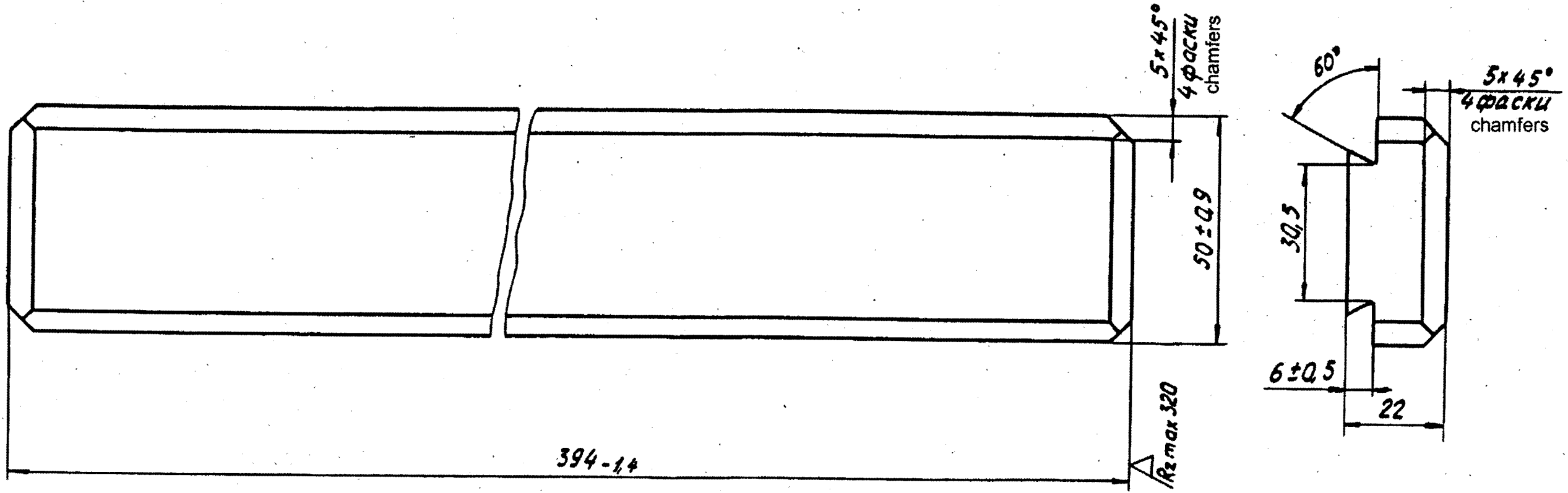

Make dimensions without tolerances as per js16 GOST 6449.1-82.

					9-Ya-621.004			
					Key	Type	Weight	Scale
Amend.	Sheet	Doc.No.	Sign	Date		O <sub>2</sub>	0.212	1:1
Developed by						Sheet	Sheets	1
Checked by					Coniferous lumber, grade 2 GOST 8486-86			
Head of Q.C.D								
Approved by								

9-Ya-621.024

First use				
Approved by shop Reference No.				
Approved KTONI	Sign and Date	Dupl. Inv. No.	Approved TOSb Alternate Inv. No.	Sign and Date
Approved OGMet Orig. Inv. No.	Sign and Date	Dupl. Inv. No.	Approved TOSb Alternate Inv. No.	Sign and Date

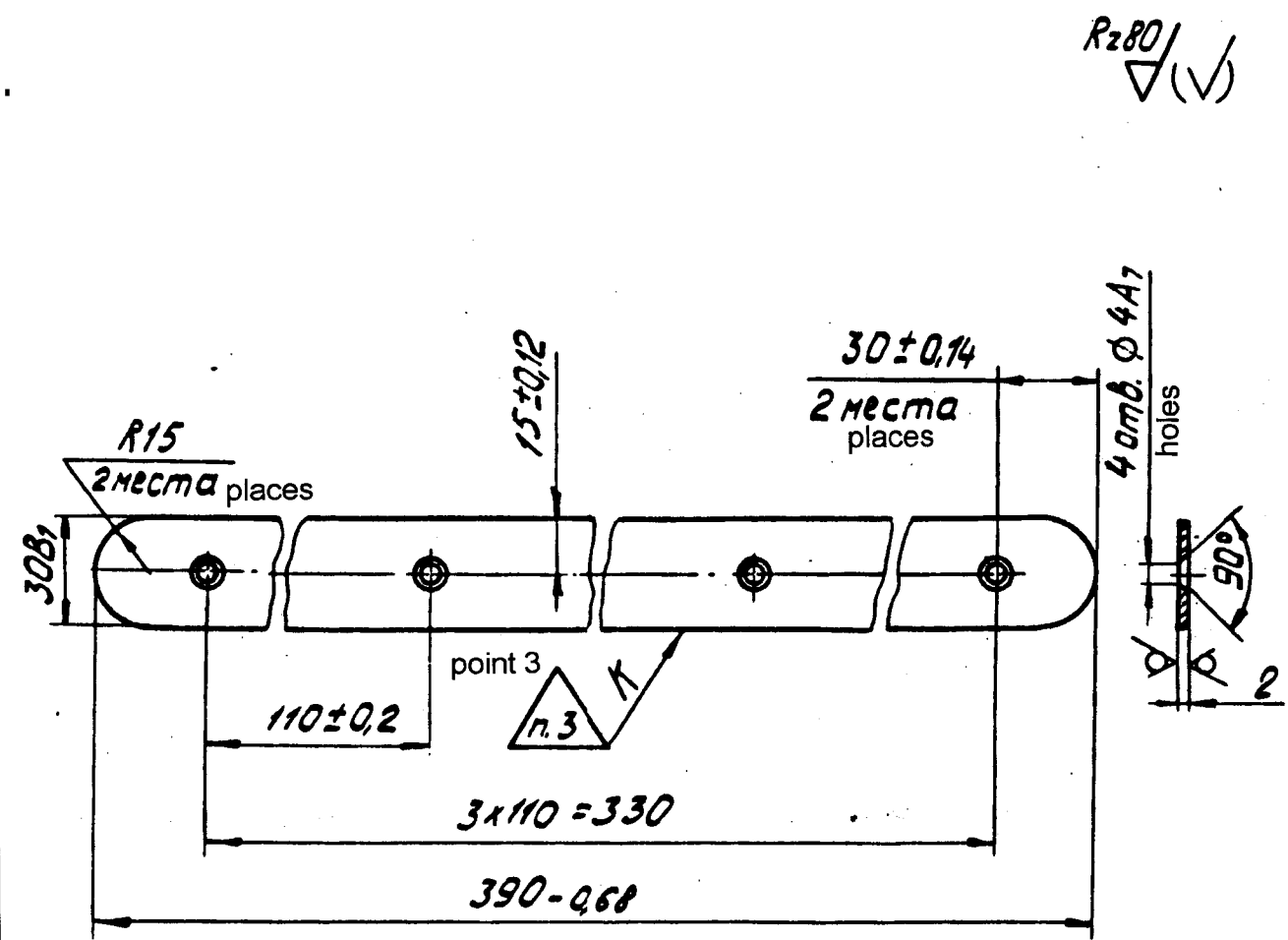

1. Blunt edges R~0.6 mm.
2. Coating: Chem.phos.accel. Oil.
3. Stamp.

9-Ya-621.024

Amend.	Sheet	Doc. No.	Sign	Date	Type	Weight	Scale
					O <sub>2</sub>	0.178	1:2
Cover strap					Sheet	Sheets 1	
Sheet $\frac{B2GOST19903 - 74}{III - 25GOST16523 - 97}$							

Copied by

Format A4

9-Ya-621.023

First use

Reference No.

$Rz_{max} 800$   

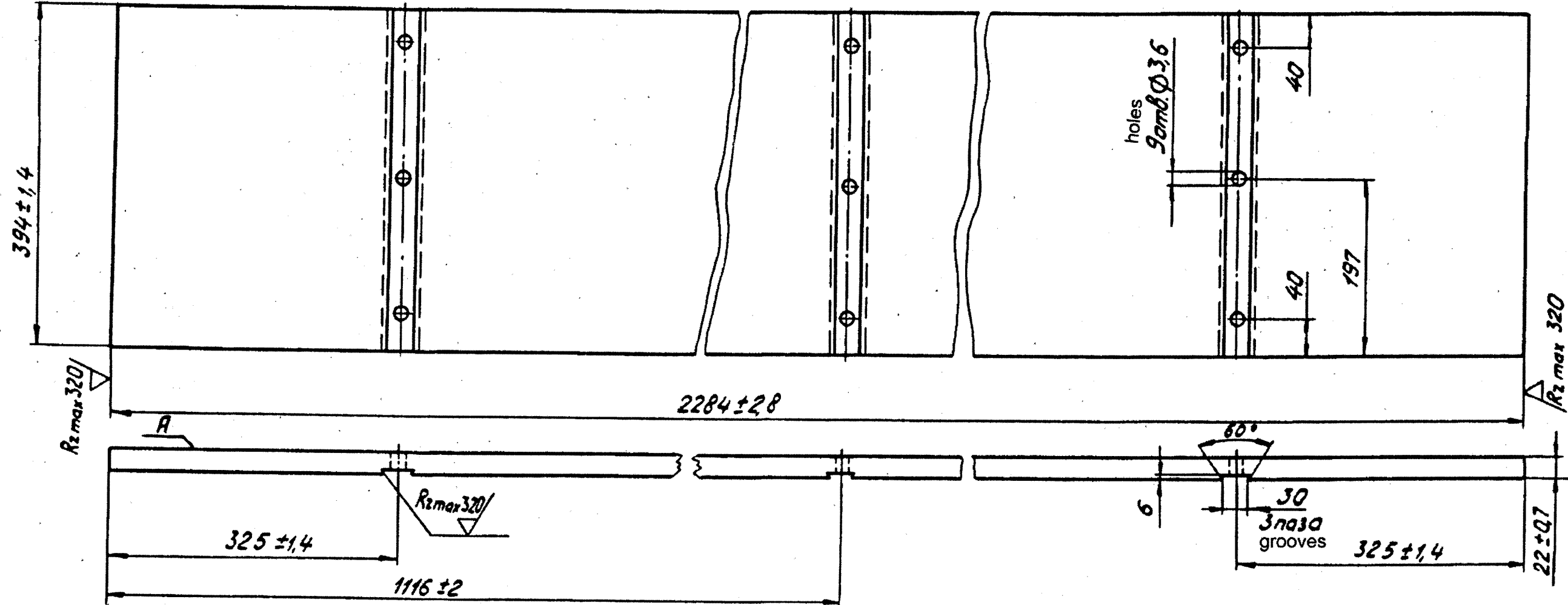

Sign and Date

Duplicate Inv. No

Alternate Inv. No

Sign and Date

Orig. inv. no.

1. Absence of planing of surface A with area not more than 40% and depth up to 2 mm is permissible.
2. Boards are pasted with each other in tongue and groove joint with adhesive FR-12 TU6-05-1748-81.
3. Make dimensions without tolerances as per js16 GOST 6449.1-82.

					9-Ya-621.023			
Amend.	Sheet	Doc.No.	Sign	Date	Box cover	Type	Weight	Scale
Developed by						O <sub>2</sub>	9.790	1:5
Checked by						Sheet	Sheets	1
Head of Q.C.D					Coniferous lumber, grade 2			
Approved by					GOST 8486-86			

First use	Format	Zone	Position	Designation	Nomenclature	Qty.	Remarks	
					<u>Documents</u>			
	A4	/		Ya-AO-18.030SB	Assembly drawing			
Reference No.					<u>Components</u>			
	A3	/	1	Ya-AO-18.017	Upper front pyramid	1		
	W/D	/	2	Ya-AO-18.018	Felt gasket PPrA6-T	1		
					GOST 6308-71-GOST 15159-76			
					L x B = (372x45) h15			
					<u>Standard articles</u>			
			3.		Clamp type III 11x0.9		2 nos.	
					TU 13-317-76		Replacement with pos.4	
			4.		Nails 2 x 20 GOST 4029-63		4 nos.	
							Replacement with pos.3 allowed.	
Sign and Date								
Dupl. Inv. No.								
Alternate Inv. No.								
Sign and Date								
Orig. Inv. No.								
				<b>Ya-AO-18.030</b>				
	Amend.	Sheet	Doc. No.	Sign	Date			
	Developed by					Type	Sheet	Sheets
	Checked by					02		1
	Head of Q.C.D					<b>Upper front pyramid</b>		
	Approved by							



*Rz max 800* (✓)

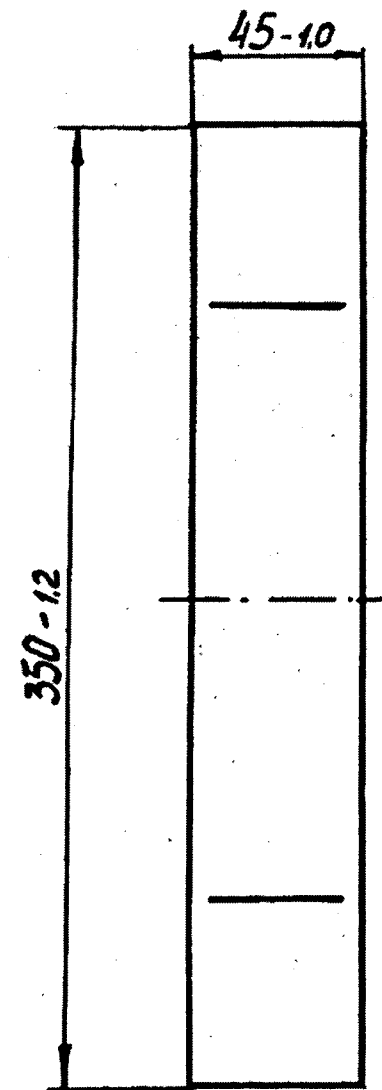
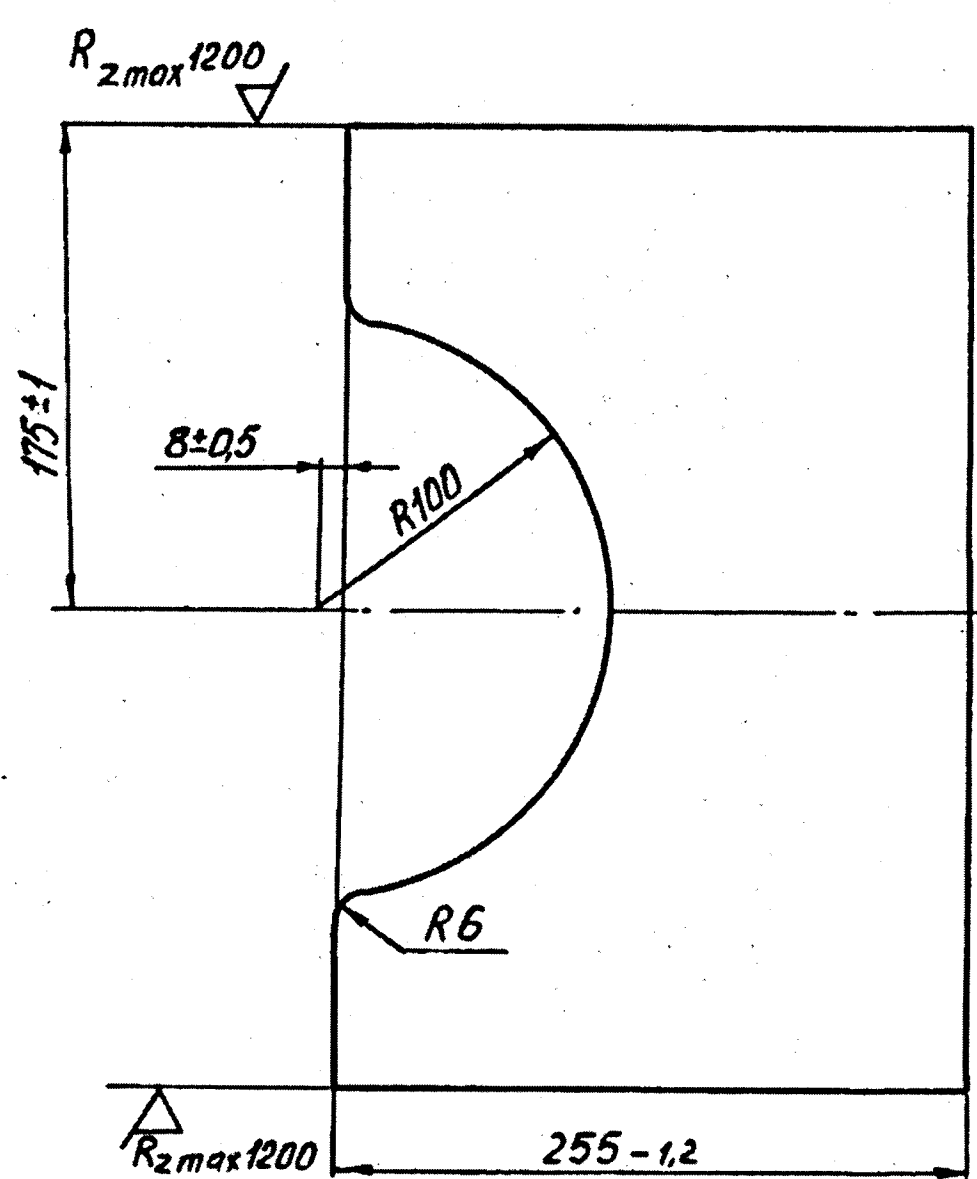

First use  
Reference No.  
Sign and Date  
Duplicate Inv. No  
Alternate Inv. No  
Sign and Date  
Orig. inv. no.

It is permissible to make from two parts with further gluing. Glue FR-12 TU6-05-1748-81.

					Ya - AO - 18.017			
Amen.	Sheet	Doc.No.	Sign	Date	Upper front pyramid	Type	Weight	Scale
Developed by						O <sub>2</sub>	1.760	1:25
Checked by						Sheet		Sheets 1
Head of Q.C.D					Lumber of coniferous type, grade 2 GOST 8486-86			
Approved by								

First use		Format	Zone	Position	Designation	Nomenclature	Qty.	Remarks	
						<u>Documents</u>			
		A4			Ya-AO-18.040SB	Assembly drawing			
Reference No.						<u>Components</u>			
		A3		1	Ya-AO-18.019	Lower front pyramid	1		
		W/D		2	Ya-AO-18.021	Felt gasket PPrA6-T	1		
						GOST 6308-71-GOST 15159-76			
						L x B = (372x45) h15			
						<u>Standard articles</u>			
				3		Clamp type III 11x0.9		2 nos.	
						TU 13-317-76		Replacement with pos.4	
Sign and Date				4		Nails 2 x 20 GOST 4029-63		4 nos.	
Dupl. Inv. No.								Replacement with pos.3 allowed.	
Alternate Inv. No.									
Sign and Date									
Orig. Inv. No.									
		Amend.	Sheet	Doc. No.	Sign	Date	<b>Ya-AO-18.040</b>		
		Developed by					<b>Lower front pyramid</b>	Type Sheet Sheets	
		Checked by						02	1
		Head of Q.C.D							
		Approved by							

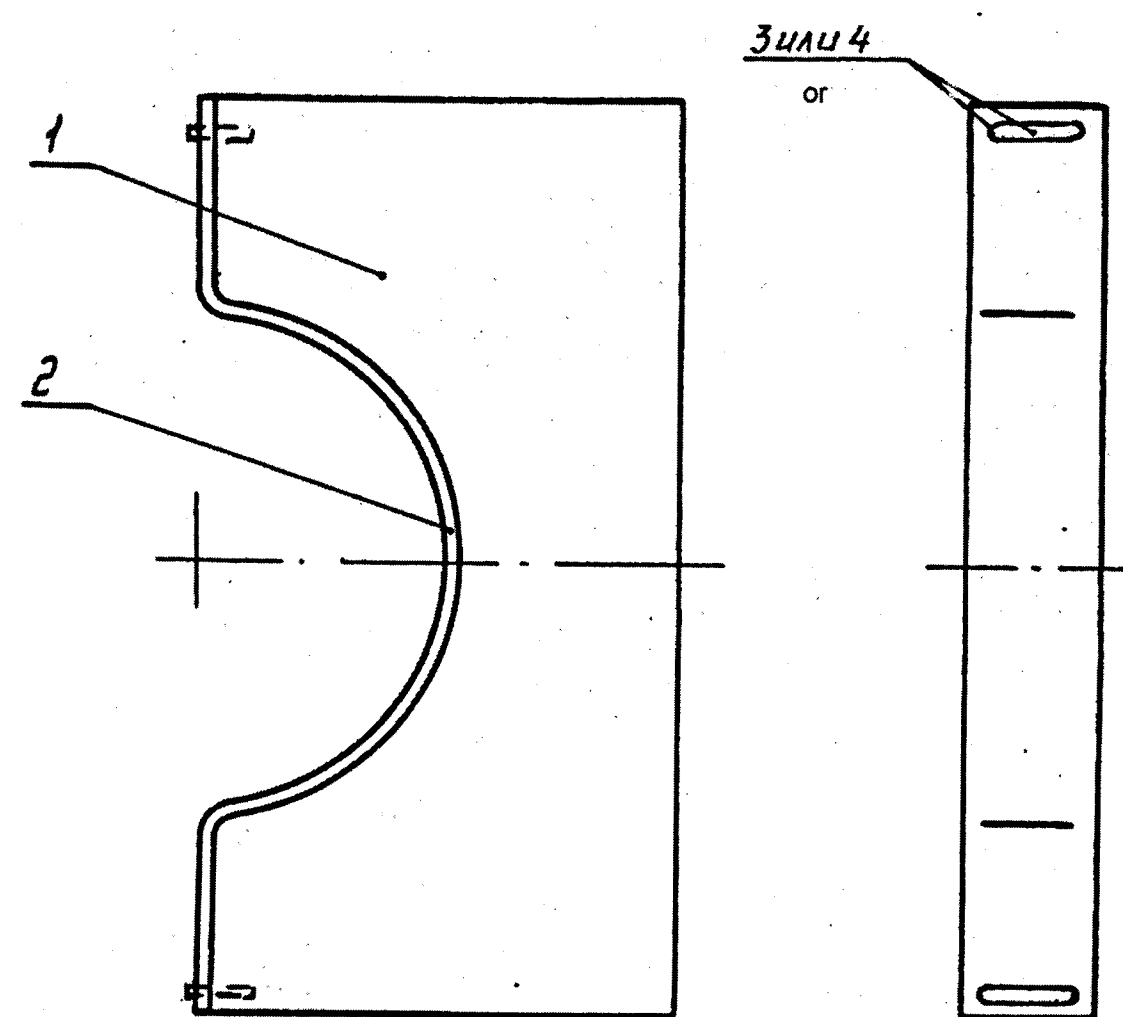
Ya-AO-18.040 SB		First use																																														
Approved by shop	Reference No.																																															
Approved KTONI	Sign and Date																																															
Approved TOsb	Dupl. Inv. No.	<table border="1" style="width: 100%; border-collapse: collapse;"> <tr> <td colspan="5" style="text-align: center;">Ya-AO-18.040 SB</td> </tr> <tr> <td style="width: 10%;"></td> <td style="width: 10%;"></td> <td style="width: 10%;"></td> <td style="width: 10%;"></td> <td style="width: 10%;"></td> </tr> <tr> <td style="text-align: center;">Amend.</td> <td style="text-align: center;">Sheet</td> <td style="text-align: center;">Doc. No.</td> <td style="text-align: center;">Sign</td> <td style="text-align: center;">Date</td> </tr> <tr> <td colspan="5" style="text-align: center;">Developed by</td> </tr> <tr> <td colspan="5" style="text-align: center;">Checked by</td> </tr> <tr> <td colspan="5" style="text-align: center;">Head of Q.C.D</td> </tr> <tr> <td colspan="5" style="text-align: center;">Design bureau chief</td> </tr> <tr> <td colspan="5" style="text-align: center;">Head of Q.C.D</td> </tr> <tr> <td colspan="5" style="text-align: center;">Approved by</td> </tr> </table>		Ya-AO-18.040 SB										Amend.	Sheet	Doc. No.	Sign	Date	Developed by					Checked by					Head of Q.C.D					Design bureau chief					Head of Q.C.D					Approved by				
Ya-AO-18.040 SB																																																
Amend.	Sheet	Doc. No.	Sign	Date																																												
Developed by																																																
Checked by																																																
Head of Q.C.D																																																
Design bureau chief																																																
Head of Q.C.D																																																
Approved by																																																
Approved OGmet	Sign and Date	<table border="1" style="width: 100%; border-collapse: collapse;"> <tr> <td colspan="3" style="text-align: center;">Ya-AO-18.040 SB</td> </tr> <tr> <td style="width: 10%;"></td> <td style="width: 10%;"></td> <td style="width: 10%;"></td> </tr> <tr> <td style="text-align: center;">Type</td> <td style="text-align: center;">Weight</td> <td style="text-align: center;">Scale</td> </tr> <tr> <td style="text-align: center;">O<sub>2</sub></td> <td style="text-align: center;">1.55</td> <td style="text-align: center;">1:2.5</td> </tr> <tr> <td colspan="2" style="text-align: center;">Sheet</td> <td style="text-align: center;">Sheets 1</td> </tr> </table>		Ya-AO-18.040 SB						Type	Weight	Scale	O <sub>2</sub>	1.55	1:2.5	Sheet		Sheets 1																														
Ya-AO-18.040 SB																																																
Type	Weight	Scale																																														
O <sub>2</sub>	1.55	1:2.5																																														
Sheet		Sheets 1																																														

Copied by

Format A4

First use

Reference No.

Sign and Date

Duplicate Inv. No

Alternate Inv. No

Sign and Date

Orig. inv. no.

$Rz_{max} 1200$  (✓)

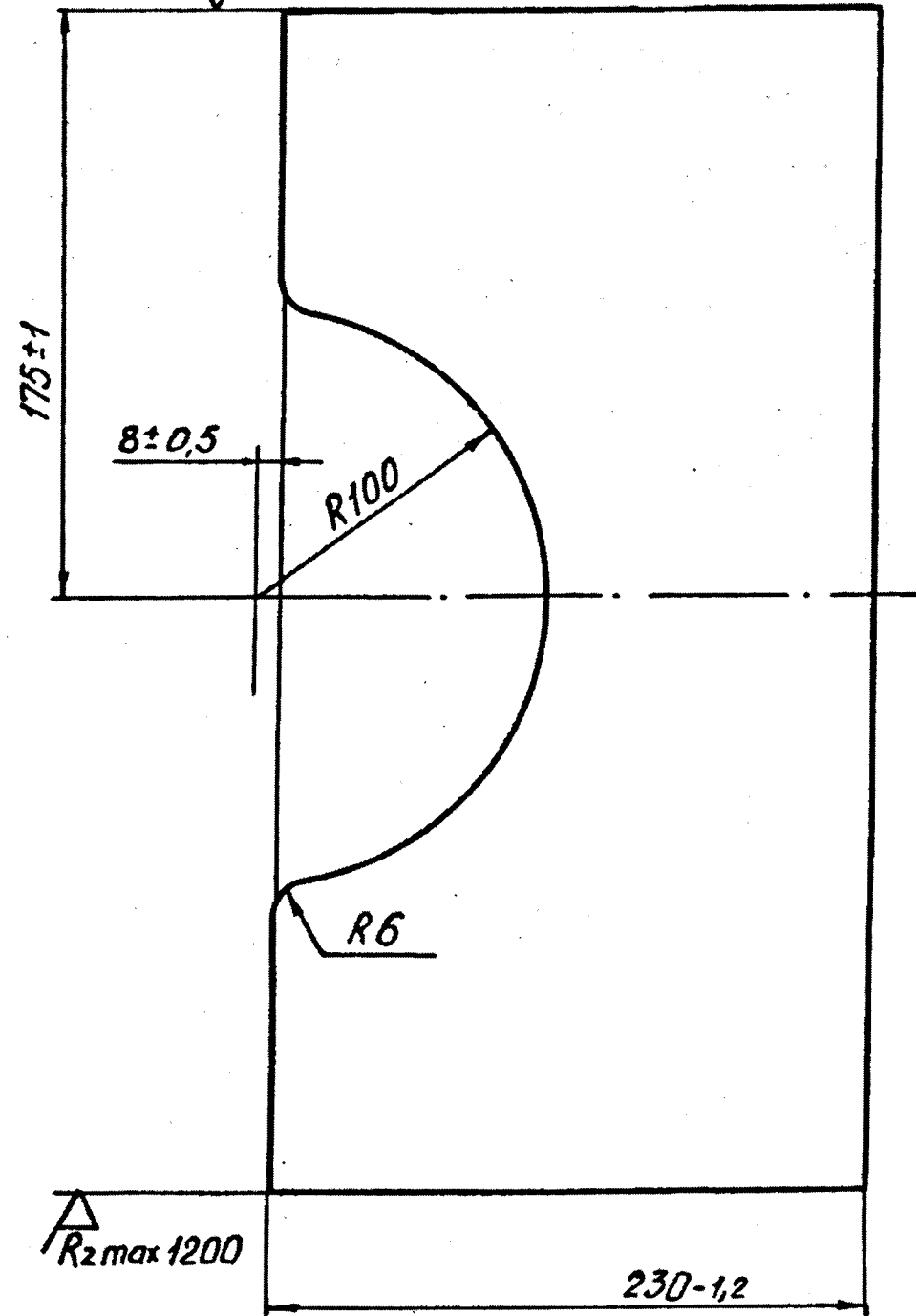

$Rz_{max} 800$  (✓)

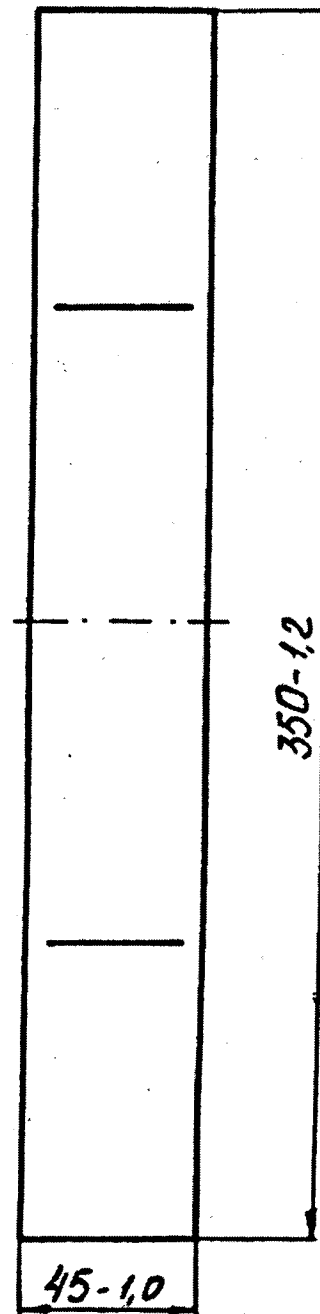

					Ya - AO - 18.019							
					Lower front pyramid	Type		Weight		Scale		
Amen.		Sheet		Doc.No.		Sign		Date		O <sub>2</sub>		
						1.50		1:2				
					Lumber of coniferous type, grade 2 GOST 8486-86		Sheet		Sheets		1	
					Developed by		Checked by		Head of Q.C.D		Approved by	

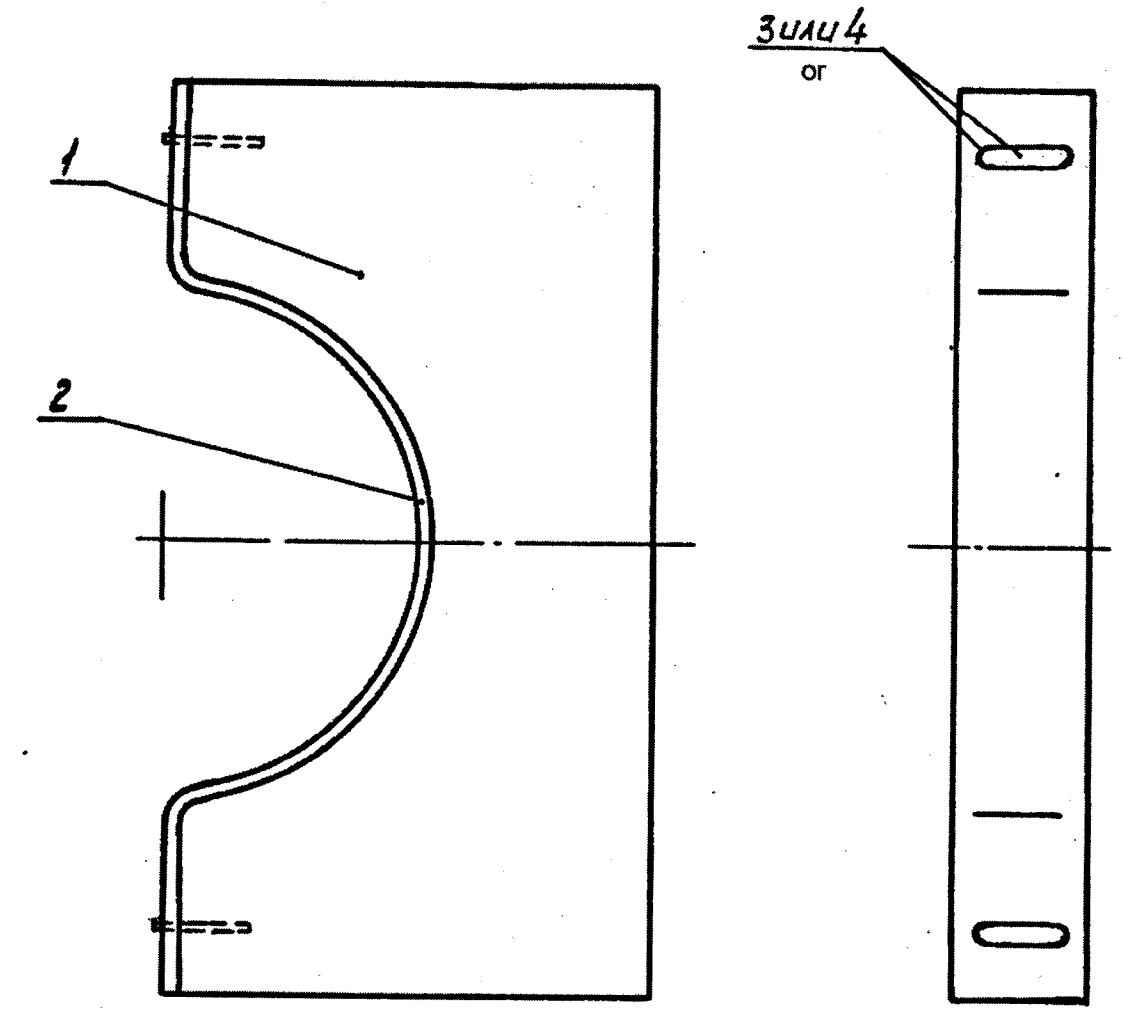

Ya-AO-18.050 SB																																																																							
Approved OGMet	Orig. Inv. No.		Sign and Date		Alternate Inv. No.		Approved TOsb		Approved KTONI																																																														
	Sign and Date		Sign and Date		Dupl. Inv. No.		Sign and Date		Reference No.																																																														
Approved by shop		First use																																																																					
																																																																							
Ya-AO-18.050 SB																																																																							
<table border="1" style="width: 100%; border-collapse: collapse;"> <thead> <tr> <th>Amend.</th> <th>Sheet</th> <th>Doc. No.</th> <th>Sign</th> <th>Date</th> </tr> </thead> <tbody> <tr><td> </td><td> </td><td> </td><td> </td><td> </td></tr> <tr><td> </td><td> </td><td> </td><td> </td><td> </td></tr> <tr><td> </td><td> </td><td> </td><td> </td><td> </td></tr> <tr><td> </td><td> </td><td> </td><td> </td><td> </td></tr> <tr><td> </td><td> </td><td> </td><td> </td><td> </td></tr> <tr><td> </td><td> </td><td> </td><td> </td><td> </td></tr> <tr><td> </td><td> </td><td> </td><td> </td><td> </td></tr> <tr><td> </td><td> </td><td> </td><td> </td><td> </td></tr> <tr><td> </td><td> </td><td> </td><td> </td><td> </td></tr> </tbody> </table>					Amend.	Sheet	Doc. No.	Sign	Date																																														<table border="1" style="width: 100%; border-collapse: collapse;"> <tr> <td colspan="3" style="text-align: center;"><b>Ya-AO-18.050 SB</b></td> </tr> <tr> <td style="text-align: center;">Type</td> <td style="text-align: center;">Weight</td> <td style="text-align: center;">Scale</td> </tr> <tr> <td style="text-align: center;">O<sub>2</sub></td> <td style="text-align: center;">1.5</td> <td style="text-align: center;">1:2.5</td> </tr> <tr> <td colspan="2" style="text-align: center;">Sheet</td> <td style="text-align: center;">Sheets 1</td> </tr> </table>					<b>Ya-AO-18.050 SB</b>			Type	Weight	Scale	O <sub>2</sub>	1.5	1:2.5	Sheet		Sheets 1
Amend.	Sheet	Doc. No.	Sign	Date																																																																			
<b>Ya-AO-18.050 SB</b>																																																																							
Type	Weight	Scale																																																																					
O <sub>2</sub>	1.5	1:2.5																																																																					
Sheet		Sheets 1																																																																					
Developed by																																																																							
Checked by																																																																							
Head of Q.C.D																																																																							
Design bureau chief																																																																							
Head of Q.C.D																																																																							
Approved by																																																																							

Copied by

Format A4

First use

Reference No.

Sign and Date

Duplicate Inv. No

Alternate Inv. No

Sign and Date

Orig. inv. no.

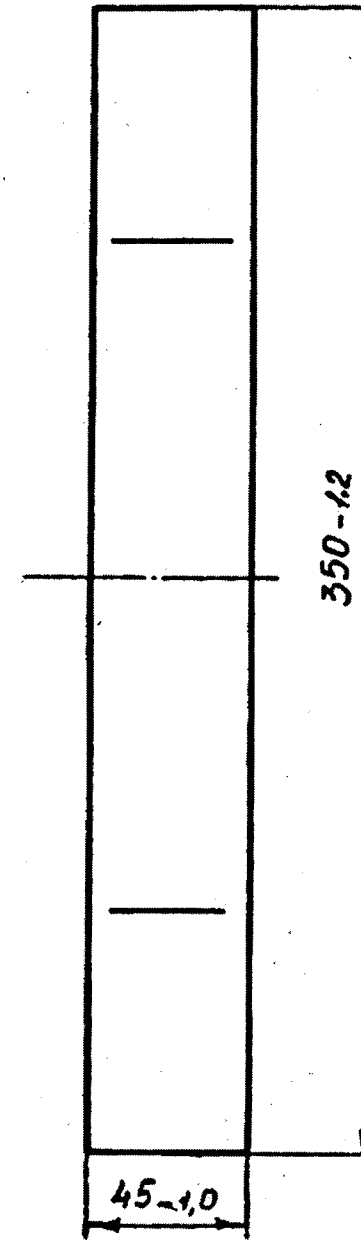
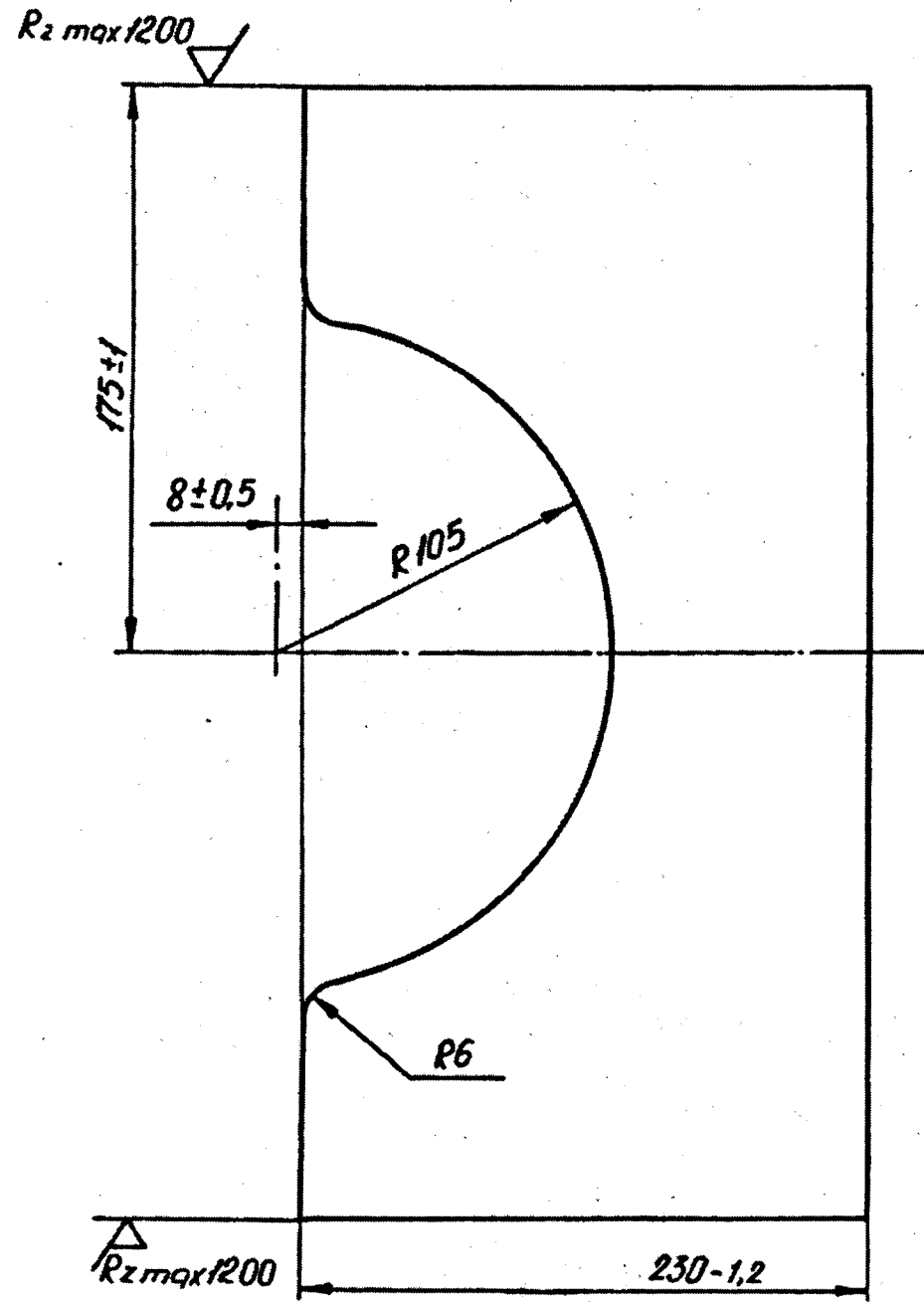

Rz max 800 (✓)

					Ya - AO - 18.022			
Amen.	Sheet	Doc.No.	Sign	Date	Lower middle pyramid	Type	Weight	Scale
Developed by						O <sub>2</sub>	1.460	1:2
Checked by						Sheet	Sheets 1	
Head of Q.C.D					Lumber of coniferous type, grade 2 GOST 8486-86			
Approved by								

First use	Format	Zone	Position	Designation	Nomenclature	Qty.	Remarks	
					<u>Documents</u>			
	A4			Ya-AO-18.060SB	Assembly drawing			
Reference No.					<u>Components</u>			
	A3		1	Ya-AO-18.024	Upper middle pyramid	1		
	W/D		2	Ya-AO-18.025	Felt gasket PPrA6-T GOST 6308-71-GOST 15159-76 L x B = (378x45) h15	1		
					<u>Standard articles</u>			
			3		Clamp type III 11x0.9 TU 13-317-76	2 nos.	Replacement with pos.4	
			4		Nails 2 x 20 GOST 4029-63	4 nos.	Replacement with pos.3 allowed.	
Sign and Date								
Dupl. Inv. No.								
Alternate Inv. No.								
Sign and Date					<b>Ya-AO-18.060</b>			
	Amend.	Sheet	Doc. No.	Sign	Date			
Orig. Inv. No.	Developed by				<b>Upper middle pyramid</b>	Type	Sheet	Sheets
	Checked by					02		1
	Head of Q.C.D							
	Approved by							



*Rz<sub>max</sub> 800* ∇(✓)

*Rz<sub>max</sub> 1200* ∇

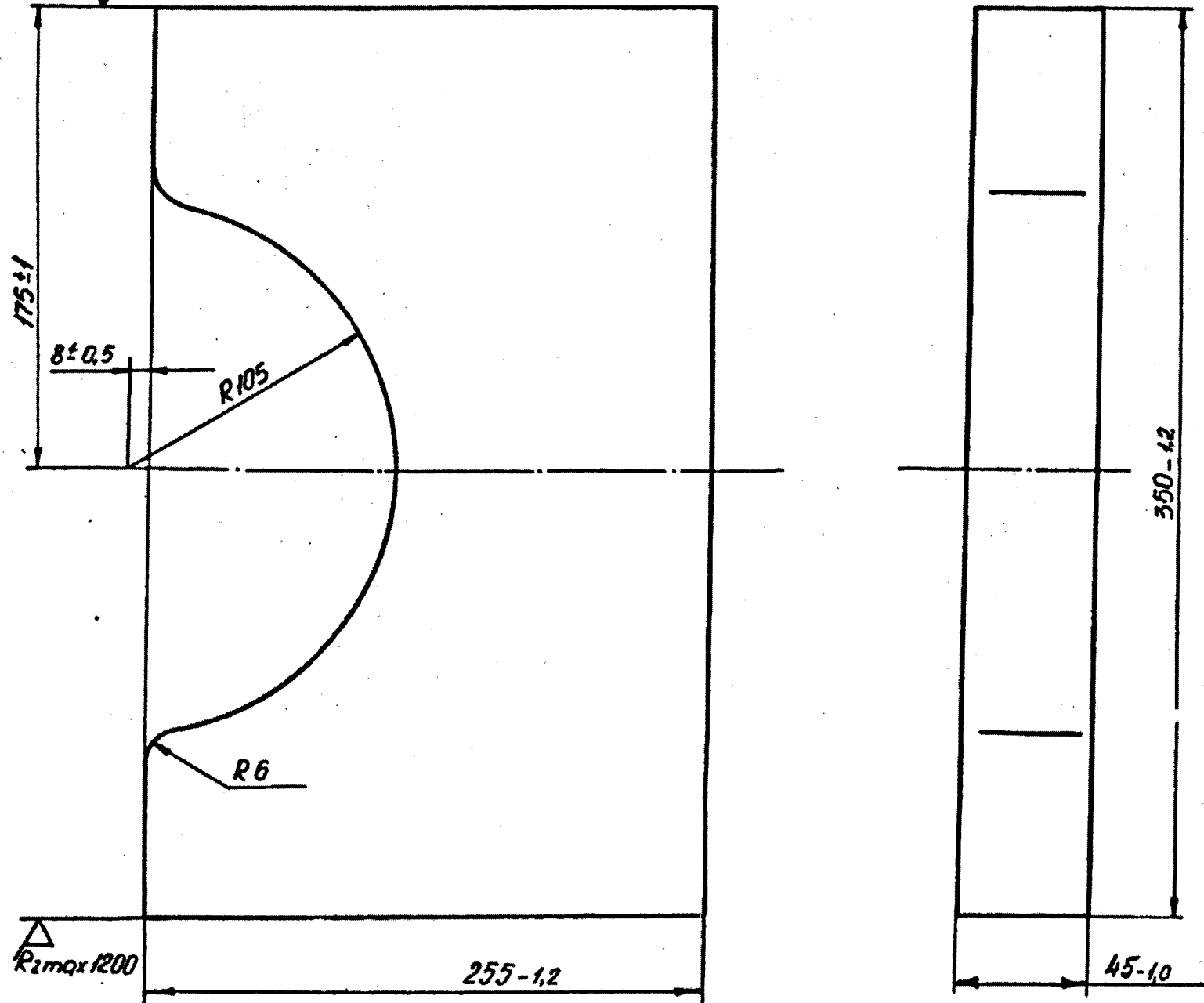

First use

Reference No.

Sign and Date

Duplicate Inv. No

Alternate Inv. No

Sign and Date

Orig. inv. no.

It is permissible to make from two parts with further gluing. Glue FR-12 TU6-05-1748-81.

					Ya - AO - 18.024			
					Upper middle pyramid	Type	Weight	Scale
						O <sub>2</sub>	1.660	1:2
					Sheet		Sheets 1	
					Lumber of coniferous type, grade 2 GOST 8486-86			
Amen.	Sheet	Doc.No.	Sign	Date				
Developed by								
Checked by								
Head of Q.C.D								
Approved by								

First use	Format	Zone	Position	Designation	Nomenclature	Qty.	Remarks	
First use					<u>Documents</u>			
	A4	✓		Ya-AO-18.070SB	Assembly drawing			
Reference No.					<u>Components</u>			
	A3	✓	1	Ya-AO-18.026	Upper rear pyramid	1		
	W/D	✓	2	Ya-AO-18.027	Felt gasket PPrA6-T	1		
					GOST 6308-71-GOST 15159-76			
					L x B = (520 x 45) h15			
					<u>Standard articles</u>			
			3		Clamp type III 11x0.9		2 nos.	
					TU 13-317-76		Replacement with pos.4	
			4		Nails 2 x 20 GOST 4029-63		4 nos.	
							Replacement with pos.3 allowed.	
Sign and Date								
Dupl. Inv. No.								
Alternate Inv. No.								
Sign and Date								
Orig. Inv. No.								
				<b>Ya-AO-18.070</b>				
	Amend.	Sheet	Doc. No.	Sign	Date			
	Developed by					Type	Sheet	Sheets
	Checked by					02		1
	Head of Q.C.D							
	Approved by							
						<b>Upper rear pyramid</b>		

Ya-AO-18.070 SB

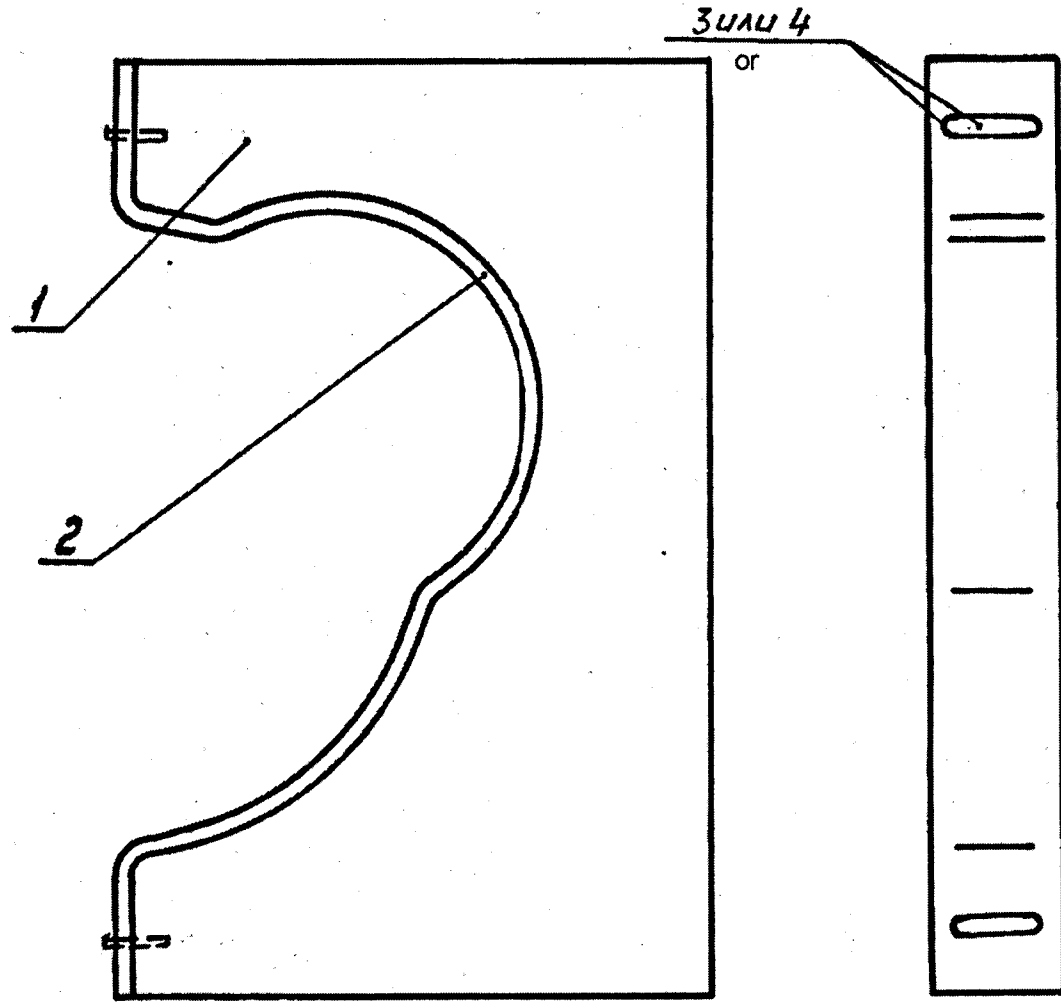

Before nailing on , glue the gasket with nitro glue AK-20 TU 6-10-1293-78.

Approved OGMet		Approved TOSb		Approved KTONI		Approved by shop		First use	
Orig. Inv. No.		Alternate Inv. No.		Sign and Date		Reference No.			
Amend.		Dupl. Inv. No.		Sign and Date					
Sheet									
Doc. No.									
Sign									
Date									
Developed by									
Checked by									
Head of Q.C.D									
Design bureau chief									
Head of Q.C.D									
Approved by									

<b>Ya-AO-18.070 SB</b>			
<b>Upper rear pyramid Assembly drawing</b>	Type	Weight	Scale
	O <sub>2</sub>	1.3	1:2.5
	Sheet	Sheets 1	

Copied by

Format A4

First use

Reference No.

Sign and Date

Duplicate Inv. No

Alternate Inv. No

Sign and Date

Orig. inv. no.

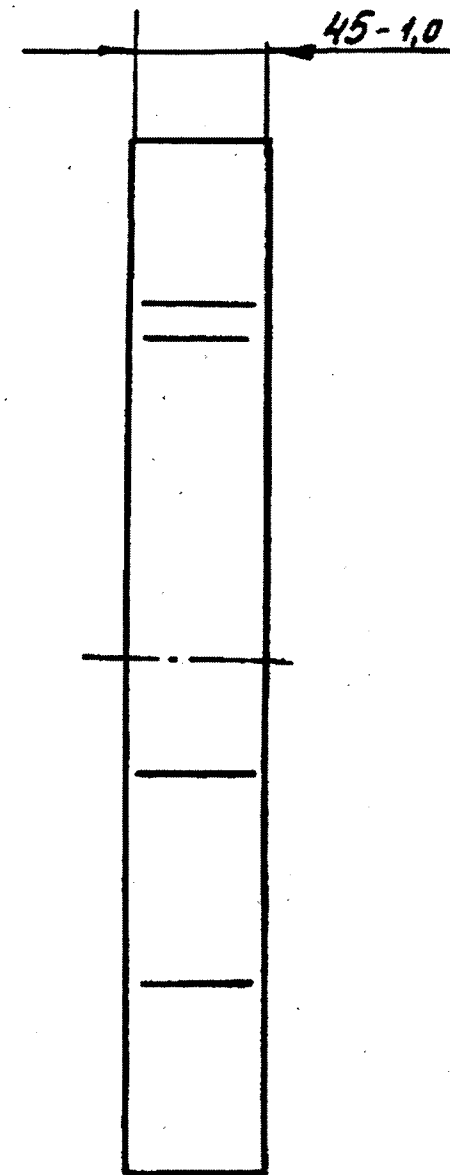
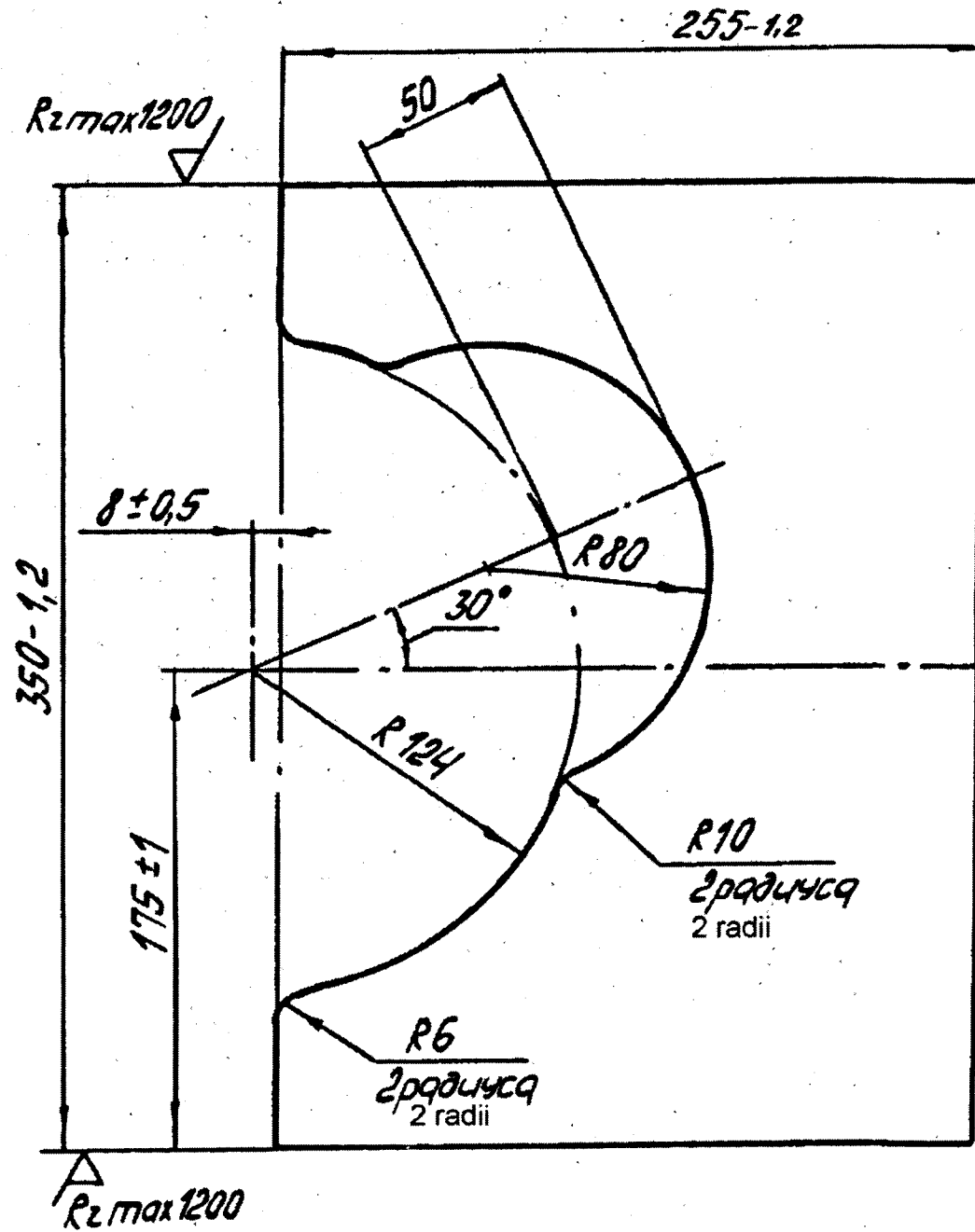

Rzmax800 (✓)

It is permissible to make from two parts with further gluing. Adhesive FR-12 TU6-05-1748-81.

Ya - AO - 18.026

					Ya - AO - 18.026			
					Upper rear pyramid	Type	Weight	Scale
Amen.	Sheet	Doc.No.	Sign	Date		O <sub>2</sub>	1.25	1:2.5
Developed by								
Checked by								
						Sheet	Sheets	1
Head of Q.C.D					Lumber of coniferous type, grade 2 GOST 8486-86			
Approved by								



Ya-AO-18.080 SB		Approved KTONI	Approved by shop	First use
		Sign and Date	Reference No.	
		Sign and Date		
		Dupl. Inv. No.		
		Sign and Date		
		Alternate Inv. No.		
		Sign and Date		
		Approved TOsb		
		Sign and Date		
		Approved OGmet		
		Sign and Date		
		Orig. Inv. No.		

Before nailing on , glue the gasket with nitro glue AK-20 TU 6-10-1293-78.

Ya-AO-18.080 SB				
Amend.	Sheet	Doc. No.	Sign	Date
Developed by				
Checked by				
Head of Q.C.D				
Design bureau chief				
Head of Q.C.D				
Approved by				

Ya-AO-18.080 SB		
Type	Weight	Scale
O <sub>2</sub>	1.3	1:2.5
Sheet		Sheets 1

Copied by

Format A4

First use

Reference No.

Sign and Date

Duplicate Inv. No

Alternate Inv. No

Sign and Date

Orig. inv. no.

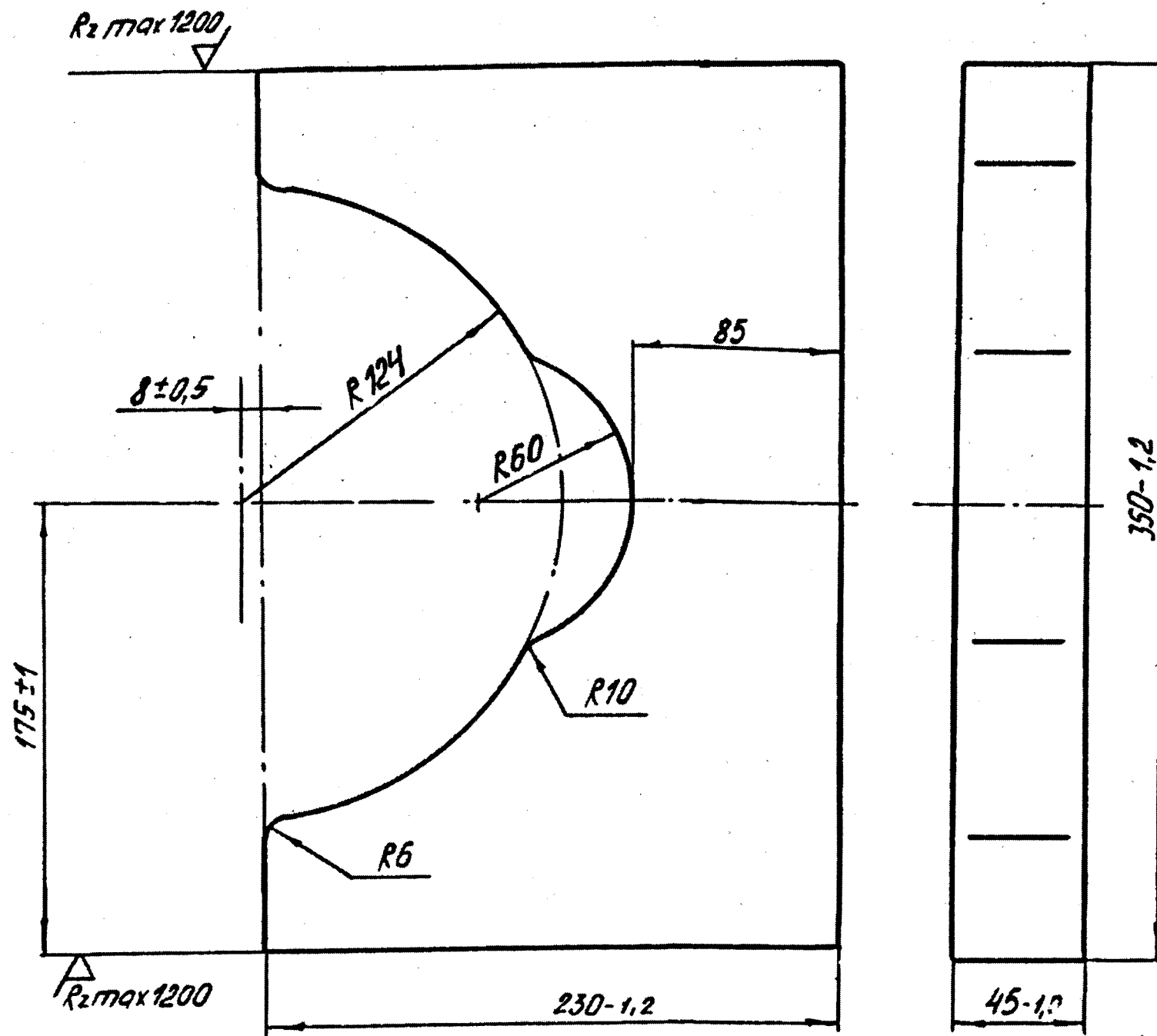

*Rz max 800* (✓)

					Ya - AO - 18.028				
					Lower rear pyramid	Type		Weight	Scale
						O <sub>2</sub>		1.230	1:2
						Sheet		Sheets 1	
					Lumber of coniferous type, grade 2 GOST 8486-86				
Amen.	Sheet	Doc.No.	Sign	Date					
Developed by									
Checked by									
Head of Q.C.D									
Approved by									