

DRG NO. **02040304021500200DA**

GENERAL TOL. : FINE / MEDIUM / COARSE
 CLASS TO IS: 2102

DRG. CONVENTIONS CONFIRM TO INDAN STANDARDS
 DIMENSIONS ARE IN mm UNLESS OTHERWISE STATED.

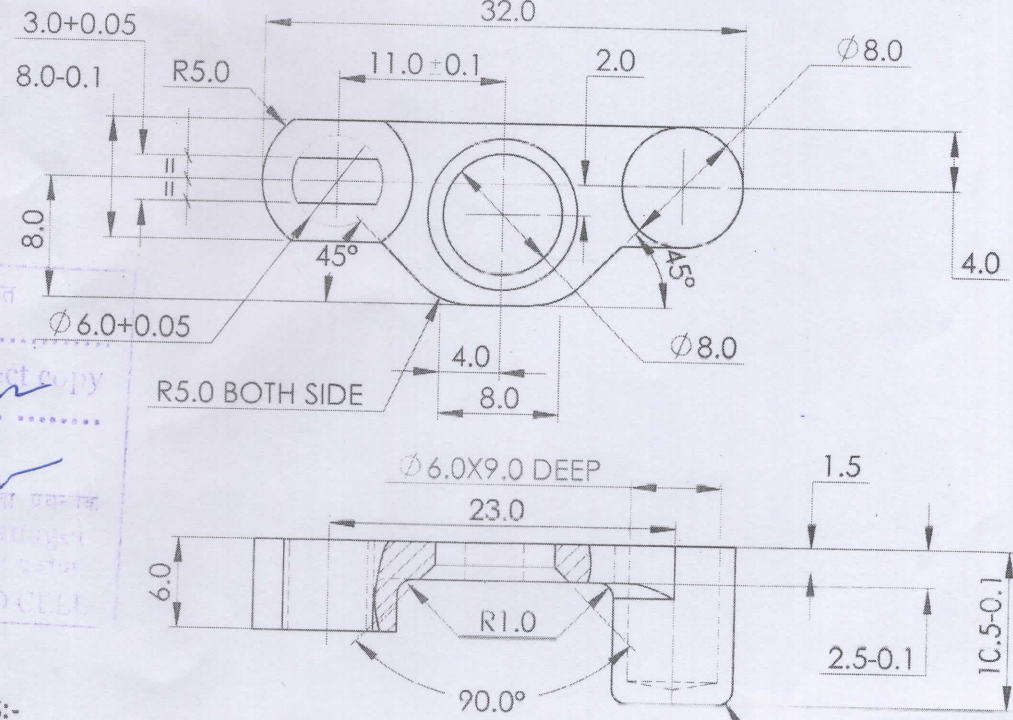

NOTES:-

- 1) REMOVE ALL SHARP EDGES AND BURRS.
- 2) TOLERANCE FOR ANGLES +30° UNLESS OTHER STATED
- 3) HARDNESS : 500 TO 550 H.V.
- 4) HEAT TREATMENT : CASE HARDENED TO A DEPTH OF 0.13 TO 0.26
- 5) IF THE COMPONENT IS TO BE MANUFACTURED THROUGH MIM ROUTE, REFER ARDE SPECN No: DRDO/ARDE/MIM/TSP/051/2019.

अखिल भारतीय प्रमाणित
 प्रमाणिक
 Certified as correct copy
 of drg. on 14/10/22
 क. कविशिला प्रसाद
 Jr. Works Manager
 STANDARD CELL

Sr. No.	DATE	AUTHORITY	BRIEF RECORD	ZONE	CD	GO
DRN: SOURABH	07/03/2019	CHECKED	MATERIAL:			
SIGN: <i>Sourabh</i>			STFFI TO IS:4432-1988, Gd. 13Ni13Cr3			
DATE: 07/03/2019			PROTECTIVE FINISH:			
APPD.	07/03/2019	FOR DIRECTOR	PHOSPHATED TO SPECN. IS:3618-1966, CLASS 'B'			
DATE: 07/03/2019						
SEALED DATE:			TITLE:			
SHEET SIZE: A4	EST. MASS		LEVER STUD CHANGE LEFT			
SCALE: 1:1	6.73 gm					
DESIGN AUTHORITY						
ARDE						
PUNE 411021						
DRG No.	0204	03	04	02	15	002
	IC	SS	S	AA	A	C
JVPC	PART No.	DS CAT No.	AHSP			