

THIS DOCUMENT AND THE INFORMATION CONTAINED IN IT ARE PROPRIETARY AND CONFIDENTIAL TO OFT. NO PERSON OR ENTITY IS ALLOWED TO COPY, REPRINT, REPRODUCE OR PUBLISH ANY PART OF THIS DOCUMENT, NOR DISCLOSE ITS CONTENTS TO OTHERS, NOR MAKE ANY USE OF IT, NOR ALLOW OR ASSIST OTHERS TO MAKE ANY USE OF IT UNLESS BY THE PRIOR WRITTEN EXPRESS AUTHORIZATION OF OFT AND THEN ONLY TO THE EXTENT AUTHORIZED. COPYRIGHT-OFT.

DWG NO Y20105A-00

SHEET REV RECORD
ALL SHEETS ARE THE SAME REVISION

SH 1

1
REVISION RECORD

REV	ECO	DESCRIPTION	DATE	APVD
01		Freeze	10-Jan-18	I. Arbitman
02		Freeze	07-Oct-18	I. Arbitman
03		Freeze	07-Jul-19	I. Arbitman
04		Freeze	30-Jul-19	I. Arbitman
-		Identical To Previous	Released	M. Dafner

NOT FOR PRODUCTION.
FOR ASSEMBLY ON THE PLATFORM ONLY, ACCORDING TO IT'S DIMENSIONS.

27-03-21
[Signature]
[Signature]
[Signature]

B

B

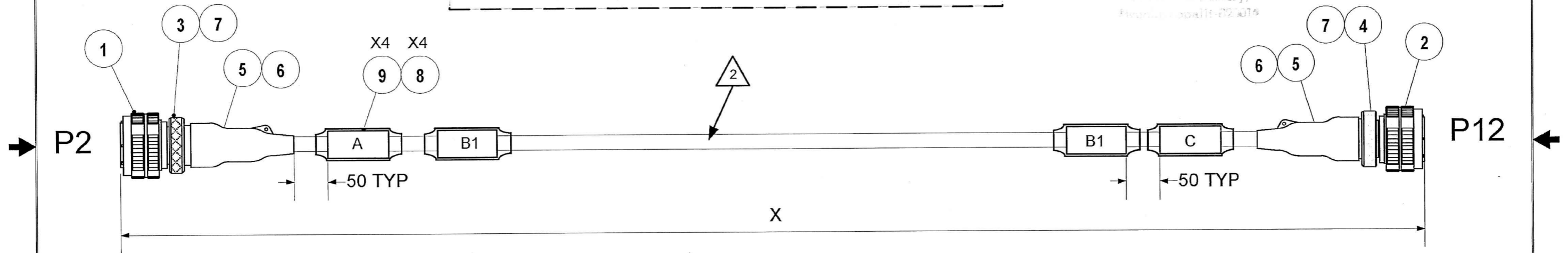

NOTES:

1. MANUFACTURING ACCORDING TO ELBIT 03711A-00

2 FOR REF ONLY. THE CABLE COMES IN DRUM PACKING (RELEVANT DRUMS SIZES CAN BE FOUND IN ELBIT KIT Y30396A-XX FW: 1-3)

A

A

SEE SEPARATE PARTS LIST

STAMPING REQUIREMENTS:

A	B1	C
WNH1A_P2 TO P.S._J2	ELBIT WNH1A Y20105A-XX S/N: ___ MM/YY: ___ CABLE BATCH #: ___	WNH1A_P12 TO PEDESTAL_J12

UNLESS OTHERWISE SPECIFIED		SIGNATURE	DATE	ORDNANCE FACTORY TIRUCHIRAPPALLI	
DIMENSIONS ARE IN MM PER ASME Y14.5M -1994		DRAWN	18/2/21	TITLE	
TOLERANCES LINEAR ANGULAR		CHECKED		CABLE ASSY, WNH1A	
3rd. ANGLE PROJECTION		HOS/DDO	18/2/21	OF: 12.7MM SRCG	
SURFACE TEXTURE IN Micro INCH		OFFICER/PRODN		SIZE	CAGE CODE
▲		OFFICER/QC		B	2291A
PROJECT OFFICER		OFFICER/DDO	18/2/21	DWG NO	Y20105A-00

2

PLM Control

1

SHEET 1 OF 2

2

DWG NO Y20105A-00

SH 2

1

THIS DOCUMENT AND THE INFORMATION CONTAINED IN IT ARE PROPRIETARY AND CONFIDENTIAL TO OFT. NO PERSON OR ENTITY IS ALLOWED TO COPY, REPRINT, REPRODUCE OR PUBLISH ANY PART OF THIS DOCUMENT, NOR DISCLOSE ITS CONTENTS TO OTHERS, NOR MAKE ANY USE OF IT, NOR ALLOW OR ASSIST OTHERS TO MAKE ANY USE OF IT UNLESS BY THE PRIOR WRITTEN EXPRESS AUTHORIZATION OF OFT AND THEN ONLY TO THE EXTENT AUTHORIZED. COPYRIGHT-OFT.

WNH1A

B

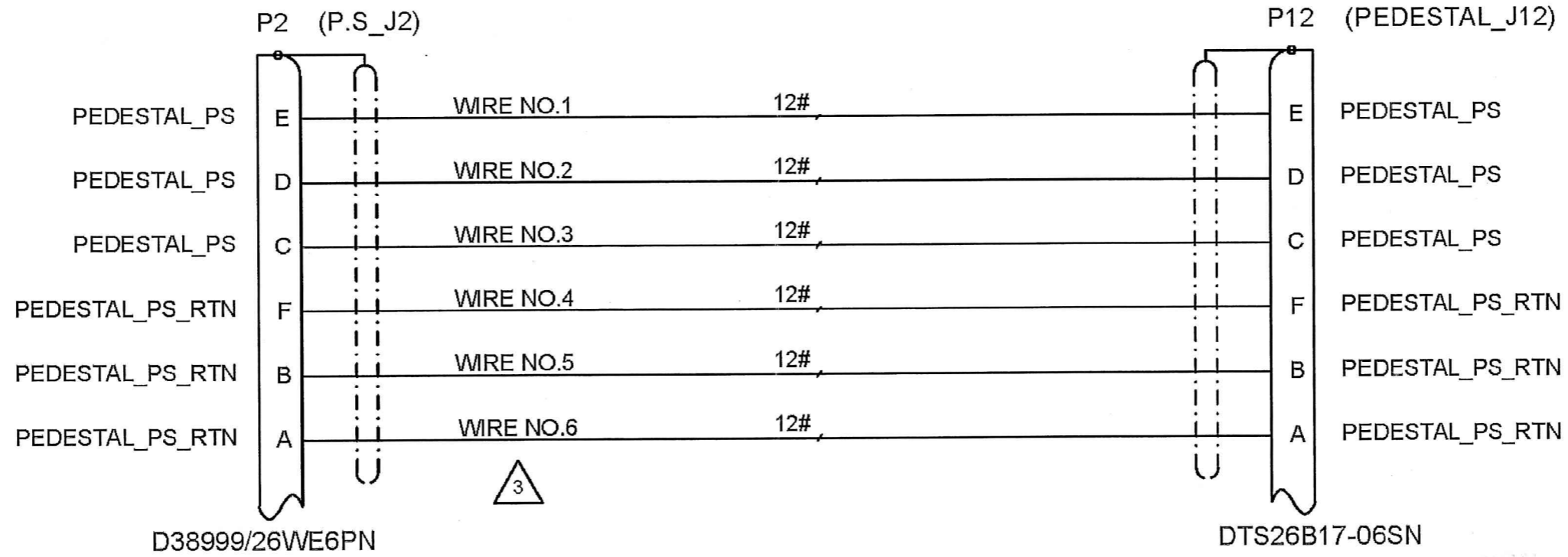

B

A

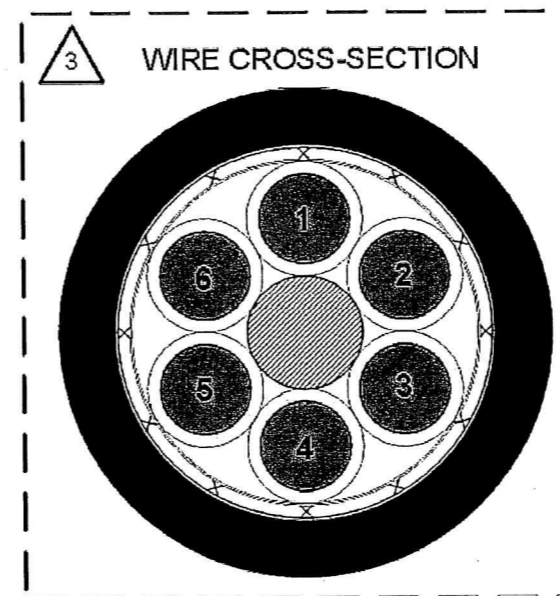

UN COPY...

...STRICT COPY

...DRAWINGS

...27.03.21

...Drawing Office

...Factory,

...62001A

NOTE:

3 WIRE CROSS SECTION AND COMPONENT IDENTIFICATION.

SIZE	CAGE CODE	DWG NO	
B	2291A	Y20105A-00	--
			SHEET 2 OF 2

2

PLM Control

1

OFT

ASSEMBLY PARTS LIST

Assembly Parts List For: Y20105A-00

Rev: -

Status: Released

Description: CABLE ASSY, WNH1A

FN	CMD	PART NUM	ECO	DESCRIPTION	MB	QTY	U/M	REF. DES./REMARKS	MFG. PN /CUSTOMER	LA	LI
1	PO	99931031M		PLUG CIRC 6 P NO.17	P	1	Each	P2	59173-D38999/26WE6PN		
2	PO	00161484N		PLUG CIRC 6 S NO.17 M.BRONZE	P	1.000	EA	P12	44163-DTS26B17-06SN		
3	PO	00031239N		BACKSHELL CONN #17 38999-3,4	P	1	Each	BS P2	45147-E4019S26081S0655		
4	PO	00150386N		BACKSHELL CONN #17 38999-3,4 S	P	1	Each	BS P12	56194-BTH1-17-10-2-Z		
5	VW	20008550L		BOOT,CONN,STRAIGHT (55MMLG)	P	2	Each		58034-202K132-100		
6	YR	00003356N		ADHESIVE EPOXY POLYAMID KIT FO	P	10.000	GM		20012-S1125 KIT-8		
7	PO	99982350M		BAND CLAMP ID1.8 W .24 F/BACKSHEL	P	2	Each	BAND P2,P12	47017-600-052		
8	VW	99941582M		TUBE SHRINK .750/.375 CLR F.R.	P	0.280	MR		58011-M23053/18-209-C		
9	VW	00158728N		ZH MARKER SLEEVE 3/4DIA WHT	P	4	Each		55386-HX-SCE-1K-19.0-50-9		

UN CONTROLLED
27-03-21
[Signature]

THIS DOCUMENT AND THE INFORMATION CONTAINED IN IT ARE PROPRIETARY AND CONFIDENTIAL TO OFT. NO PERSON OR ENTITY IS ALLOWED TO COPY, REPRINT, REPRODUCE OR PUBLISH ANY PART OF THIS DOCUMENT, NOR DISCLOSE ITS CONTENTS TO OTHERS, NOR MAKE ANY USE OF IT, NOR ALLOW OR ASSIST OTHERS TO MAKE ANY USE OF IT UNLESS BY THE PRIOR WRITTEN EXPRESS AUTHORIZATION OF OFT AND THEN ONLY TO THE EXTENT AUTHORIZED. COPYRIGHT-OFT.

DWG NO Y20105A-00

SH 1

SHEET REV RECORD

ALL SHEETS ARE THE SAME REVISION

REVISION RECORD

REV	ECO	DESCRIPTION	DATE	APVD	
01		Freeze	10-Jan-18	I. Arbitman	
02		Freeze	07-Oct-18	I. Arbitman	
03		Freeze	07-Jul-19	I. Arbitman	
04		Freeze	30-Jul-19	I. Arbitman	
-		Identical To Previous	Released	13-Aug-19	M. Dafner

NOT FOR PRODUCTION.
FOR ASSEMBLY ON THE PLATFORM ONLY, ACCORDING TO IT'S DIMENSIONS.

UN CONTROLLED COPY
DATE: 27-03-21
[Signature]
[Title]

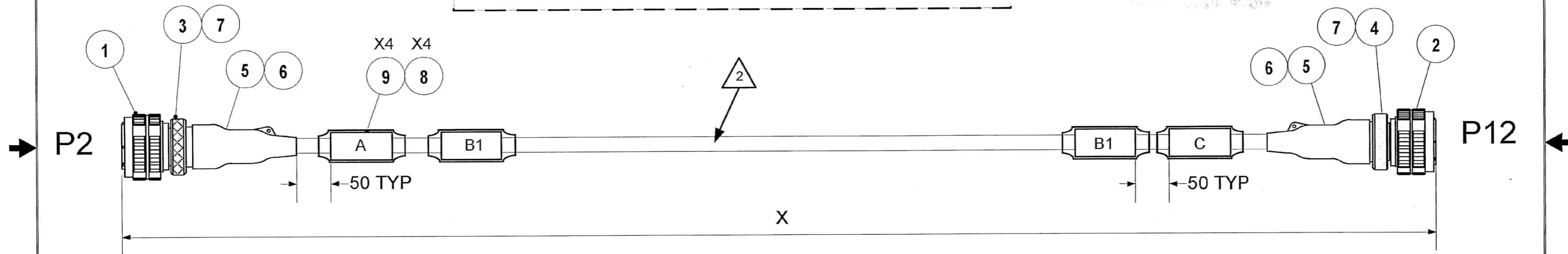

NOTES:

1. MANUFACTURING ACCORDING TO ELBIT 03711A-00

2. FOR REF ONLY. THE CABLE COMES IN DRUM PACKING (RELEVANT DRUMS SIZES CAN BE FOUND IN ELBIT KIT Y30396A-XX FVN: 1-3)

SEE SEPARATE PARTS LIST

STAMPING REQUIREMENTS:

A	B1	C
WNH1A_P2 TO P.S._J2	ELBIT WNH1A Y20105A-XX S/N: ___ MM/YY: ___ CABLE BATCH #: ___	WNH1A_P12 TO PEDESTAL_J12

UNLESS OTHERWISE SPECIFIED		SIGNATURE	DATE	ORDNANCE FACTORY TIRUCHIRAPPALLI	
DIMENSIONS ARE IN MM PER ASME Y14.5M -1994		DRAWN	18/12/21	TITLE	
TOLERANCES LINEAR ANGULAR		CHECKED		CABLE ASSY, WNH1A	
3rd. ANGLE PROJECTION		HOS/DDO	18/12/21	OF: 12.7MM SRCG	
SURFACE TEXTURE IN Micro INCH		OFFICER/PRODN		SIZE	CAGE CODE
PROJECT OFFICER		OFFICER/QC		B	2291A
PLM Control		OFFICER/DDO	18/12/21	DWG NO	Y20105A-00
					--
				SHEET 1 OF 2	

2

1

2

1

2

DWG NO Y20105A-00

SH 2

1

THIS DOCUMENT AND THE INFORMATION CONTAINED IN IT ARE PROPRIETARY AND CONFIDENTIAL TO OFT. NO PERSON OR ENTITY IS ALLOWED TO COPY, REPRINT, REPRODUCE OR PUBLISH ANY PART OF THIS DOCUMENT, NOR DISCLOSE ITS CONTENTS TO OTHERS, NOR MAKE ANY USE OF IT, NOR ALLOW OR ASSIST OTHERS TO MAKE ANY USE OF IT UNLESS BY THE PRIOR WRITTEN EXPRESS AUTHORIZATION OF OFT AND THEN ONLY TO THE EXTENT AUTHORIZED.
 COPYRIGHT-OFT.

WNH1A

B

P2 (P.S_J2)

P12 (PEDESTAL_J12)

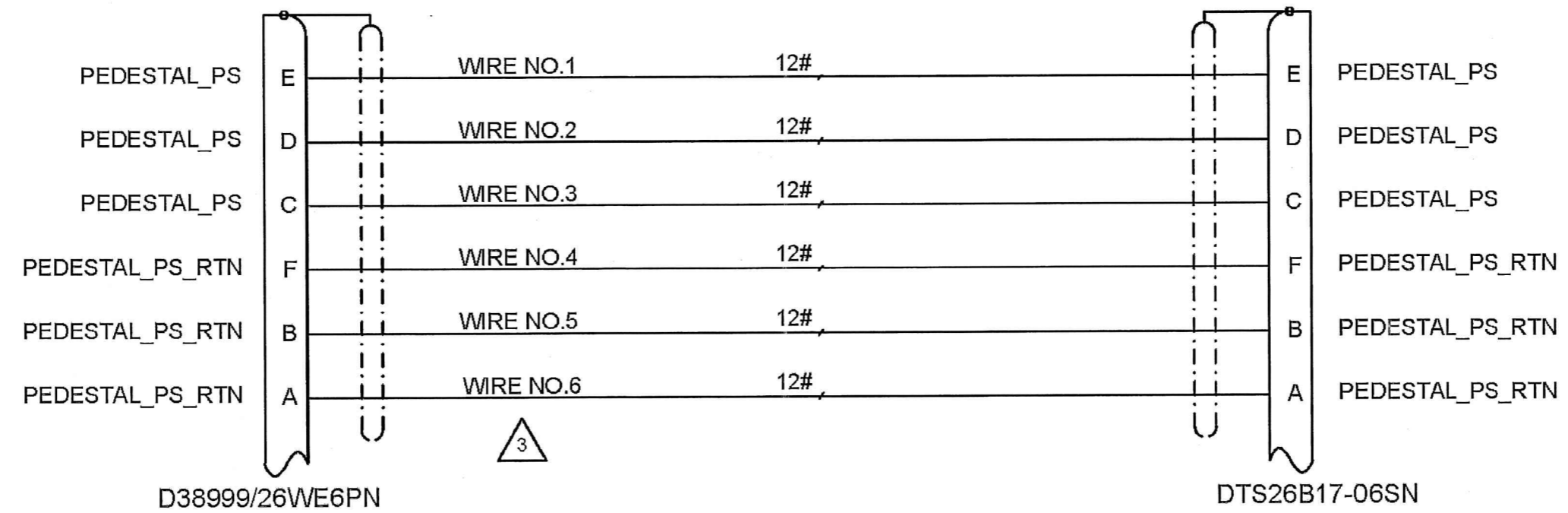

B



A

A

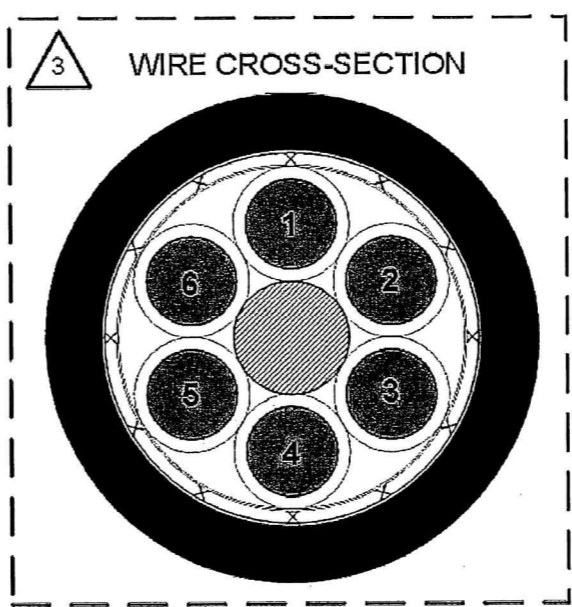

UN COPY
 COPY
 WINGS
 27.03.21
 Drawing Office
 Factory
 620018

NOTE:

 WIRE CROSS SECTION AND COMPONENT IDENTIFICATION.

SIZE	CAGE CODE	DWG NO	
B	2291A	Y20105A-00	--
			SHEET 2 OF 2

2

PLM Control

1

OFT

ASSEMBLY PARTS LIST

Assembly Parts List For: Y20105A-00

Rev: -

Status: Released

Description: CABLE ASSY, WNH1A

FN	CMD	PART NUM	ECO	DESCRIPTION	MB	QTY	U/M	REF. DES./REMARKS	MFG. PN / CUSTOMER	LA	LI
1	PO	99931031M		PLUG CIRC 6 P NO.17	P	1	Each	P2	59173-D38999/26WE6PN		
2	PO	00161484N		PLUG CIRC 6 S NO.17 M.BRONZE	P	1.000	EA	P12	44163-DTS26B17-06SN		
3	PO	00031239N		BACKSHELL CONN #17 38999-3,4	P	1	Each	BS P2	45147-E4019S26081S0655		
4	PO	00150386N		BACKSHELL CONN #17 38999-3,4 S	P	1	Each	BS P12	56194-BTH1-17-10-2-Z		
5	VW	20008550L		BOOT,CONN,STRAIGHT (55MMLG)	P	2	Each		58034-202K132-100		
6	YR	00003356N		ADHESIVE EPOXY POLYAMID KIT FO	P	10.000	GM		20012-S1125 KIT-8		
7	PO	99982350M		BAND CLAMP ID1.8 W.24 F/BACKSHEL	P	2	Each	BAND P2,P12	47017-600-052		
8	VW	99941582M		TUBE SHRINK .750/.375 CLR F.R.	P	0.280	MR		58011-M23053/18-209-C		
9	VW	00158728N		ZH MARKER SLEEVE 3/4DIA WHT	P	4	Each		55386-HX-SCE-1K-19.0-50-9		

UN COPY
27-03-21
[Signature]