

No. OFF	DESCRIPTION	PART No.	MATERIAL	STANDARD	DIMENSIONS	REMARKS																																																	
1	SUPPORT PLATE-III		ALSI 316			**																																																	
<table border="1"> <thead> <tr> <th>GENERAL TOLERANCE</th> <th>ANGULAR DIMENSION</th> <th>No. OFF</th> <th>DRG. No. OF ASSOCIATED PART</th> <th>INDEX</th> <th>DATE</th> <th>NAME</th> </tr> </thead> <tbody> <tr> <td>0-6</td> <td>1:10</td> <td>1-10</td> <td></td> <td></td> <td></td> <td></td> </tr> <tr> <td>6-30</td> <td>1:50</td> <td>10-50</td> <td></td> <td></td> <td></td> <td></td> </tr> <tr> <td>30-125</td> <td>1:20</td> <td>50-100</td> <td></td> <td></td> <td></td> <td></td> </tr> <tr> <td>125-500</td> <td>1:10</td> <td>100-200</td> <td></td> <td></td> <td></td> <td></td> </tr> <tr> <td>500-1000</td> <td>1:5</td> <td></td> <td></td> <td></td> <td></td> <td></td> </tr> <tr> <td>1000-2000</td> <td>1:2.5</td> <td></td> <td></td> <td></td> <td></td> <td></td> </tr> </tbody> </table>							GENERAL TOLERANCE	ANGULAR DIMENSION	No. OFF	DRG. No. OF ASSOCIATED PART	INDEX	DATE	NAME	0-6	1:10	1-10					6-30	1:50	10-50					30-125	1:20	50-100					125-500	1:10	100-200					500-1000	1:5						1000-2000	1:2.5					
GENERAL TOLERANCE	ANGULAR DIMENSION	No. OFF	DRG. No. OF ASSOCIATED PART	INDEX	DATE	NAME																																																	
0-6	1:10	1-10																																																					
6-30	1:50	10-50																																																					
30-125	1:20	50-100																																																					
125-500	1:10	100-200																																																					
500-1000	1:5																																																						
1000-2000	1:2.5																																																						
<table border="1"> <thead> <tr> <th>LINEAR DIMENSIONS</th> <th>VALUE IN "UN"</th> </tr> </thead> <tbody> <tr> <td>0-6</td> <td>0.25</td> </tr> <tr> <td>6-30</td> <td>0.5</td> </tr> <tr> <td>30-125</td> <td>1.0</td> </tr> <tr> <td>125-500</td> <td>1.5</td> </tr> <tr> <td>500-1000</td> <td>2.0</td> </tr> <tr> <td>1000-2000</td> <td>2.5</td> </tr> </tbody> </table>							LINEAR DIMENSIONS	VALUE IN "UN"	0-6	0.25	6-30	0.5	30-125	1.0	125-500	1.5	500-1000	2.0	1000-2000	2.5																																			
LINEAR DIMENSIONS	VALUE IN "UN"																																																						
0-6	0.25																																																						
6-30	0.5																																																						
30-125	1.0																																																						
125-500	1.5																																																						
500-1000	2.0																																																						
1000-2000	2.5																																																						
<table border="1"> <thead> <tr> <th>REPLACED BY</th> <th>CHECKED BY</th> <th>APPROVED BY</th> </tr> </thead> <tbody> <tr> <td></td> <td></td> <td></td> </tr> </tbody> </table>							REPLACED BY	CHECKED BY	APPROVED BY																																														
REPLACED BY	CHECKED BY	APPROVED BY																																																					
<table border="1"> <thead> <tr> <th>SCALE</th> <th>DRAWN</th> <th>CHECKED</th> <th>APPROVED</th> </tr> </thead> <tbody> <tr> <td>1:2.5</td> <td></td> <td></td> <td></td> </tr> </tbody> </table>							SCALE	DRAWN	CHECKED	APPROVED	1:2.5																																												
SCALE	DRAWN	CHECKED	APPROVED																																																				
1:2.5																																																							
<table border="1"> <thead> <tr> <th>DRAWING No.</th> <th>DW-1108-1017-13</th> </tr> </thead> </table>							DRAWING No.	DW-1108-1017-13																																															
DRAWING No.	DW-1108-1017-13																																																						
<table border="1"> <thead> <tr> <th>DESIGN</th> <th>DESIGNER</th> </tr> </thead> <tbody> <tr> <td>Design</td> <td>@ffire</td> </tr> </tbody> </table>							DESIGN	DESIGNER	Design	@ffire																																													
DESIGN	DESIGNER																																																						
Design	@ffire																																																						
<table border="1"> <thead> <tr> <th>MACHINE TOOL PROTOTYPE FACTORY,</th> <th>AMBERNATH</th> </tr> </thead> </table>							MACHINE TOOL PROTOTYPE FACTORY,	AMBERNATH																																															
MACHINE TOOL PROTOTYPE FACTORY,	AMBERNATH																																																						
<p>LAUNCHER ASSY. LR-MR LAUNCHER KAVACH MOD-II</p>																																																							
<p>SUPPORT PLATE-III LAUNCHER ASSY. LR-MR LAUNCHER KAVACH MOD-II</p>																																																							
<p>(G. Ramesh) Commander Chief Inspector of Naval Armament for Controller of Naval Armament Inspection</p>																																																							
<p>MUMBAI INDIA MUMBAI INDIA</p>																																																							

Ø 119 +0.2
+0.1 x 8 OFF

SECTION B-B

** PAINTING

1. PRIMER RED OXIDE TO STANDARD IS:12744 TO BE APPLIED BY FIRM WHO IS SUPPLYING STORE TO MPF AS PER DW-1134

2. PAINTING TO BE DONE AT MPF IN OR DURING ASSEMBLY AS PER DW-1134

NOTE:-

M3-16 HOLES TO BE DONE IN ASSY. FOR LEGEND MOUNTING

THE COPYRIGHT OF THESE DRAWINGS AND ATTACHMENTS TO THE INDIAN ORDNANCE FACTORIES, MINISTRY OF DEFENCE, GOVT. OF INDIA, THEY SHOULD NOT BE COPIED, RE-PRODUCED IN ANY WAY OR THE INFORMATION CONTAINED THEREIN MADE AVAILABLE TO UNAUTHORISED PERSONS WITHOUT THE WRITTEN PERMISSION OF THE DIRECTOR OF ORDNANCE FACTORIES.

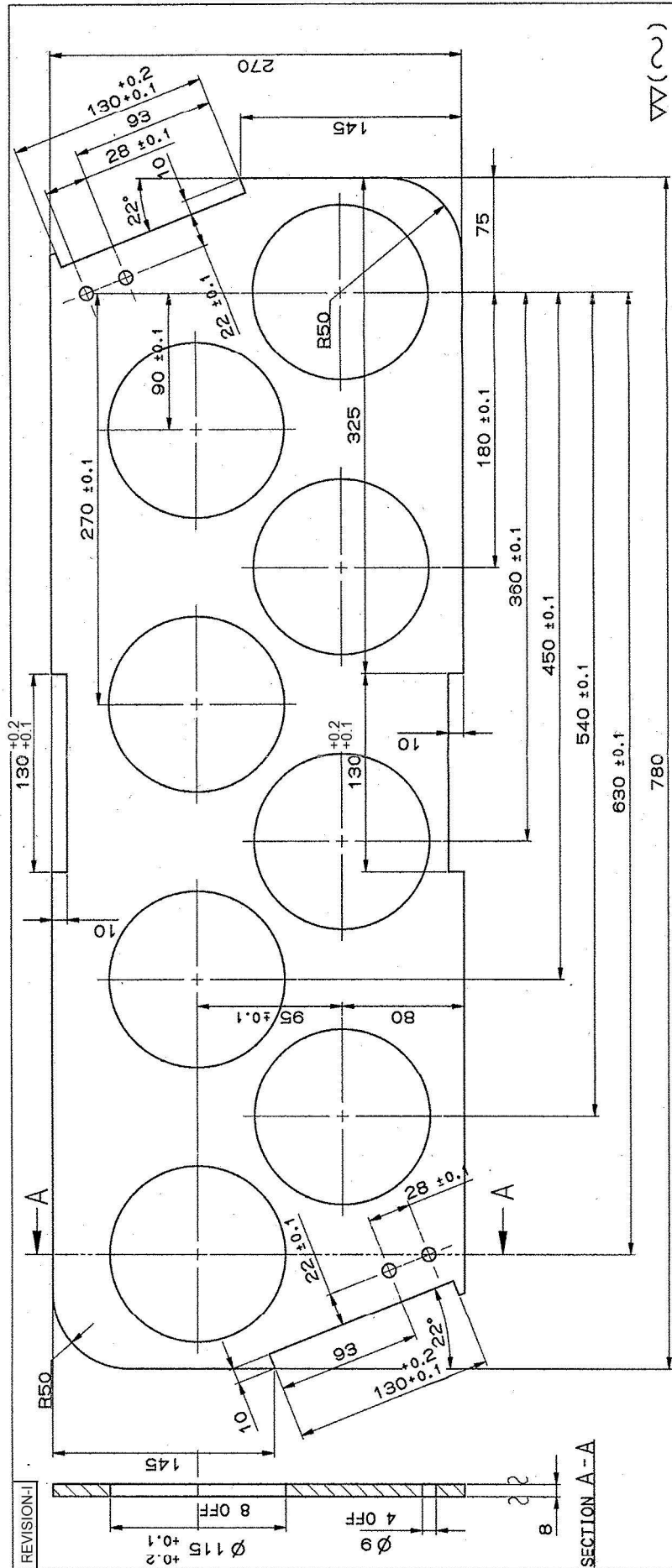

No. OFF	DESCRIPTION	PART No.	MATERIAL	STANDARD	DIMENSIONS	REMARKS
1	SUPPORT PLATE - IV					** *

GENERAL TOLERANCE	ANGULAR DIMENSION	INDEX	DATE	NAME
0-8 ±0.1	1-10 ±1°		18.01.88	W.P.T.
8-30 ±0.2	10-50 ±30'			
30-125 ±0.3	50-100 ±20'			
125-500 ±0.5	100-200 ±1.2			
500-2000 ±1.0				

SCALE	CHECKED	APPROVED
1:2.5	W.P.T.	W.P.T.

REPLACED BY	REPLACED FOR	DRAWING No.
		DW-1108-1018-13

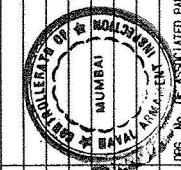

** * * AISI 316

- * PAINTING
- 1. PRIMER RED OXIDE TO STANDARD IS:12744 TO BE APPLIED BY FIRM WHO IS SUPPLYING STORE TO MPFAS PER DW-1134
- 2. PAINTING TO BE DONE AT MPF IN OR DURING ASSEMBLY AS PER DW-1134

THE COPYRIGHT OF THESE DRAWINGS AND ATTACHMENTS TO THE INDIAN ORDNANCE FACTORIES, MINISTRY OF DEFENCE, GOVT. OF INDIA. THEY SHOULD NOT BE COPIED, RE-PRODUCED IN ANY WAY OR THE INFORMATION CONTAINED THEREIN MADE AVAILABLE TO UNAUTHORISED PERSONS WITHOUT THE WRITTEN PERMISSION OF THE DIRECTOR OF ORDNANCE FACTORIES.



NOMINAL SIZE & FIT
DEVIATION

MACHINE TOOL PROTOTYPE FACTORY
AMBERNATH

Design Office

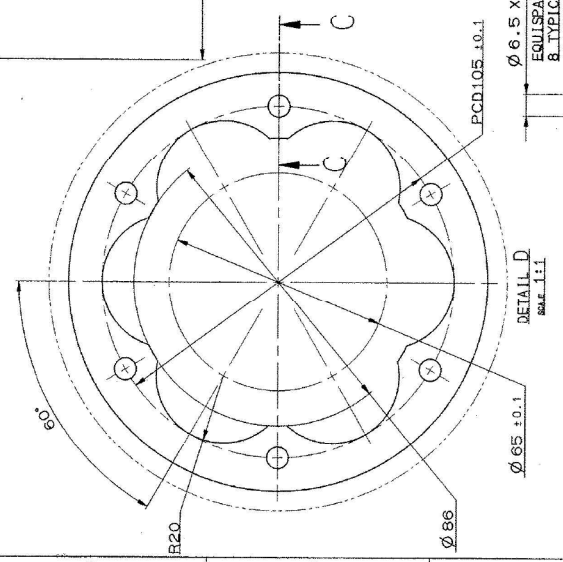
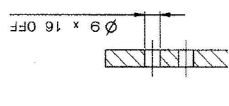
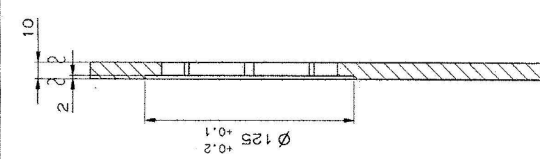
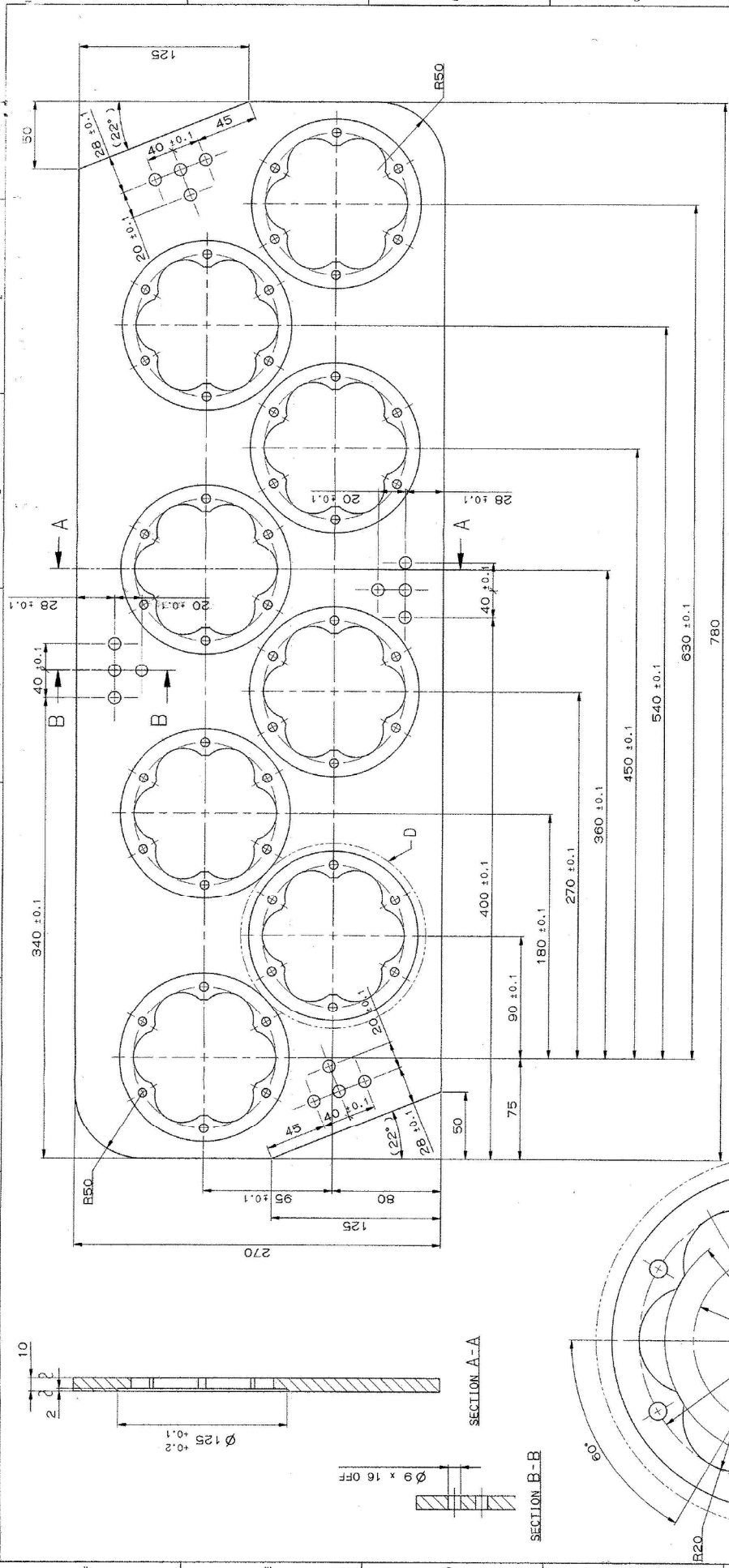

***** PAINTING**

1. PRIMER RED OXIDE TO STANDARD IS:12744 TO BE APPLIED BY FIRM WHO IS SUPPLYING STORE TO MPFAS PER DW-1134
2. PAINTING TO BE DONE AT MPF IN OR DURING ASSEMBLY AS PER DW-1134
3. DO NOT APPLY PRIMER AND PAINT ON THREAD.

NOTE:-

1. Ø10.4 - 8 HOLES TO BE DONE IN ASSY FOR FIRING CONNECTORS MOUNTINGS.
2. M6-4 HOLES TO BE DONE IN ASSY FOR CONNECTOR BOX MOUNTING.
3. M3 - 64 HOLES TO BE DONE IN ASSY FOR LEGEND & CONNECTOR MOUNTING

THE COPYRIGHT OF THESE DRAWINGS AND ATTACHMENTS TO THE INDIAN ORDNANCE FACTORIES, MINISTRY OF DEFENCE, GOVT. OF INDIA THEY REMAIN THE PROPERTY OF THE GOVT. OF INDIA. NO INFORMATION CONTAINED THEREIN SHALL BE MADE AVAILABLE TO ANY PERSONS WITHOUT THE WRITTEN PERMISSION OF THE DIRECTOR OF ORDNANCE FACTORIES.

1 BASE PLATE(R)		S.S. AISI 316		DIMENSIONS		REMARKS	
No. OFF	DESCRIPTION	PART No.	MATERIAL	STANDARD	DIMENSIONS	SCALE	DATE
	GENERAL TOLERANCE					NTS	
LINEAR DIMENSIONS							
0-3	±0.1						
3-30	±0.15						
30-100	±0.2						
100-300	±0.3						
300-500	±0.4						
500-1000	±0.5						
ANGULAR DIMENSIONS							
0-90	±1'						
90-180	±20'						
180-360	±15'						
VALVE IN "m"							
0-25	±0.1						
25-50	±0.15						
50-75	±0.2						
75-100	±0.25						
100-150	±0.3						
150-200	±0.4						
200-300	±0.5						
No. OFF		No. OF ASSOCIATED PART		INDEX		ALTERNATION	
DRAWING No.		DRAWING No.		DRAWING No.		DRAWING No.	
DW-1108-1020-12		DW-1108-1020-12		DW-1108-1020-12		DW-1108-1020-12	



(G Rajmeh)
Commander
Chief Inspector of Naval Armament
for Controller of Naval Armament Inspection

BASE PLATE (R)
LAUNCHER ASSY.
LR-MR LAUNCHER
KAVACH MOD-I-I
MACHINE TOOL PROTOTYPE FACTORY,
AMBARNATH

SCALE	NTS
CHECKED	A-1
APPROVED	A-1
DATE	20/08/17
DRAWN	A-1
REVISOR	A-1
REPLACED	A-1
REPLACED BY	A-1
REPLACED	A-1
REPLACED BY	A-1

REVISION: I

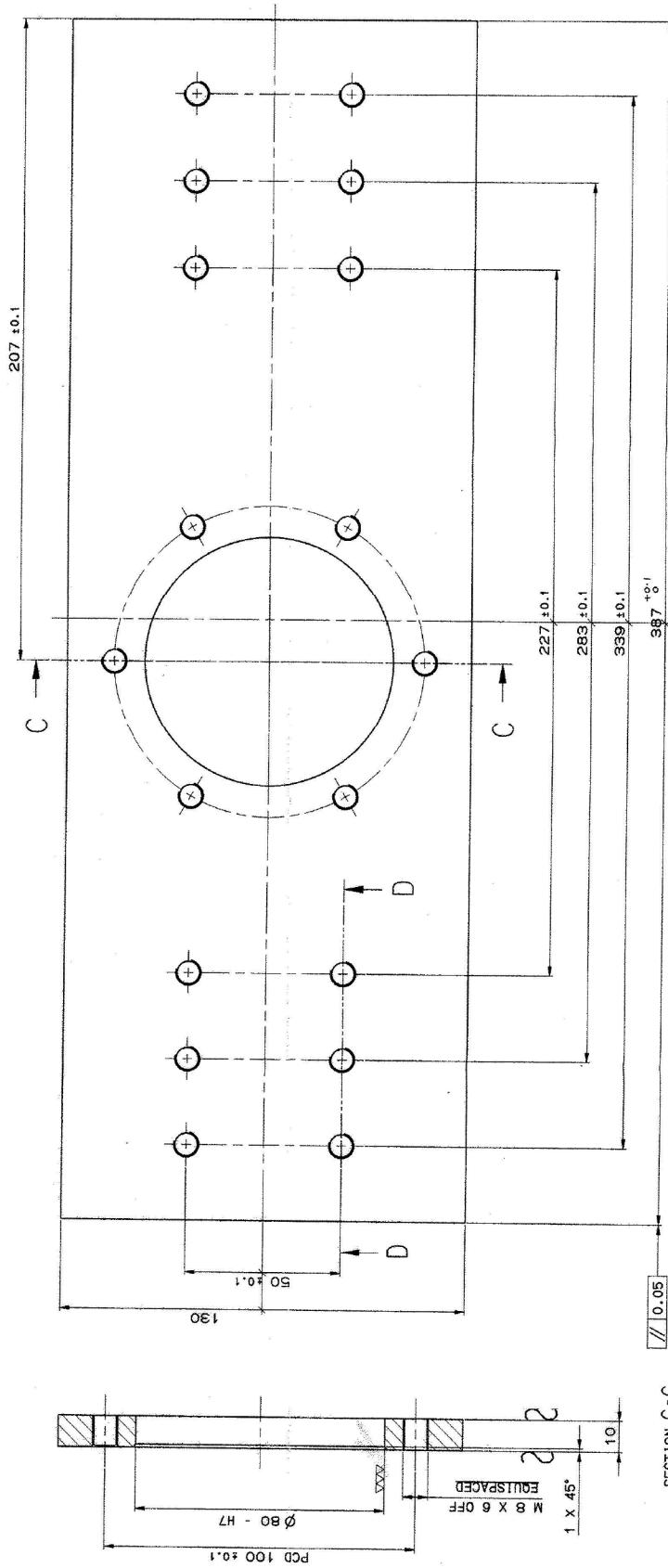

SECTION C-C

SECTION D-D

M 8 X 12 OFF

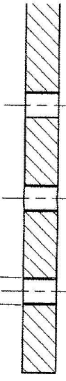

** S.S. AISI 316

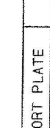

(G. Hamish)
 Commander
 Chief Inspector of Naval Armament
 for Controller of Naval Armament
 INDEX ALLOCATION

4		DESCRIPTION	PART No.	MATERIAL	STANDARD	DIMENSIONS	REMARKS
SIDE SUPPORT PLATE							
LAUNCHER ASSEMBLY							
SRCR LAUNCHER							
KAVACH MOD-II							
MACHINE TOOL PROTOTYPE FACTORY, AMBERNATH							
SCALE 1:1							
DRAWN BY: <i>AK</i>							
CHECKED BY: <i>AK</i>							
APPROVED BY: <i>AK</i>							
DATE: <i>11/11/11</i>							
REPLACED BY: <i>AK</i>							
REPLACED DATE: <i>11/11/11</i>							
DRAWING No. DW-1109-1001-12							

- *** PAINTING
1. PRIMER RED OXIDE TO STANDARD IS: 12744 TO BE APPLIED BY FIRM WHO IS SUPPLYING STORE TO MPF AS PER DW-1134
 2. PAINTING TO BE DONE AT MPF IN OR DURING ASSEMBLY AS PER DW-1134
 3. DO NOT APPLY PRIMER AND PAINT ON THREAD AND BORE SURFACE

THE REVISION OF THESE DRAWINGS AND ATTACHMENTS TO THE INDIAN ORDNANCE FACTORIES, BANGALORE, SHOULD NOT BE COPIED, REPRODUCED, OR TRANSMITTED IN ANY WAY OR BY ANY MEANS WITHOUT THE WRITTEN PERMISSION OF THE DIRECTOR OF ORDNANCE FACTORIES.

10.085
 0.1000
 Ø 80 - H7
 NOMINAL SIZE & FIT DEVIATION

REVISION-I

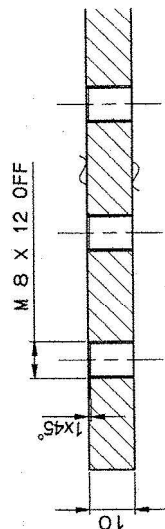
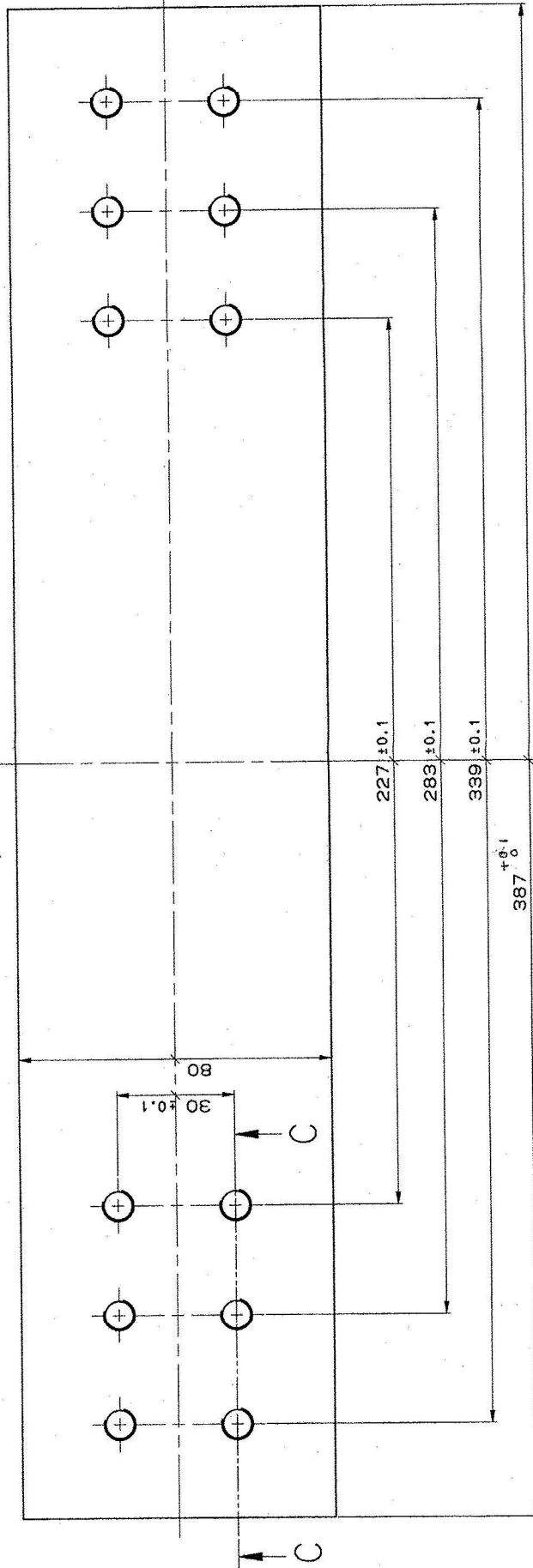

* * * S.S., AISI 316

No. OFF	DESCRIPTION	PART No.	MATERIAL	STANDARD	DIMENSIONS	REMARKS
4	SIDE PLATE		* * *			* * *

GENERAL TOLERANCE	1:10	±1"
LINEAR DIMENSIONS	0-6	±0.1
	6-25	±0.2
	25-50	±0.3
	50-100	±0.5
	100-200	±0.8
	200-315	±1.0
	315-1000	±1.5
	1000-2000	±2.0
ANGULAR DIMENSION	1:10	±1"
	10-50	±30'
	50-100	±20'
	>100	±10'
VALUE IN "um"	~	±25
	∇	±25
	▽	±1.0-1.8
	▽▽	0.025-1.8
	▽▽▽	2.0-125

SCALE	1:1
CHECKED	By
APPROVED	
DATE	07.02.08
NAME	
DRAWN	07.02.08
VJAY	

REPLACED FOR	
REPLACED FOR	
DRAWING No.	DW-1109-1002-13

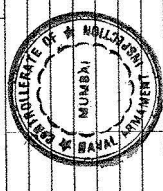

- * * * PAINTING
1. PRIMER RED OXIDE TO STANDARD IS:12744 TO BE APPLIED BY FIRM WHO IS SUPPLYING STORE TO MPF AS PER DW-1134
 2. PAINTING TO BE DONE AT MPF IN OR DURING ASSEMBLY AS PER DW-1134
 3. DO NOT APPLY PRIMER AND PAINT ON THREAD

THE COPYRIGHT OF THESE DRAWINGS AND ATTACHMENTS TO THE INDIAN ORDNANCE FACTORIES, MINISTRY OF DEFENCE, GOVT. OF INDIA THEY SHOULD NOT BE COPIED, RE-PRODUCED IN ANY WAY OR THE INFORMATION CONTAINED THEREIN MADE AVAILABLE TO UNAUTHORISED PERSONS WITHOUT THE WRITTEN PERMISSION OF THE DIRECTOR OF ORDNANCE FACTORIES.

NOMINAL SIZE & FIT
DEVIATION

MACHINE TOOL PROTOTYPE FACTORY,
AMBERNATH

Design Office