

SECTION C-C  
SCALE 2:1

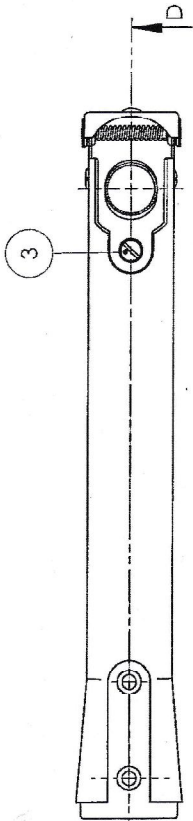

SECTION D-D

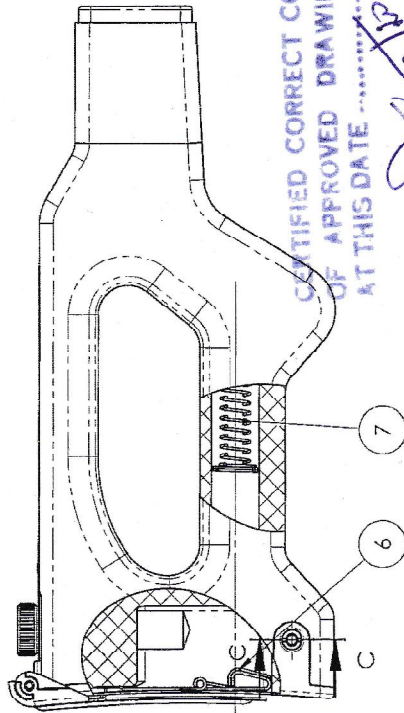
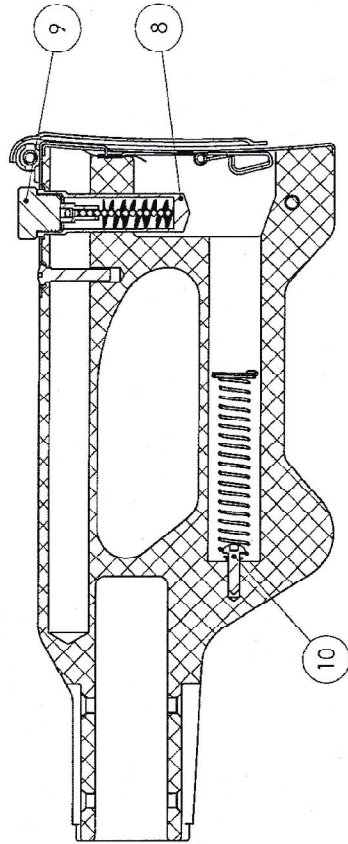
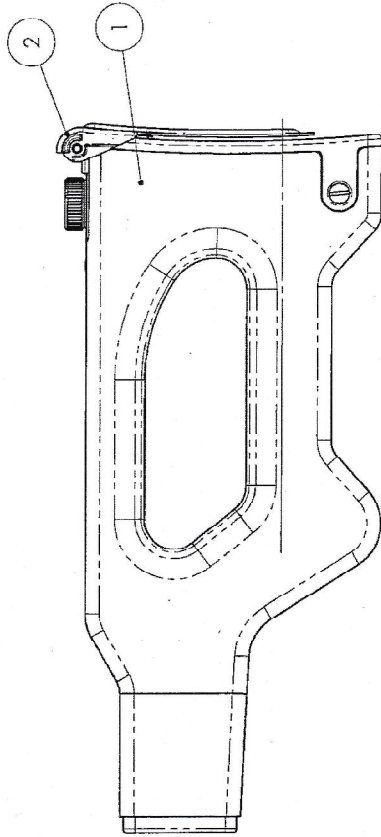

CERTIFIED CORRECT COPY  
OF APPROVED DRAWINGS  
AT THIS DATE .....

*[Signature]*  
Design & Drawing Office  
Ordnance Factory,  
Tiruchirappalli-620016

UN CONTROLLED COPY

ITEM NO.	PART NUMBER	QTY.
1	PKM-7201 BUTT	1
2	PKM-7210 BUTT PLATE ASSY	1
3	PKM-7202 SCREW TOP BUTT PLATE	1
4	PKM-7203 SCREW BOTTOM BUTT PLATE	1
5	PKM-7204 NUT PLAIN ROUND	1
6	PKM-7230 BUTT COVER ASSY	1
7	PKM-7205 SPRING	1
8	PKM-7207 OIL BOTTLE	1
9	PKM-7206 BRUSH OILING	1
10	GB_WOOD_SCREWS_TYPE131 5X18-S	1

SIGNATURE & DATE		SUB: BUTT ASSY		SCALE	
TRACED		FOR: GENERAL ASSY		NTS	
DRAWN <i>[Signature]</i> 8/8/20		OF: KALASHNIKOV MACHINE GUN(PKM)		STORE DRG.NO.	
CHECKED		DES. REF. NO.		OPERATION NO.	
HOS/D&DO		DRG. No.:		PKM - 7200	
OFFICER/PROJECT		ORDNANCE FACTORY		SHEETS: 1	
OFFICER/D&DO		TIRUCHIRAPPALLI-16.		SHEET No.: 1	
AMENDMENTS & DATE		APPROVED ON: 07.08.2020			

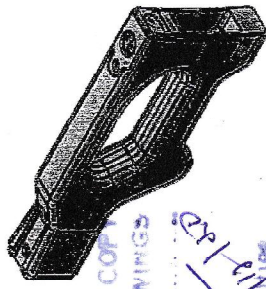

CERTIFIED CORRECT COPY  
OF APPROVED DRAWINGS  
AT THIS DATE

*exp 1-11-2015*

Design & Drawing Office  
Ordnance Factory,  
Vijayapuram-620016

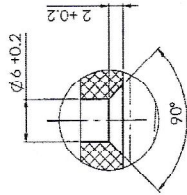

DETAIL A  
SCALE: 1:1

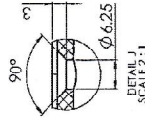
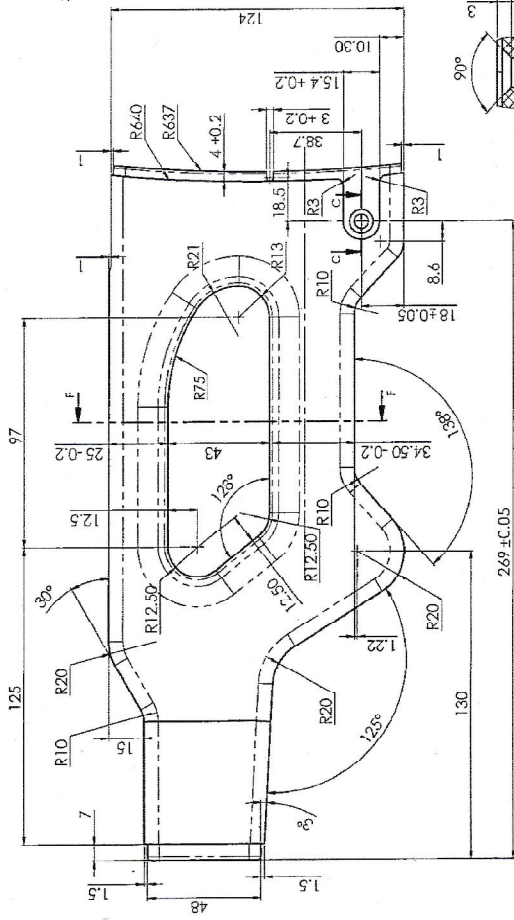
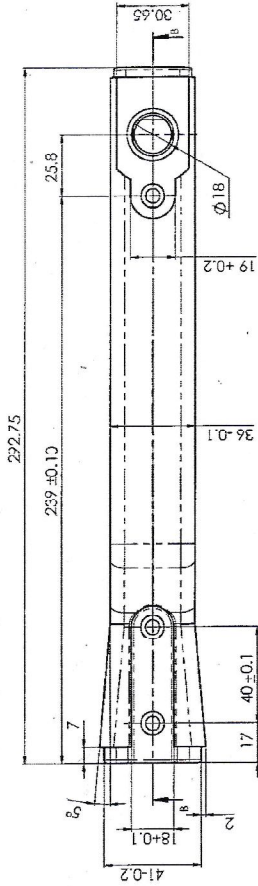

DETAIL B  
SCALE: 1:1

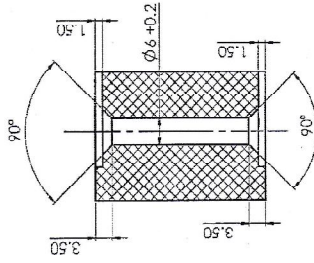

SECTION C-C  
SCALE: 1:1

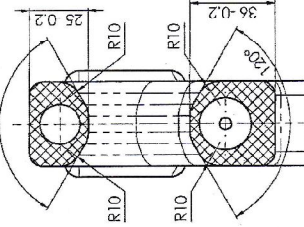

SECTION F-F

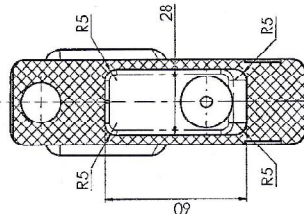

SECTION H-H

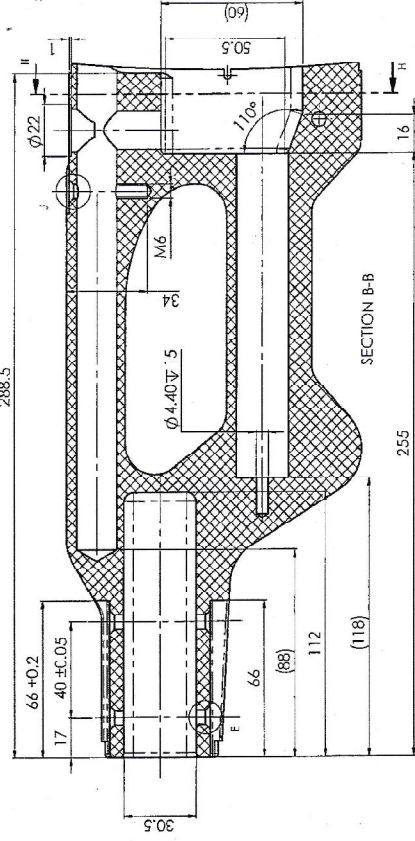

SECTION B-B

MATERIAL :- GLASS FIBRE REINFORCED  
POLYAMIDE (OR)  
NYLON 6 (OR) 66 .

MELTING POINT :- NOT LESS THAN 200 °C  
COLOUR :- MATT FINIS-1 BLACK

UN CONTROLLED COPY

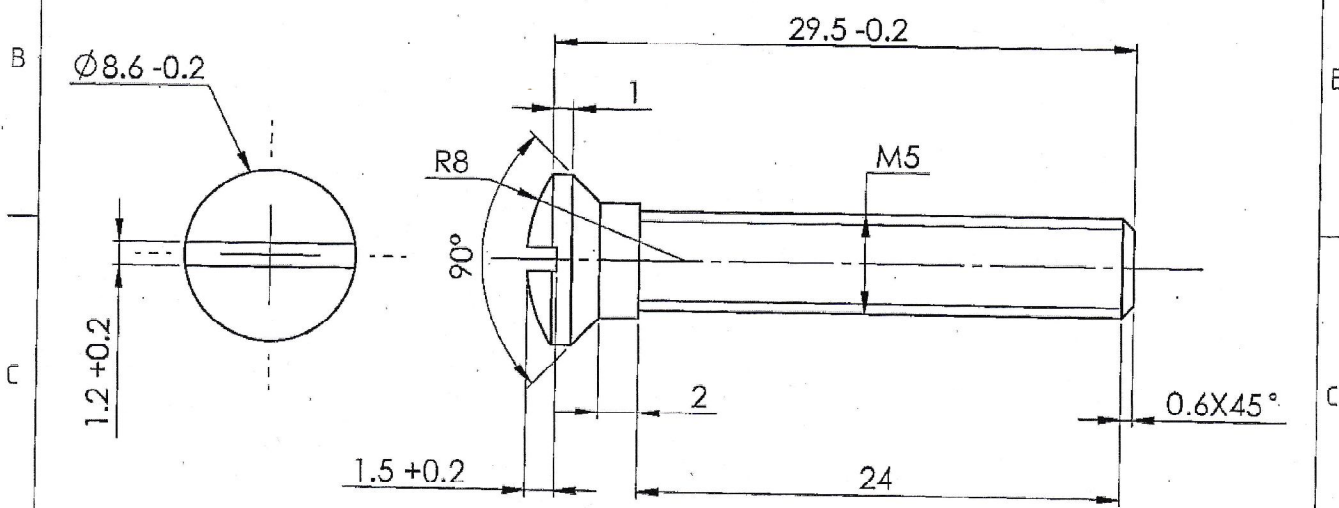

DWG Details Checked By 11/11/15 Design Office Ordnance Factory Vijayapuram-620016	Sub. BUIT BUIT ASSY (PCA-7200)	Do not start Drawing QFG
In accordance with IS: 10485 1st Edition 2001	P.M. - 7/21 (F)	Ordnance Factory Tiruchirappalli-16
DSK CONTROL		



MATERIAL :- STEEL BS:970 PT.3:1991 Gr.070 M20 (OR)  
 STANDARD WOODEN SCREW AS PER IS:280 STD,BRIGHT (OR)  
 STANDARD HARDWARE SCREWS (COLD DRAWN,THREAD ROLLING ) CAN BE USED.

VERIFIED CORRECT COPY  
 ORIGINAL DRAWINGS  
  
 8/12/20  
 Design & Drawing Office  
 Ordnance Factory,  
 Tiruchirappalli-620016

UN CONTROLLED COPY

AMENDMENTS	SIG. & DATE		SIGNATURE & DATE.	SUB: SCREW TOP BUTT PLATE	SCALE
		TRACED		FOR: BUTT ASSY (PKM-7200)	NTS
		DRAWN	<i>U</i> 7/8/20	OF: KALASHNIKOV MACHINE GUN(PKM)	Weight (g)
		CHECKED	<i>Jan</i>	DES.REF.NO.	REVISION
		OIC/D&DO	<i>P. Singh</i>	DRG. No.: PKM - 7202	SHEETS: 1
		DIV.OFFICER/ D&DO	<i>S. Kumar</i>	 ORDNANCE FACTORY TIRUCHIRAPPALLI-16.	SHEET No.: Sheet1
		APPROVED ON: 06.08.2020			

DRG. NO. PKM - 7203

DIMENSIONS ARE IN mm.  
 UNTOLERATED DIMNS. AS PER IS : 2102 (MED)

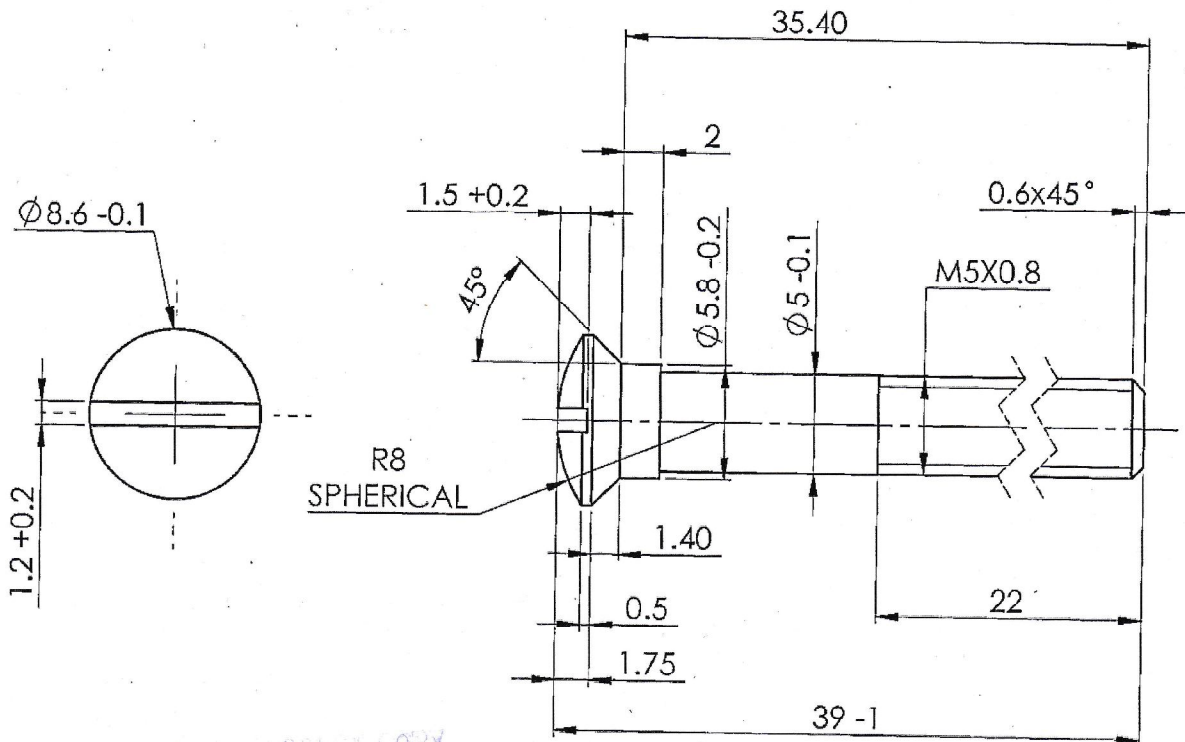

UNCONTROLLED COPY  
 DESIGN OFFICE  
 8/12/20  
 Tiruchirappalli-620016

MATERIAL :- STEEL BS.970 PT.3:1991 Gr.070 M20 (OR)  
 STANDARD WOODEN SCREW AS PER IS:280 STD,BRIGHT (OR)  
 STANDARD HARDWARE SCREWS (COLD DRAWN,THREAD ROLLING ) CAN BE USED.

UNCONTROLLED COPY

AMENDMENTS	SIG. & DATE		SIGNATURE & DATE.	SUB: SCREW BOTTOM BUTT PLATE	SCALE
		TRACED		FOR: BUTT ASSY (PKM -7200)	NTS
		DRAWN	<i>U</i> 7/8/20	OF: KALASHNIKOV MACHINE GUN(PKM)	Weight (g)
		CHECKED	<i>Ma</i>	DES. REF. NO. K-3005	REVISION
		O/C/D&DO	<i>P. Thy</i>	DRG. No.: PKM - 7203	SHEETS: 1
		DIV. OFFICER/D&DO	<i>Ge-K</i>	ORDNANCE FACTORY TIRUCHIRAPPALLI-16.	SHEET No.: Sheet1
APPROVED ON: 10.07.2020					

DRG. NO. PKM - 7204

DIMENSIONS ARE IN mm.

UNTOLERATED DIMNS. AS PER IS : 2102 (MED)

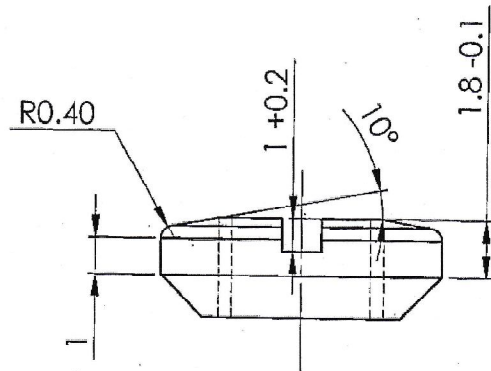
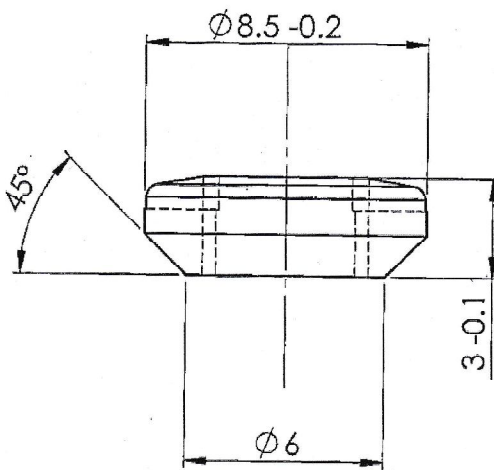
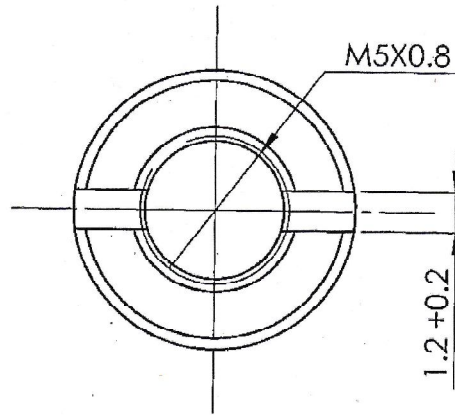

UN CONTROLLED COPY

*Handwritten signature and date: 8/18/20*  
 Ordnance Factory,  
 Tiruchirappalli

MATERIAL:-

IS:280-2006,SOFT OR 1/4 HARD, BRIGHT.

PROTECTIVE FINISH :- PHOSPHATED TO SPEC:

JSS:0465-01-1994 CLASS-II OIL FINISH.

AMENDMENTS	SIG. & DATE		SIGNATURE & DATE.	SUB: <b>NUT PLAIN ROUND</b>	SCALE NTS
		TRACED		FOR: <b>BUTT ASSY (PKM-7200)</b>	Weight (g)
		DRAWN	<i>U</i> 7/8/20	OF: KALASHNIKOV MACHINE GUN(PKM)	
		CHECKED	<i>PK</i>	DES. REF. NO. 65P 4016	REVISION
		OIC/D&DO	<i>P. J. K</i>	DRG. No.: PKM - 7204	SHEETS: 1
		DIV. OFFICER/D&DO	<i>S. K</i>	<b>ORDNANCE FACTORY TIRUCHIRAPPALLI - 16.</b>	SHEET No.: sheet1
APPROVED ON. 07.08.2020					

DRG NO. PKM - 7205

DIMENSIONS ARE IN mm.

UNTOLERATED DIMNS. AS PER IS : 2102 (MED)

WIRE DIA : 1mm

INNER DIA :

WOUND : R.H.(OR)L.H.

No. OF EFFECTIVE COILS:

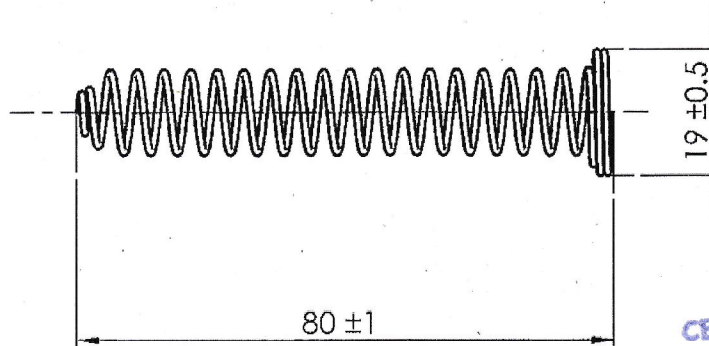

UN CONTROLLED COPY

CERTIFIED CORRECT COPY  
OF APPROVED DRAWINGS  
AT THIS DATE

*[Signature]*  
05/12/20  
Design & Drawing Office  
Ordnance Factory,  
Tiruchirappalli-620014

MATERIAL :- BS:5216:1975 Gr.5 Code 'M'

OR

IS:4454,Pt.1-2001 Gr.DH

PROTECTIVE FINISH :- PHOSPATED TO SPEC:

JSS:0465-01-1994 CLASS-II , OIL FINISH.

CRAMP TEST :- The spring to be compressed for a period of  
12 Hours before gauging .

Stress Relieve: 200 °C to 240 °C , 1Hr.

AMENDMENTS	SIG. & DATE		SIGNATURE & DATE.	SUB: SPRING	SCALE
		TRACED		FOR: BUTT ASSY	NTS
		DRAWN	<i>[Signature]</i>	OF: KALASHNIKOV MACHINE GUN(PKM)	Weight (g)
		CHECKED		DES.REF.NO.	REVISION
		OIC/D&DO	<i>[Signature]</i>	DRG. No.: PKM - 7205	SHEETS: 1
		OFFICER/PRODN.		ORDNANCE FACTORY TIRUCHIRAPPALLI-16.	SHEET No.: Sheet11
DIV.OFFICER/D&DO	<i>[Signature]</i>				
APPROVED ON. 24.09.20					

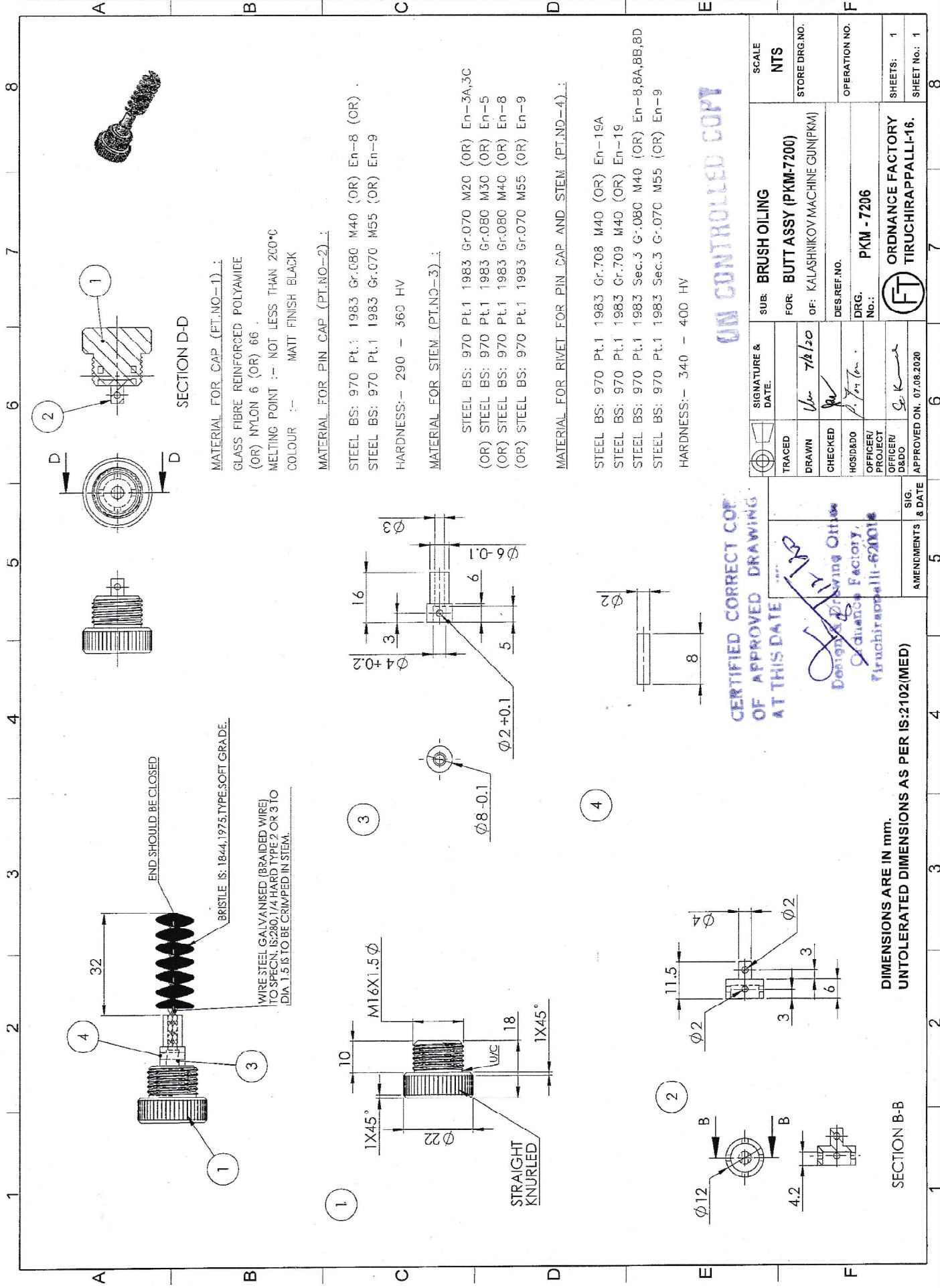

SECTION D-D

MATERIAL FOR CAP (PT.NO-1):  
 GLASS FIBRE REINFORCED POLYAMIDE  
 (OR) NYLON 6 (OR) 66  
 MELTING POINT :- NOT LESS THAN 200°C  
 COLOUR :- MATT FINISH BLACK

MATERIAL FOR PIN CAP (PT.NO-2):

STEEL BS: 970 Pt.1 1983 Gr.080 M40 (OR) En-8 (OR)  
 STEEL BS: 970 Pt.1 1983 Gr.070 M55 (OR) En-9  
 HARDNESS:- 290 - 360 HV

MATERIAL FOR STEM (PT.NO-3):

STEEL BS: 970 Pt.1 1983 Gr.070 M20 (OR) En-3A,3C  
 (OR) STEEL BS: 970 Pt.1 1983 Gr.080 M30 (OR) En-5  
 (OR) STEEL BS: 970 Pt.1 1983 Gr.080 M40 (OR) En-8  
 (OR) STEEL BS: 970 Pt.1 1983 Gr.070 M55 (OR) En-9

MATERIAL FOR RIVET FOR PIN CAP AND STEM (PT.NO-4):

STEEL BS: 970 Pt.1 1983 Gr.708 M40 (OR) En-19A  
 STEEL BS: 970 Pt.1 1983 Gr.709 M40 (OR) En-19  
 STEEL BS: 970 Pt.1 1983 Sec.3 G-080 M40 (OR) En-8,8A,8B,8D  
 STEEL BS: 970 Pt.1 1983 Sec.3 G-070 M55 (OR) En-9  
 HARDNESS:- 340 - 400 HV

UN CONTROLLED COPY

CERTIFIED CORRECT COPY OF APPROVED DRAWING AT THIS DATE

SIGNATURE & DATE:	SUB: BRUSH OILING	SCALE: NTS
	FOR: BUTT ASSY (PKM-7200)	STORE DRG.NO.
TRACED	DESIGNER: 7h/20	OPERATION NO.
DRAWN	OF: KALASHNIKOV MACHINE GUN (PKM)	
CHECKED	DESIGNER: [Signature]	
HOSIDARO	DRG. No.: PKM - 7206	
OFFICER/PROJECT		
OFFICER/D&O		
 <b>ORDNANCE FACTORY TIRUCHIRAPPALLI-16.</b>		SHEETS: 1
APPROVED ON: 07.08.2020		SHEET No.: 1

DIMENSIONS ARE IN mm. UNTOLERATED DIMENSIONS AS PER IS:2102(MED)

SECTION B-B

Design Drawing Office  
 Ordnance Factory,  
 Tiruchirappalli-620016

AMENDMENTS & DATE	SIG. & DATE

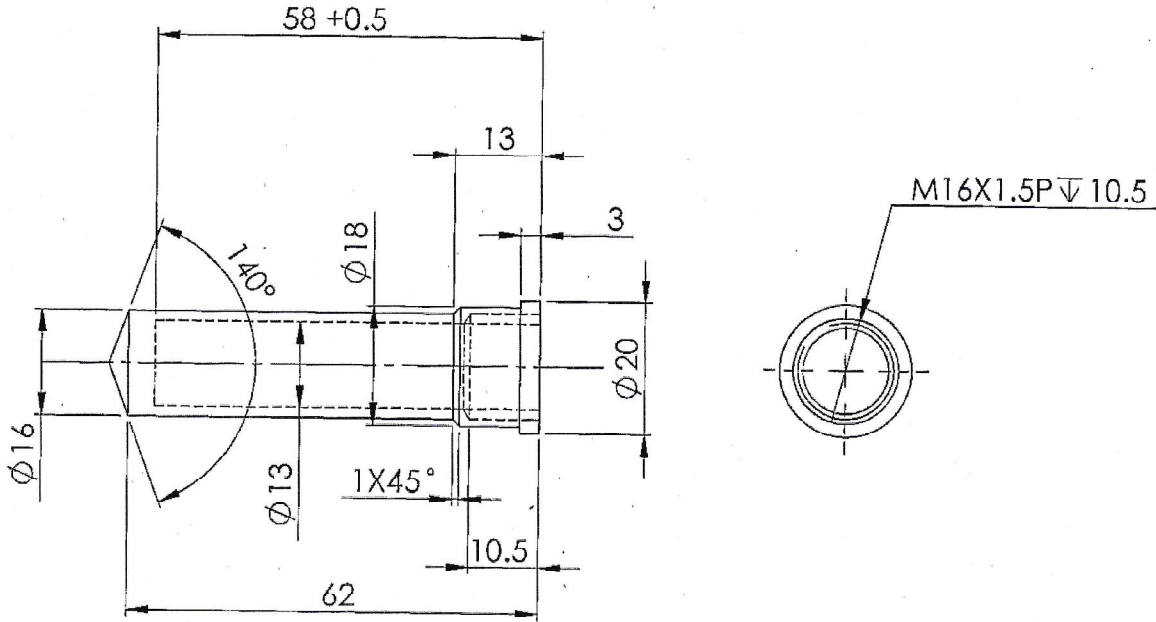

GLASS FIBRE REINFORCED POLYAMIDE  
(OR) NYLON 6 (OR) 66  
MELTING POINT :- NOT LESS THAN 200°C  
COLOUR :- MATT FINISH BLACK

UN CONTROLLED COPY

NOTE: DIA 18 SHOULD BE TIGHTLY FITTED WITH PART( PKM-7201) IN ASSY.

CERTIFIED CORRECT COPY  
 OF APPROVED DRAWING  
 AT THIS DATE  
 Design & Drawing Office  
 Ordnance Factory,  
 Tiruchirappalli-620016

	SIGNATURE & DATE.		SUB: OIL BOTTLE	SCALE
	TRACED		FOR: BUTT ASSY (PKM-7200)	NTS
	DRAWN	<i>U</i> 7/8/20	OF: KALASHNIKOV MACHINE GUN(PKM)	Weight (g)
	CHECKED	<i>P</i>	DES. REF. NO. R-6421	REVISION
	OIC/D&DO	<i>P. Jayar</i>	DRG. No.: PKM - 7207	
	OFFICER/ PRODN.		ORDNANCE FACTORY TIRUCHIRAPPALLI-16.	SHEETS: 1
DIV. OFFICER/ D&DO	<i>S. Kumar</i>	SHEET No.: Sheet1		
AMENDMENTS	SIG. & DATE	APPROVED ON. 07.08.2020		



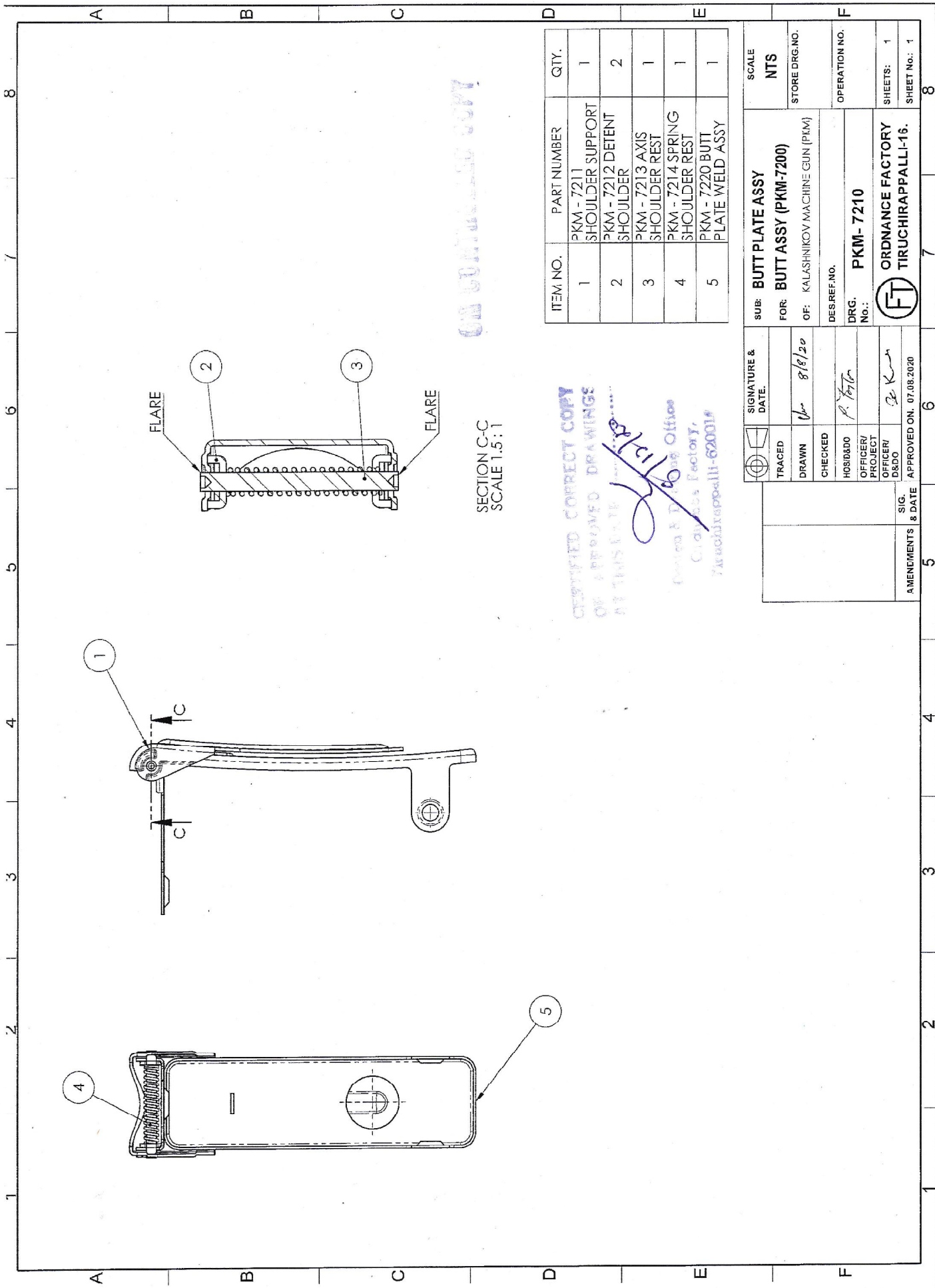

SECTION C-C  
SCALE 1.5:1

ORIGINAL COPY

CERTIFIED CORRECT COPY  
 OF APPROVED DRAWINGS  
 AT THIS DATE 12/18/20  
 Ordnance & Training Office  
 Ordnance Factory,  
 Tiruchirappalli-620015

ITEM NO.	PART NUMBER	QTY.
1	PKM - 7211 SHOULDER SUPPORT	1
2	PKM - 7212 DETENT SHOULDER	2
3	PKM - 7213 AXIS SHOULDER REST	1
4	PKM - 7214 SPRING SHOULDER REST	1
5	PKM - 7220 BUTT PLATE WELD ASSY	1

SIGNATURE & DATE		SCALE	
TRACED		NTS	
DRAWN	W 8/8/20	STORE DRG. NO.	
CHECKED		OPERATION NO.	
HOS/BSDO		DRG. No.: PKM-7210	
OFFICER/PROJECT		DES. REF. NO.	
OFFICER/D&DO		SUB: BUTT PLATE ASSY	
AMENDMENTS & DATE		FOR: BUTT ASSY (PKM-7200)	
SIGNED & DATE		OF: KALASHNIKOV MACHINE GUN (PKM)	
APPROVED ON. 07.08.2020		DRG. No.: PKM-7210	
		DES. REF. NO.	
		ORDNANCE FACTORY TIRUCHIRAPPALLI-16.	
		SHEETS: 1	
		SHEET No.: 1	



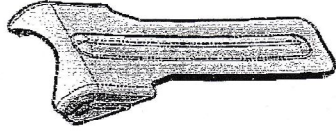
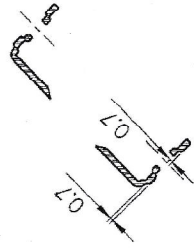
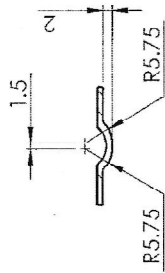
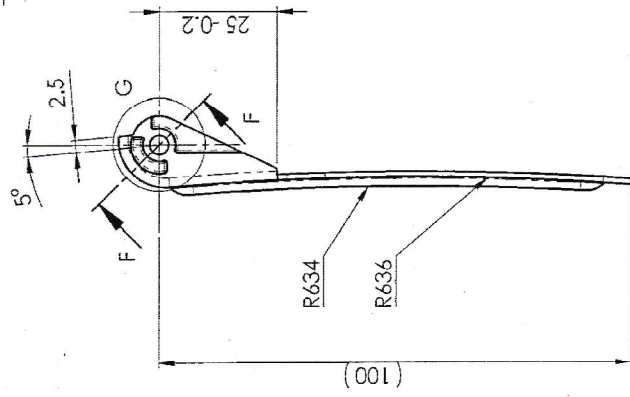
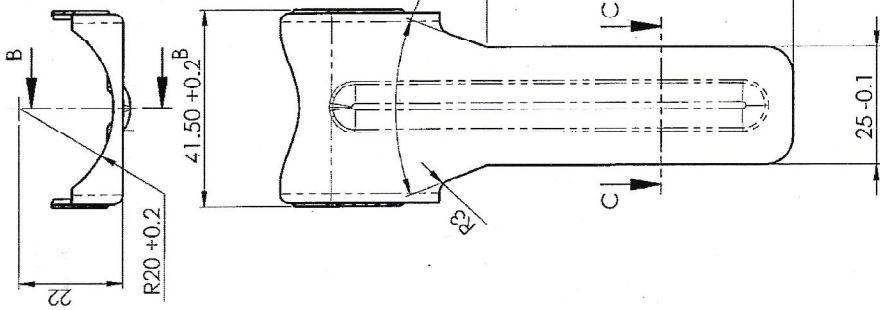

MATERIAL:- Steel Sheet 1mm

BS:1449 Pt-1 1983 Gr CS50

IS:2507-1975 Gr-2 55 C6

HARDNESS:- 320 - 380 HV

PROTECTIVE FINISH :- PHOSPHATED TO SPEC:

JSS:0465-01-1994 CLASS-II OIL FINISH.

DIMENSIONS ARE IN mm.

UNTOLERATED DIMENSIONS AS PER IS:2102(MED)

SECTION B-B

ORIGINAL COPY ONLY  
OF APPROVED DRAWINGS  
ISSUED BY THE  
DESIGN OFFICE

Handwritten signature and date: 7/8/20

TRACED	SIGNATURE & DATE	SUB: SHOULDER SUPPORT	SCALE
DRAWN	7/8/20	FOF: BUTT PLATE ASSY	NTS
CHECKED		OF: KALASHNIKOV MACHINE GUN(PKM)	STORE DRG.NO.
HOSBDDO		DES REF.NO.	OPERATION NO.
OFFICER/PROJECT		DRG. No.: PKM - 7211	SHEETS: 1
OFFICER/D&DO			SHEET No.: 1
APPROVED ON: 25.06.2020			

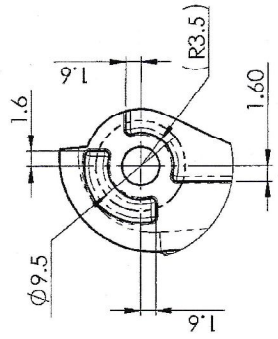

DETAIL G  
SCALE 2:1

