











1	2		3		4		5		6		7		8	
A	SHEET: 1 OF 1 gm	ORDNANCE FACTORY TIRUCHIRAPPALLI-16.						AMENDMENT DATE	22-4-22	002/2022				
A	WT. (Approx)	A3	DWC. 27P 6100 *	No.:		DDO Div. Officer	Finish	22-4-22	22-4-22	002/2022				
B	All Dimensions are in mm	A3	Design Ref DS.CAT No.1005-007723	No.:		DDO Div. Officer	Hardness	22-4-22	22-4-22	002/2022				
C	Drawing	A3	Proj: 7.62 mm 1A1	No.:		DDO Div. Officer	HOS/D&DO	22-4-22	22-4-22	002/2022				
D	Do not scale	A3	FOR: 17-4-22	No.:		DDO Div. Officer	CHECKED	17-4-22	17-4-22	002/2022				
E	SUB: GUARD HAND LEFT & RIGHT ASSY.(POLYMER)	A3	DATE: 17-4-22	No.:		DDO Div. Officer	DRAWN	17-4-22	17-4-22	002/2022				
F	Material:	A3	SIGN	No.:		DDO Div. Officer	3rd Angle	17-4-22	17-4-22	002/2022				
	DWG Details	A3	DATE: 17-4-22	No.:		DDO Div. Officer	DRAWN	17-4-22	17-4-22	002/2022				
	Material:	A3	SIGN	No.:		DDO Div. Officer	3rd Angle	17-4-22	17-4-22	002/2022				
	DWG Details	A3	DATE: 17-4-22	No.:		DDO Div. Officer	DRAWN	17-4-22	17-4-22	002/2022				
	Material:	A3	SIGN	No.:		DDO Div. Officer	3rd Angle	17-4-22	17-4-22	002/2022				

SECTION A-A



UN CONTROLLED COPY
CERTIFIED CORRECT COPY OF APPROVED
DRAWINGS AT THIS DATE. 30/4/22
DESIGN & DRAWING OFFICE
ORDNANCE FACTORY, TIRUCHIRAPPALLI-620 016.

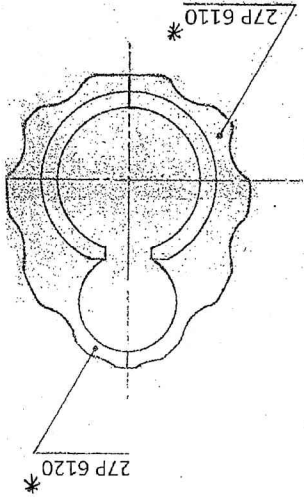
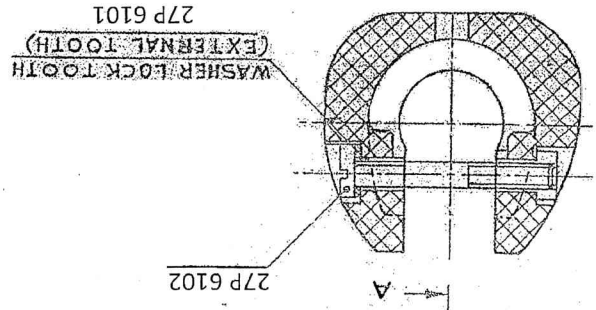
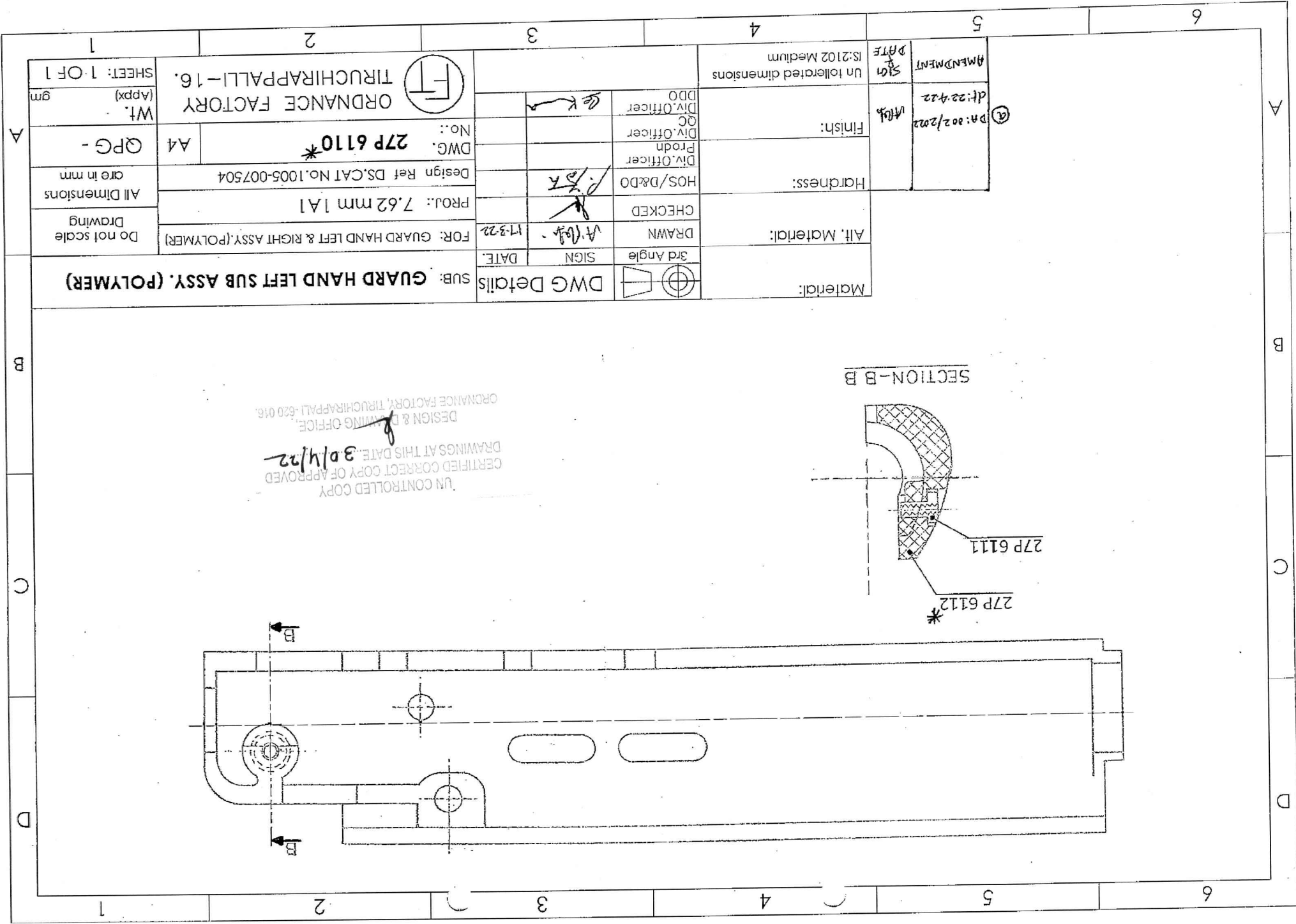

1	2	3	4	5	6
A	DWG. 27P 6120* No.: Design Ref DS.CAT No.1005-007507 All Dimensions are in mm Do not scale Drawing		TIRUCHIRAPPALLI-16. ORDINANCE FACTORY WT. (approx) gm SHEET: 1 OF 1	AMENDMENT DA: 002/2022 DT: 22-4-22 AMV.	(A)
	SUB: GUARD HAND RIGHT SUB ASSY.(POLYMER) FOR: (POLYMER) DATE: 17-3-22	DWG Details 3rd angle SIGN DATE:	Material: Alt. Material: DRAWN CHECKED HOS/D&DO Div. Officer Prodn Div. Officer Div. Officer Div. Officer DDO	Hardness: Finish:	

SECTION A-A

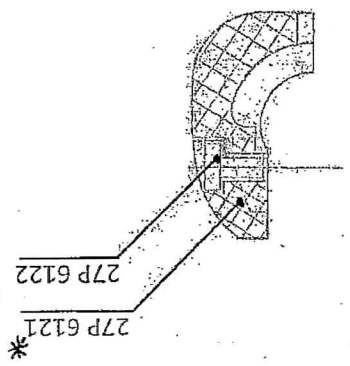

UN CONTROLLED COPY
 CERTIFIED CORRECT COPY OF APPROVED
 DRAWINGS AT THIS DATE: 30/4/22
 DESIGN & DRAWING OFFICE,
 ORDINANCE FACTORY, TIRUCHIRAPPALLI-620 016.

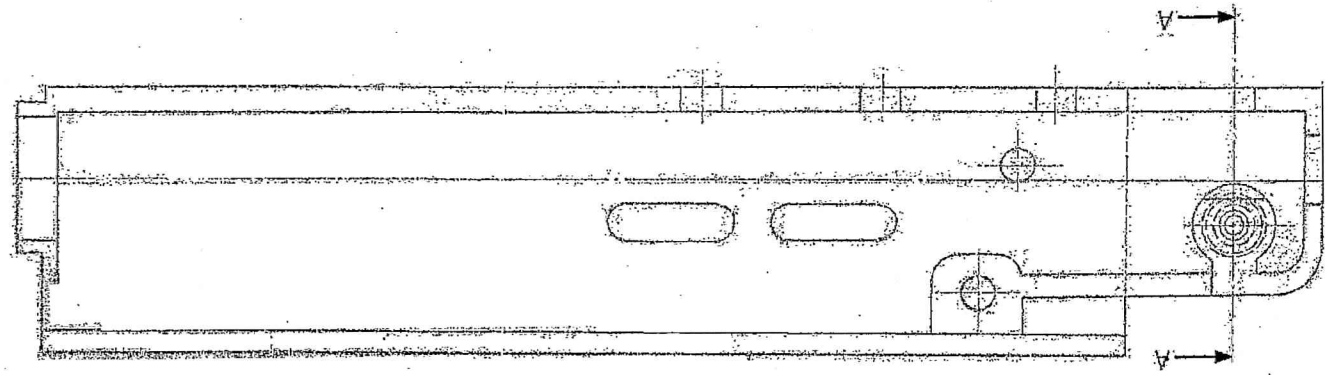

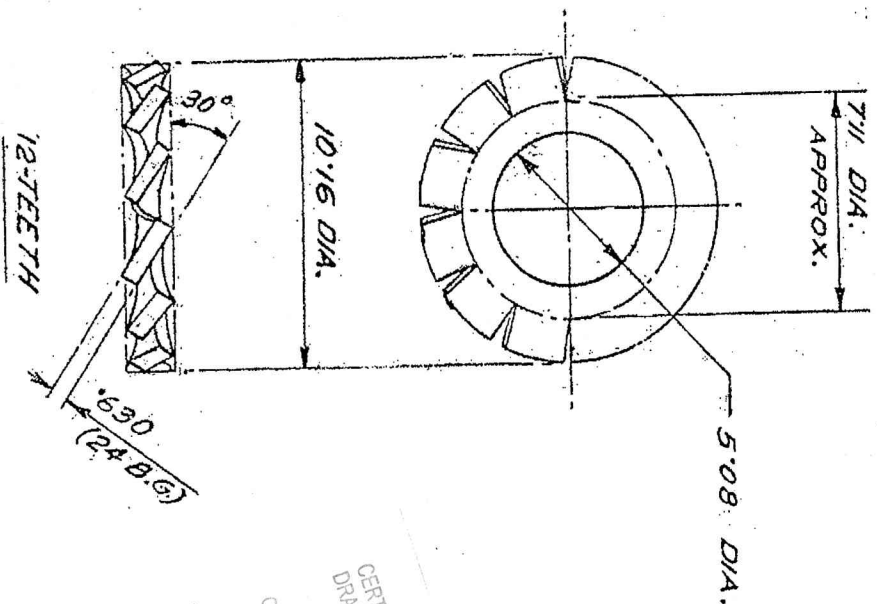

UN CONTROLLED COPY
 CERTIFIED CORRECT COPY OF APPROVED
 DRAWINGS AT THIS DATE: 21/11/2019
 DESIGN & DRAWING OFFICE:
 ORDNANCE FACTORY, TIRUCHIRAPPALLI-620 016.

NOTE:
 WHERE TOLERANCES ARE NOT SHOWN,
 DIMENSIONS IN WHOLE NUMBER +1.27 mm
 DIMENSIONS IN ONE DECIMAL PLACES +0.4 mm
 DIMENSIONS IN TWO DECIMAL PLACES +0.13 mm

TREAT:HARDENED & TEMPERED TO HV 450 TO 550 (59-65 HRD)

Material: STEEL BS:1 449 PT.1:1983 CS 70 TO CS 80			DWG Details		SUB: WASHER LOCK (TOOTH TYPE) (EXTERNAL TOOTH)		FOR: GUARD HAND LEFT & RIGHT ASSY. (POLYMER)		Do not scale Drawing	
Alt. Material:		DRAWN	SIGN	DATE	PROJ.: 7.62 mm 1A1		Design Ref DS,CAT No.1005-001718 (ICR 1517)		All Dimensions are in mm	
Hardness:		CHECKED		11.3.22	DWG. No.:		27P 6101		A4	
Finish:		HOS/D&DO			ORDNANCE FACTORY		TIRUCHIRAPPALLI-16.		WT. (Appx) gm	
Phosphating to JSS3045-01-1988. Class-II Oil finish		Div. Officer QC			FT		SHEET: 1 OF 1			
		Div. Officer DDO								

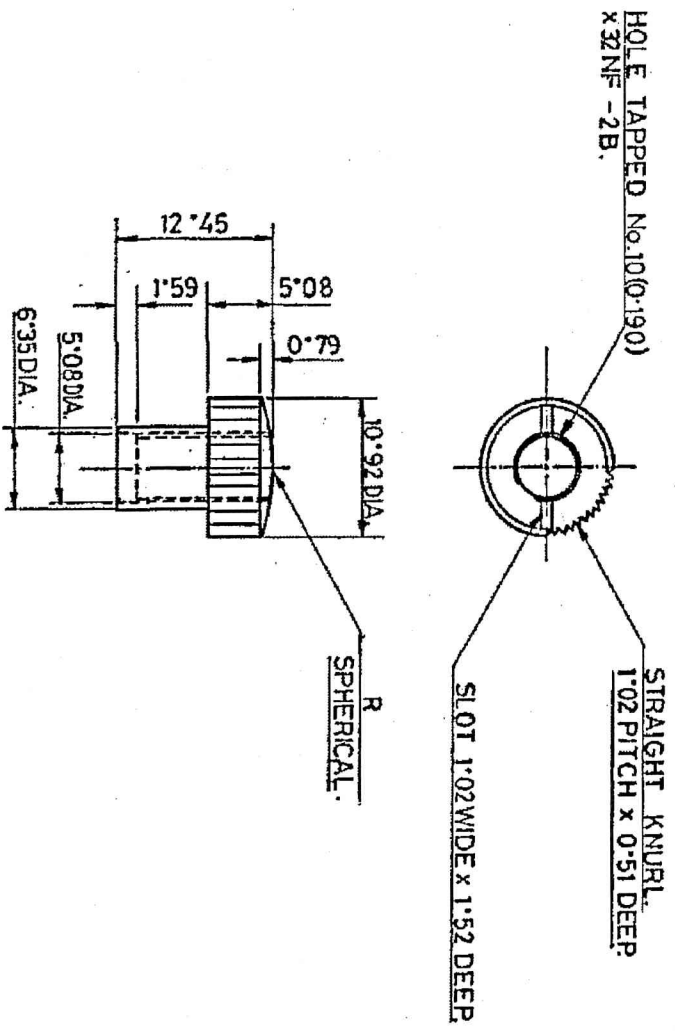

UN CONTROLLED COPY
 CERTIFIED CORRECT COPY OF APPROVED
 DRAWINGS AT THIS DATE 21/05/20
 DESIGN & DRAWING OFFICE,
 ORDNANCE FACTORY, TIRUCHIRAPPALLI-620 016.

NOTE:
 FOR SPECIFICATION LATEST ISSUE SHOULD BE FOLLOWED
 FOR EXPLANATION OF DETAILS WHEREVER NOT SPECIFIED,
 REFER D.D.NOTE SHEET No.3. (LATEST ISSUE)

Material: IS:517-1993 DESIGNATION 30C8		DWG Details	SIGN	DATE:	
Alt. Material:	DRAWN			17.3.22	
Hardness:	CHECKED				
Finish: Phosphating to JSS0465-01-1988, Class-I Oil finish	HOS./D&DO				
	Div. Officer Prodn				
	Div. Officer QC				
	Div. Officer DDO				

SUB: **NUT HAND GUARD SCREW**

FOR: GUARD HAND LEFT SUB ASSY (POLYMER)
 PROJ.: 7.62 mm 1A1

Design Ref DS.CAT No.5310-003171 (ICR 1276)
 DWG. No.: **27P 6111**

ORDNANCE FACTORY
 TIRUCHIRAPPALLI-16.

Do not scale
 Drawing
 All Dimensions
 are in mm

WT.
 (Appx) gm
 SHEET: 1 OF 1

4 3 2 1

A B C D E F

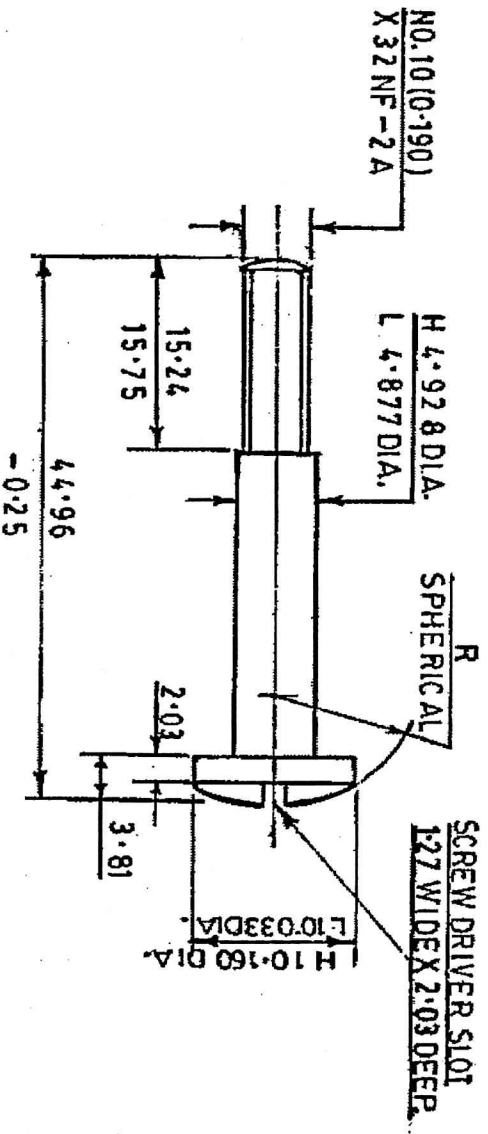

UN CONTROLLED COPY
 CERTIFIED CORRECT COPY OF APPROVED
 DRAWINGS AT THIS DATE... 31/05/22

DESIGN & DRAWING OFFICE,
 ORDNANCE FACTORY, TIRUCHIRAPPALLI-620 016.

NOTE:
 FOR SPECIFICATION LATEST ISSUE SHOULD BE FOLLOWED
 FOR EXPLANATION OF DETAILS WHEREVER NOT SPECIFIED,
 REFER D.D.NOTE SHEET No.3 (LATEST ISSUE)

Material: IS:5517-1993 DESIGNATION 42 Cr4Mo2		DWG Details	
	3rd Angle	SIGN	DATE.
Alt. Material:	DRAWN	<i>M. S. P.</i>	17-3-22
	CHECKED		
Hardness: 300-350 HV (47-52 HRD)	HOS / D&DO	<i>[Signature]</i>	
	Div. Officer Prodn		
	Div. Officer QC		
	Div. Officer DDO	<i>[Signature]</i>	
Finish: Phosphating to JSS04&5-01-1988, Class II Oil finish			
SUB: SCREW HAND GUARD		FOR: GUARD HAND LEFT AND RIGHT ASSY (POLYMER)	
PROJ.: 7.62 mm 1A1		Do not scale Drawing	
Design Ref DS,CAT No.5305-005008 (ICR 1196)		All Dimensions are in mm	
DWG. No.:	27P 6102	A4	QPG -
ORDNANCE FACTORY TIRUCHIRAPPALLI-16.		Wt. (Appx)	gm
		SHEET: 1 OF 1	

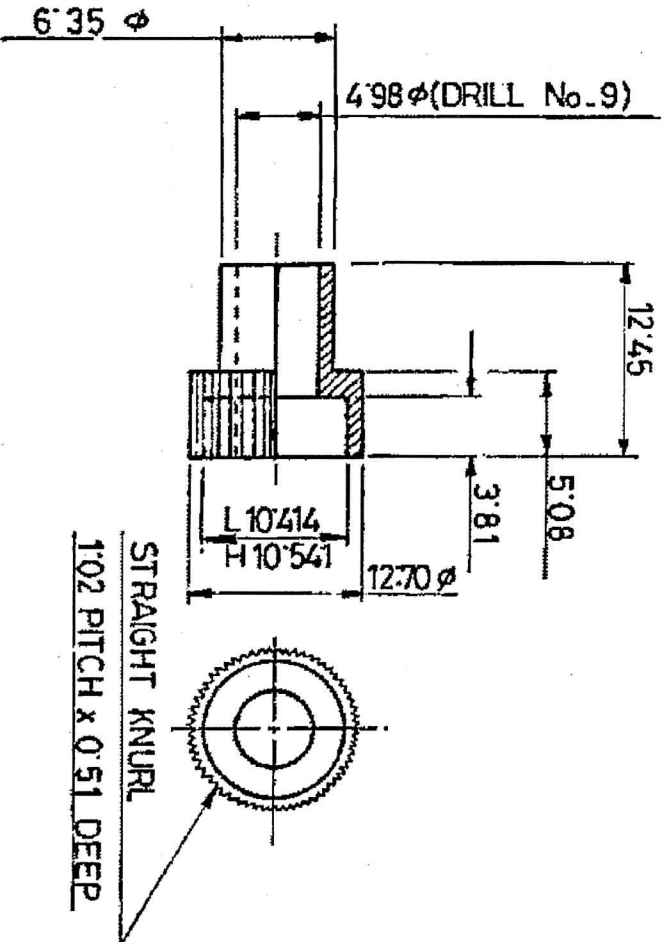

UN CONTROLLED COPY,
 CERTIFIED CORRECT COPY OF APPROVED
 DRAWINGS AT THIS DATE... 31/05/22
 DESIGN & DRAWING OFFICE,
 ORDNANCE FACTORY, THIRUCHIRAPPALLI - 620 016.

NOTE:
 WHERE TOLERANCES ARE NOT SHOWN,
 DIMENSIONS IN WHOLE NUMBER ± 1.27 mm
 DIMENSIONS IN ONE DECIMAL PLACES ± 0.4 mm
 DIMENSIONS IN TWO DECIMAL PLACES ± 0.13 mm

FOR EXPLANATION REFER D.D. NOTE SHEET No.3. (LATEST ISSUE).

Material: IS:5517-1993, DESIGNATION 30 C8		DWG Details	
	3rd Angle	SIGN	DATE:
Alt. Material:	DRAWN	<i>M.K.</i>	17-3-22
Hardness:	CHECKED	<i>[Signature]</i>	
	HOS/D&DO	<i>P. K.</i>	
Finish: Phosphating to JSS3045-01-1988, Class-I Oil finish	Div. Officer Prod'n		
	Div. Officer QC		
	Div. Officer DDO	<i>[Signature]</i>	
SUB: SLEEVE HANDGUARD		FOR: GUARD RIGHT SUB ASSY. (POLYMER)	
PROJ.: 7.62 mm 1A1		Design Ref DS. CAT No. 1005-001593 (ICR 1278)	
DWG. No.: 27P 6122		A4	QPG -
ORDNANCE FACTORY THIRUCHIRAPPALLI - 16.		Do not scale Drawing	
WT. (Appx) gm		All Dimensions are in mm	
SHEET: 1 OF 1			