

21-198



FIRST ANGLE PROJECTION

РАСЧЕТНО-ТЕХНИЧЕСКАЯ СЛУЖБА

С.И. КОЗЛОВ

ЛИСТ № 1 из 1

A-A

~ *осмотрное*  
~ Unless otherwise specified.

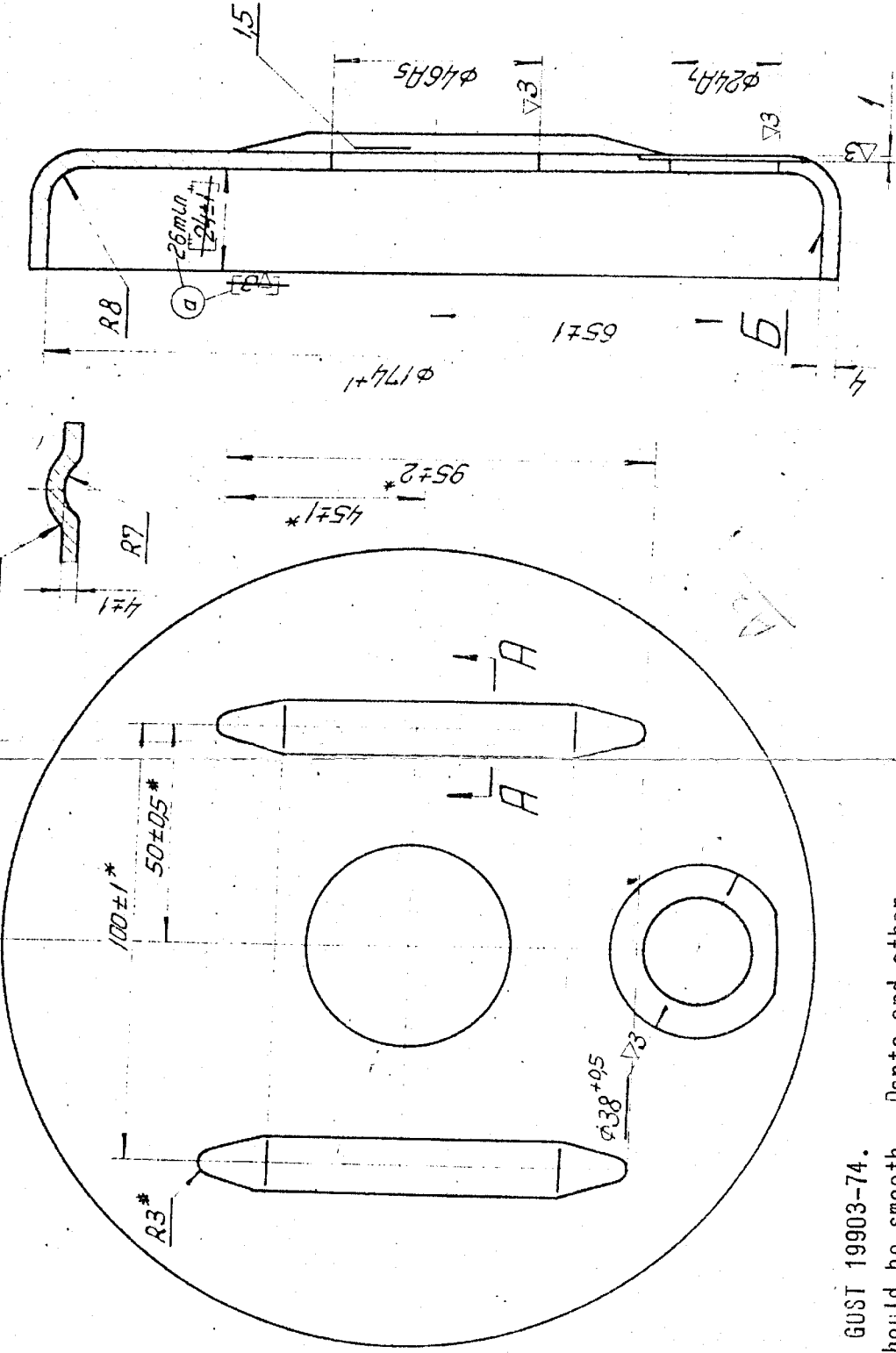

1. Sheet B -4 GUST 19903-74.
2. Surface B should be smooth. Dents and other unevenness are not allowed.
3. Out-of-roundness of surface B is not to be greater than 0.5mm.
4. Blunt sharp edges,  $R \approx 0.6\text{mm}$ .
6. \* Dimensions for tools.

ALT MATL: - STEEL, Fe 410, IS: 1079-88

1706-W	ALT MATL	1706-W	SCALE
14-9-93	ADDED	1706-W	SCALE
ISSUE	DATE	REFERENCE	SCALE
APPROVED	DATE	REFERENCE	SCALE
CHECKED	DATE	REFERENCE	SCALE
DRAWN	DATE	REFERENCE	SCALE
MATERIAL: STEEL 25 GOST 1577-70			
C.Q.A(AVA)AVADI			
HAND WHEEL RIM		2A20	
21-198		21-198	
SHEET	MASS	SCALE	SCALE
1 of 1	1.04	1:1	1:1

2A46.21-29

18-8908

Rz80

FIRST ANGLE PROJECTION

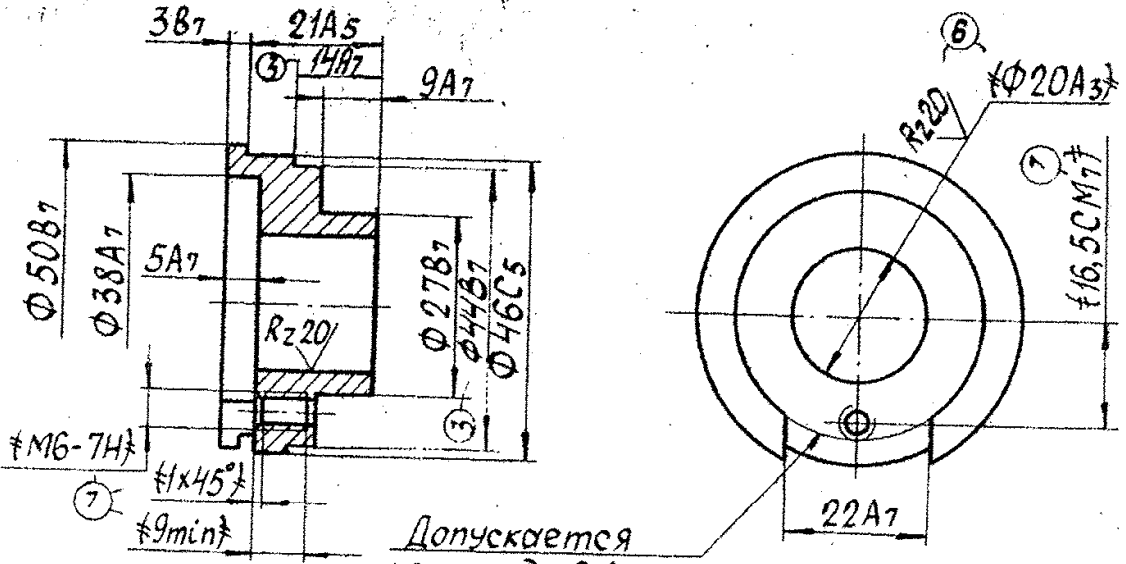

Допускается  
умень до 0,1 мм.  
Shoulder to 0.1mm is  
allowed.

ALT MATL :- STEEL 070 M 20, BS: 970 PE 1-83, (NORMALISED)

1. Mark the article index and the part number on the tag.
2. Alternate material - steel 25 GOST 1050-74.

22-4-85 DRG SEALED PKOV

330M.4H6N.4H6A.10246A.Подп. и дата

18914-W 22-10-03	HINDI NOMN. ADDED.	MMA
17679-W 27-7-93	ALT MATL ADDED.	KSVVLS C/D
17558-W 7-5-91	PROY. SEALING CANCELLED AND DRG SEALED	C/D

			2A46. 21-29		
			HUB	(27)	1 of 1
			SHEET	MASS	SCALE
			1 of 1	0.2	1:1
ISSUE	DATE	REFERENCE			
APPROVED	<i>[Signature]</i>	23/1/94	MATERIAL:		
CHECKED	<i>[Signature]</i>	26/6/94	STEEL 20-2 GOST 1050-74.		
DRAWN	C. Damsaran	26/6/94	CQA(AVA)AVADI		

T-72

AF-3

2446 21-38

FIRST ANGLE PROJECTION

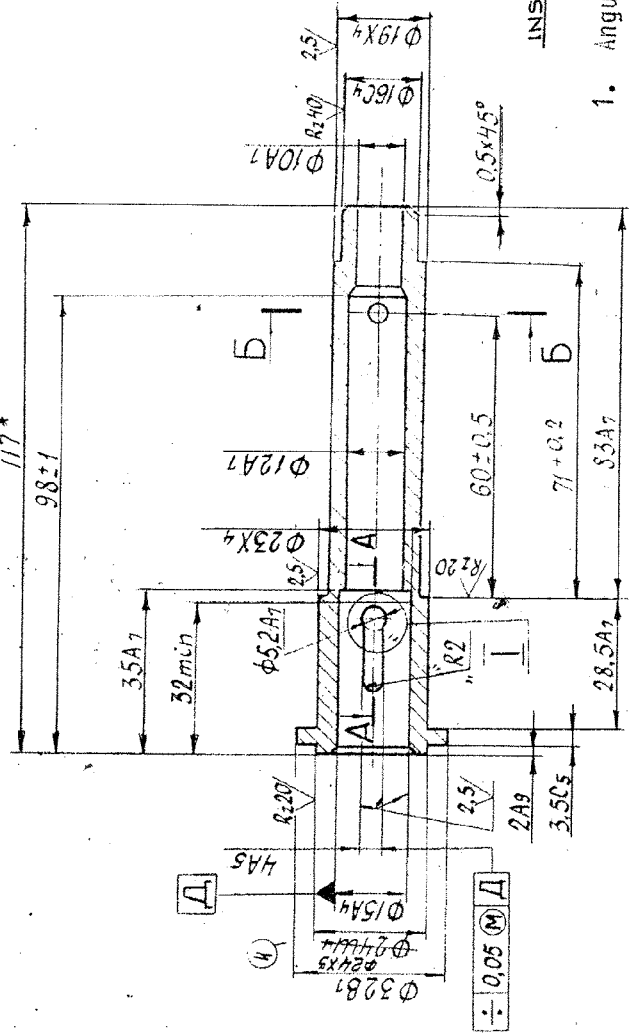

B-B

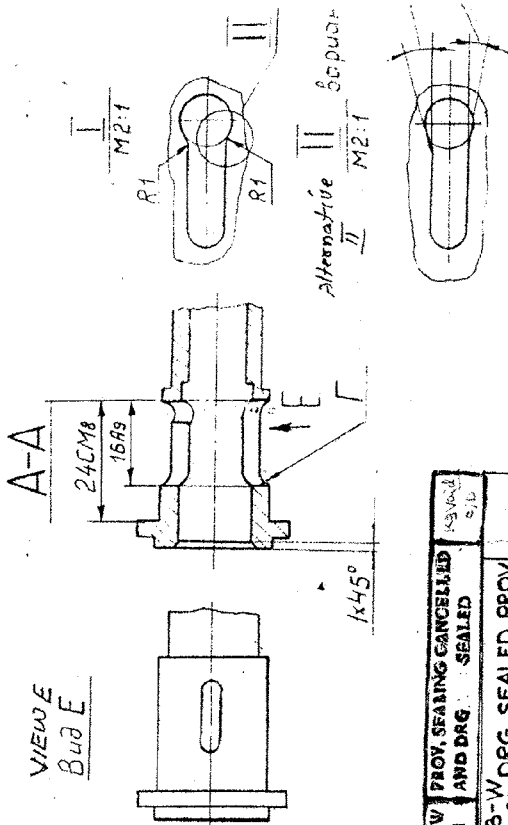
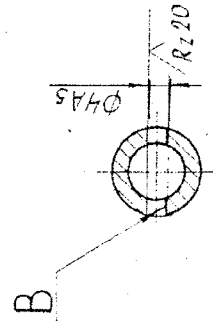

INSPECTION NOTE:- FOR LIST OF GAUGES AND FIXTURES  
 REFER GAUGE SHT.No.GS(W)-1004.B SHT.1 & SHT.2.

1. Angular shift of hole B with respect to slot F is allowed to be  $\pm 30$ .
- \* Dimension for reference.
3. Mark the index of the article and the part number on the tag.

ALT MATL:- STEEL, 655 M13.B5.970PT1:83

1884-W	HINDINOMEN-ADDED.	NEW	SHEET	MASS	SCALE
17717-W	ALT MATL	14/11/83	1 of 1	0.16	1:1
14.9.93	ADDED.	14/11/83			
APPROVED	DATE	REFERENCE			
CHECKED	DATE	REFERENCE			
DRAWN	DATE	REFERENCE			
2A46.21-38					
HANDLE BAR					
S.S. Q17					
MATERIAL: CQA(AVA) AVADI					
STEEL 12X.H3A GOST 4543-71					
K 760-II-0873-1586-73					

1068-W | PROJ. SEALING CANCELLED  
 7-5-91 | AND DRG. SEALED  
 16313-W | DRG SEALED PROV

AF-3

68-12 9HYZ 2A46-81

FIRST ANGLE PROJECTION

Восстановленный по чертежу №1

Rz160

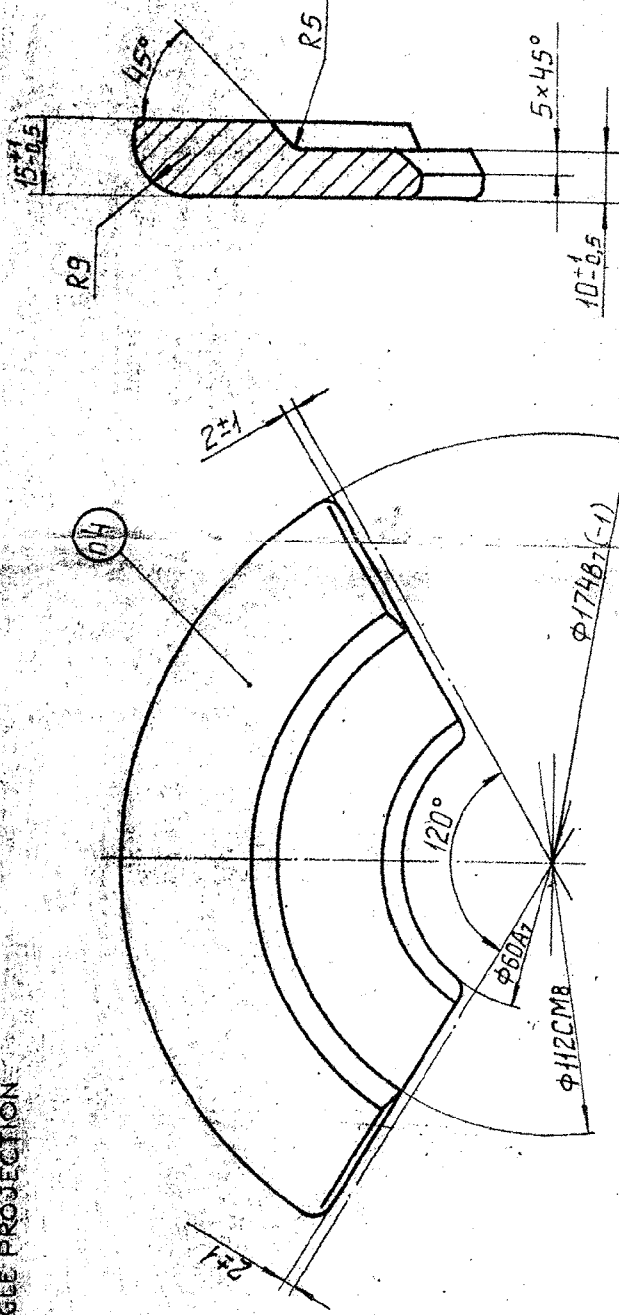

1. Forging group I GOST 8479-70.
2. Unspecified fillet radii, 3 mm.
3. Draft 7°.
4. Mark the index of the article and the part number. Типло-3 GOST 2930-62.
5. Alternate material is steel 25 GOST 1050-74.

ALT. MATL: - STEEL, GRADE 20, Mn 2, IS : 4368-67

16313-W	DRG SEALED/PROV	17708-W	ALT MATL ADDED.
17058-W	PROV, SEALING CANCELLED	17708-W	ALT MATL ADDED.
16313-W	DRG SEALED/PROV	17708-W	ALT MATL ADDED.

ISSUE	DATE	APPROVED	REFERENCE
22/10/83			
CHECKED			
DRAWN			
MATERIAL: STEEL 3 cm 3cm			
4 GOST 380-71			
COUNTER WEIGHT		2A46. 21-89	
SHEET	MASS	SCALE	
1 of 1	0.5	1:1	
CQA(AVA)AVADI			

AF-3

Восстановлен с подшипника №1 в з.з. Верно. Подпись: [Signature]

ТОПН Глазман Подпись  
ОГТ Безруков Подпись 1.05.76

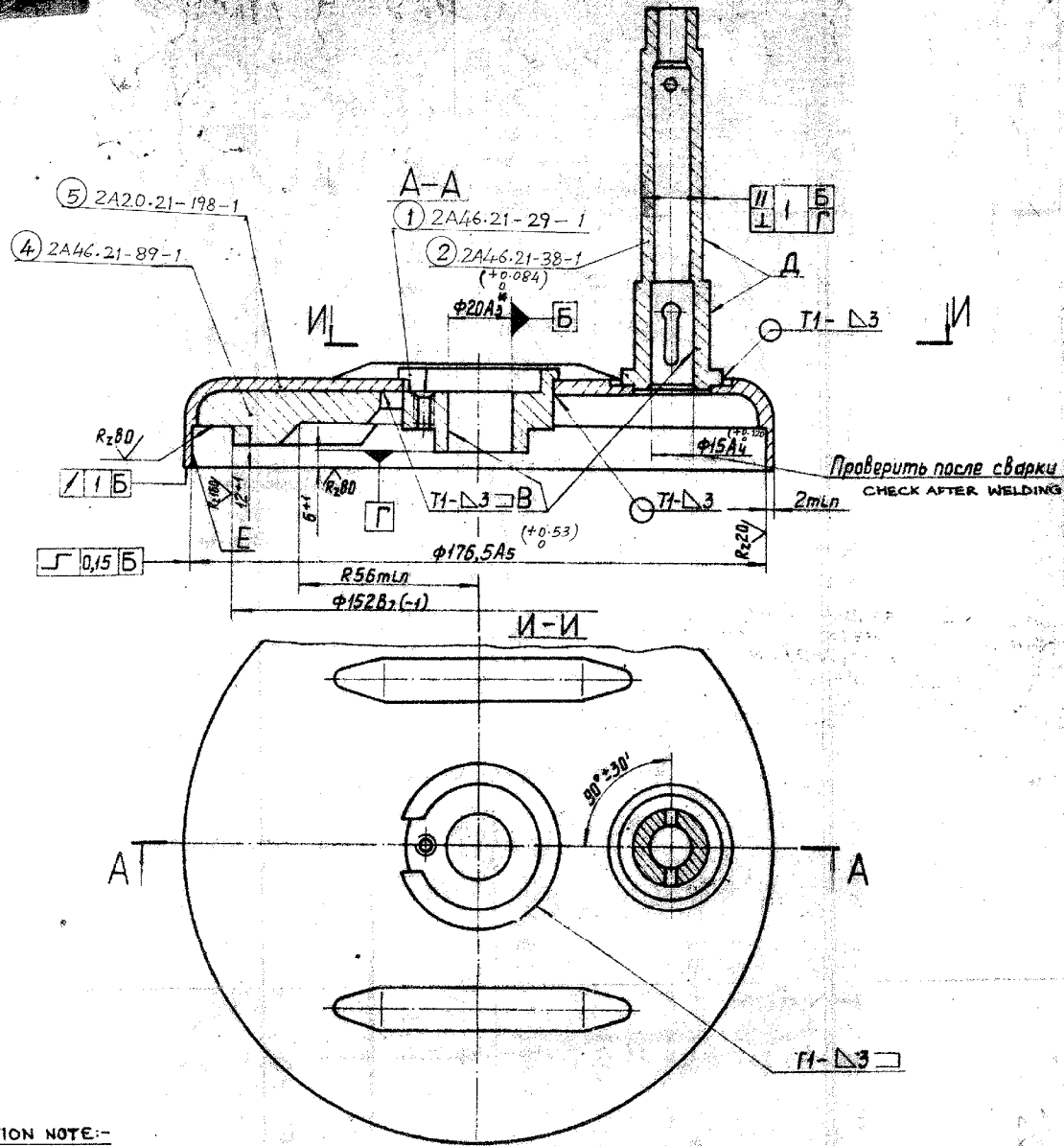

INSPECTION NOTE:-  
FOR LIST OF GAUGES AND FIXTURES REFER  
GAUGE SHT.No.GS(W)-10037 SHT.1.

1. Welds as per GOST 5264-80.
2. All welds of 3rd category as per OST 3-4001-77.
3. Coating: chemical phosphating, chromium  
primer ГФ -0163 (2 layers)  
enamel ХВ-518, khaki (2 layers) IV.  
Except surfaces B, D and E.
4. Mark the index of the article and assembly no. on the tag.
5. \* Dimension for reference.

1. Сварные швы по ГОСТ 5264-80.
2. Все швы 3 категории по OST 3-4001-77.
3. Покрытие: Хим. фос. хр.  
Гр. ГФ-0163 (2)  
Эм. ХВ-518, защитный (2) IV,  
кроме поверхностей B, D и E
4. Маркировать индекс изделия и обозначение сборки на бирке.
5. \*Размер для справок.

120

5340-008526

2A46 C6 21-10C6

1874	1874	1874	1874
INSPECTION NOTE ADDED	INSPECTION NOTE ADDED	INSPECTION NOTE ADDED	INSPECTION NOTE ADDED
NEW SEALING CANCELLED AND TAG SEALED	NEW SEALING CANCELLED AND TAG SEALED	NEW SEALING CANCELLED AND TAG SEALED	NEW SEALING CANCELLED AND TAG SEALED
DRG SEATED PROY	DRG SEATED PROY	DRG SEATED PROY	DRG SEATED PROY

ISSUE DATE	REFERENCE	APPROVED	CHECKED	DRAWN	MATERIAL
HAND WHEEL					
Assembly drawing.					
SHEET	MAS	SCALE			
1 of 1	1:5	(1:1)			
C.O.A(AVA)AVRDA					

16313-W SCH SEALED PROV  
22-4-85

SIZE	ZONE	REF. No	PART No	NOMENCLATURE	Qty	REMARKS
				DOCUMENTS.		
			2A46- C 21-10CB	ASSEMBY DRAWING		
				COMPONENTS		
		1	2A46 . 21-29	HUB		1 PIECE MAY BE SUBSTITUTED BY ITEM-3
		2	2A46 . 21-38	HANDLE ROD.	1	
		3	2A46 . 21-47	HUB.		1 PIECE, USE INSTEAD OF ITEM-1
		4	2A46 21-89	COUNTER WEIGHT	1	
		5	2A20 21-198	HAND WHELL RIM	1	

SIGNATURE AND DATE

DUPLICATE INVENTORY No.

INSTEAD OF INVENTORY No.

SIGNATURE AND DATE

17068-W PROV, SEALING CANCELLED AND SCH SEALED  
7-5-91  
C/D

2A46 C 21-10 (54)

DESIGNER	CHECKED BY	INSPECTOR	SHEET No	No OF DOCUMENT	SIGNATURE	DATE

HAND WHEEL

LETTER	SHEET	No. OF SHEET
	1	2
CQA(W) JABALPUR		

SIZE	ZONE	REF. No.	PART No	NOMENCLATURE	Qty	REMARKS
				MATERIALS		
		7.		ELECTRODE 350A		
				GOST 9467-75		
		8.		BROWN PRIMER		
				ГО - 0163, OCT-6-10-49		
		9.		KHAKI ENAME XB-518		
				TY-6-10-966-75		

16313-W SCH SEALED PROV  
 22-4-85

ORIGINAL INVENTORY SIGNATURE AND DATE  
 INSTEAD OF INVENTORY No.  
 DUPLICATE INVENTORY No.  
 SIGNATURE AND DATE

17068-W PROV, SEALING CANCELLED  
 7-5-91 AND SCH SEALED  
 CID

2A46 - C 8 21 - 10

55