

(f) NOTE:
14/04/1997

BEFORE BULK PRODUCTION CHECK THE MATERIAL THROUGH TEST PIECE TO CONFIRM THE FOLLOWING PHYSICAL PROPERTIES/HARDNESS, REQUIRED FOR FINISHED COMPONENT.

MECHANICAL PROPERTIES:

1. YIELD STRESS \rightarrow 90 kg-f/mm²
2. REDUCTION OF AREA \rightarrow 30%
3. HARDNESS = 321 TO 387 BHN (BALL DIA. 5mm. LOAD 750 kg. LOADING TIME 10-15 SEC.)

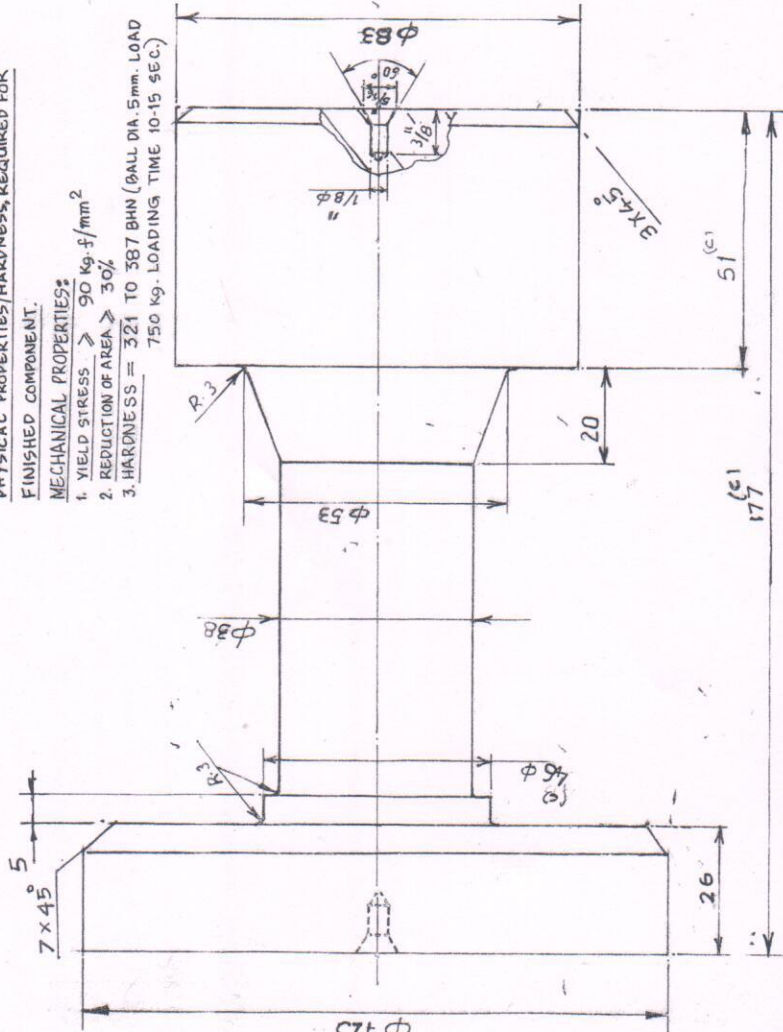

NOTE :-

1. COMP. TO BE FORGED ANNEALED TO 229 BHN (MAX)
2. COMP. TO BE ULTRASONICALLY TESTED AFTER ROUGH MACHINING.
3. PARALLELISM & CONCENTRICITY AS PER I.S. SPECN
4. COMP. TO BE SUPPLIED AS PER DRG-DIMN.
5. SURFACE FINISH ALLOWER - $\sqrt{10}$
6. GEN. TOLS. AS PER I.S. 2102 (MEDIUM)
7. SHARP EDGES TO BE REMOVED ϕ BY $0.5 \times 45^\circ$
8. DEPTH & SHAPE OF THE CENTRE SHOULD BE AS PER DRG.

(d) Place of Testing of Hardness" for portion on ϕ 35.5/88 upto 25 mm. from tapered portion.

Note: HARDNESS RANGE : 321 to 387 BHN. (Ball dia. 5mm. Load 750 kg. Loading Time 10-15 Sec.)

17C, DO/OFDC 30-01-92

DRG. AFTER ROUGH MACHINING FOR ULTRASONIC TEST

FOR- BODY OF STABILIZER

125-HEAT

MATL - STEEL - 45X1

GOST-B-10230-75

AMENDMENT

DATE ZONE DESCRIPTION

5.11.97 (see note deleted)

THIRD ANGLE PROJECTION

DIMENSIONS ARE IN mm.

UNSPECIFIED TOLS. IS : 2102 (MEDIUM)

TRACED BY -

DRAWN BY - *Chandra* 3-11-87

CHECKED BY - *Shy* 2/11/87

PASSED BY - *Shy* 2/11/87

APPROVED BY -

AMENDMENTS:
(a) DIMNS. 34 WAS 31, 50 WAS 53, TAPER ANGLE 20 DELETED & 20 ADDED & 127 WAS 123. - 2/11/87
(b) DIMNS. 27 WAS 34, STEPPING ϕ 48 ADDED, CENTER BOTH SIDES ADDED. CHAMF. 3x45 SHOW AT ϕ 85.
(c) DIMNS. 173 WAS 178, DIMN. 51 SHOWN & 123 DELETED. ϕ 40 WAS 48 & ϕ 123 WAS ϕ 124. - 17.5.90
(d) HARDNESS NOTE AND HARDNESS RANGE ADDED. 30-01-92.
(e) (d) NOTE DELETED.
(f) NOTE ADDED FOR MECHANICAL PROPERTIES: AUTHRY. DGM (CR&W) REF. TDS/OFDC LETTER NO. TDS/DEV-NPT/145 DTD. 15-12-92. *14/04/1997*

S/D. dt. 4/4/90.
F/DS
(SKETCH APPROVED)

LIST OF PARTS

ITEM	NO. OFF	MATERIAL	DESCRIPTION
COMPONENT:-			
ROUGH MACHINED DRG. FOR BODY 125 HEAT			
DRG. NO.	SCALE :- 1:1		
OFDC-SK-1559			
M/C.			
ORDNANCE FACTORY DUMDUM			
			NO. OF SHEETS-1
			SHEET NO.- 1

A.S. PER INSTRUCTION OF DGM (CR&W), ON 17.5.90. (Signature)