

DRAWING NO.
172.26.015-4/F

MODIFICATIONS & ADDITIONS		
ISSUE	MODIFICATIONS & 'N' OF 'A'	SIGN.
A	REDRAWN FOR CLEAR PRINTS	<i>N. S. S.</i>

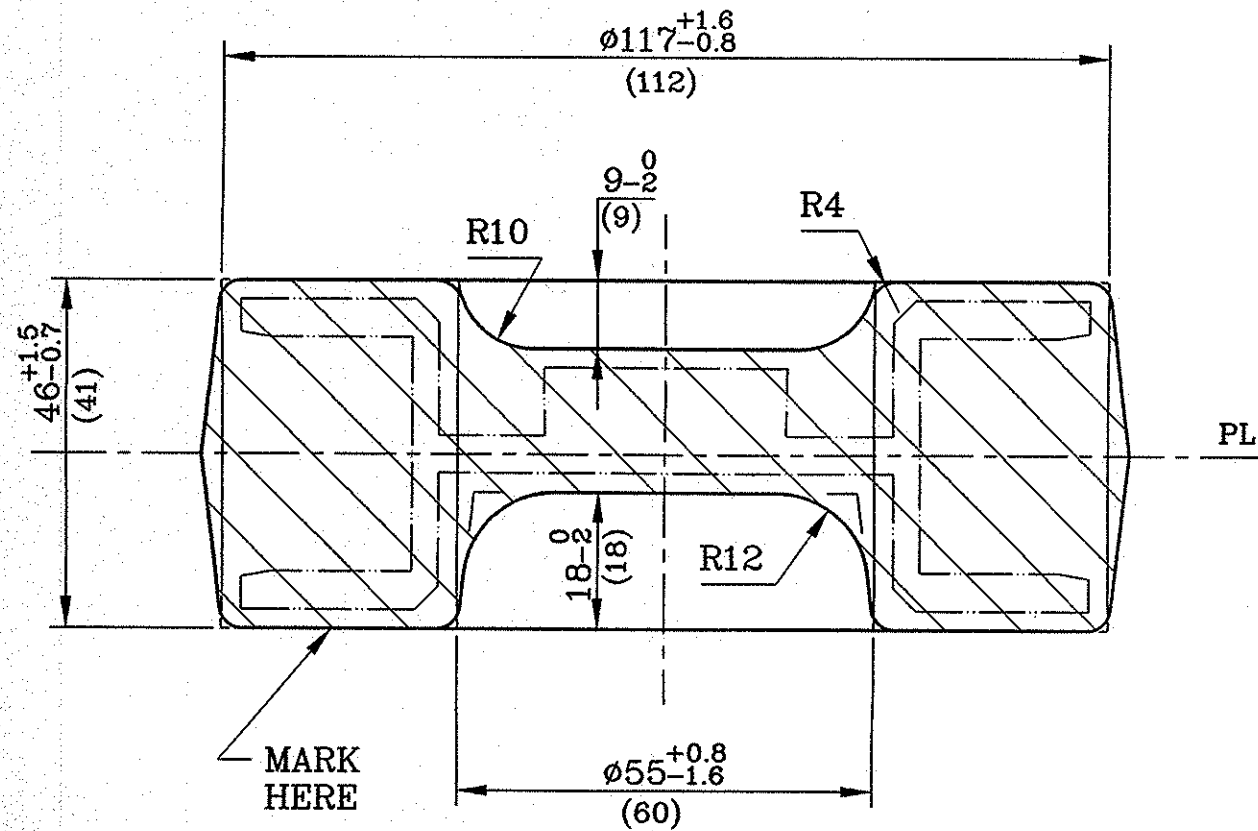

TOOL NO.	TOOL DESIGNATION	MACHINE	REMARKS
20295	TRIMMING TOOL	250 T	
20294	STAMPING DIES	MPM	

TECHNICAL REQUIREMENTS.

- | | |
|--|---|
| 01. HEAT TREAT. DIA. OF IND. \geq 3.8 MM | 06. UNSPECIFIED DRAFT = 7° |
| 02. DE-SCALE | 07. UNSPECIFIED RADII = R 3.0 MM. |
| 03. SURFACE DEFECTS AND SCALE PITS
UPTO 0.5 OF ACTUAL MACHINING ALLOWANCE
ARE ALLOWED. | 08. MARK PART NO. |
| 04. MISMATCH SHOULD NOT EXCEED 0.8 MM. | 09. MACHINING DIMENSIONS ARE SHOWN IN BRACKETS. |
| 05. RESIDUAL FIN ALONG THE PARTING LINE
SHOULD NOT EXCEED 1.0 MM. | 10. UNTOLERANCED DIMENSIONS ARE FOR CONSTRUCTION/
NOT TO BE CHECKED. |
| | 11. PAINT RED OXIDE. |

T-72

MATERIAL	FORGING WT.	
STEEL 38XC GOST 4543-71	3.73 KGS	
ALT. MATERIAL	HAMMER	SCALE
	MPM	1:1
DRAWN	CHECKED	APPROVED
<i>A. S. S. 13/10/07</i>	<i>A. S. S. 12/10/07</i>	<i>A. S. S. 13/10/07</i>
DRAWING NO. 172.26.015-4/F		
NOMENCLATURE: SPROCKET		
HEAVY VEHICLES FACTORY AVADI, CHENNAI		