

D.S. CAT No. 5330-382979
 DRG CONVENTIONS CONFORM TO IS : 696
 DIMNS ARE IN mm UNLESS OTHERWISE STATED
 TOLERANCE FOR UNTOLERANCED LINEAR DIMNS IS:2102 (MED CL)
 4 SHTS

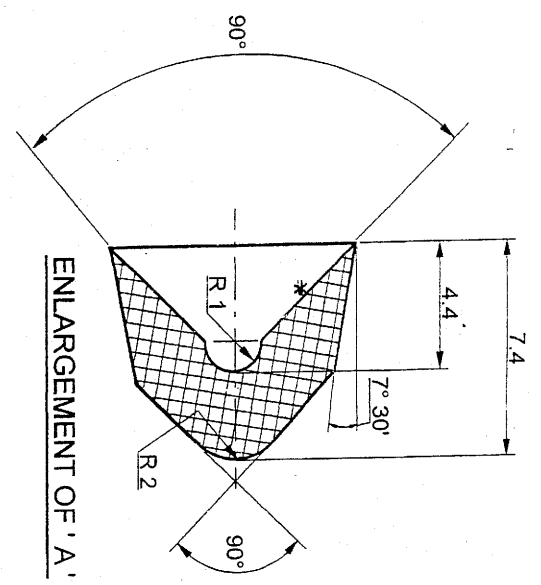
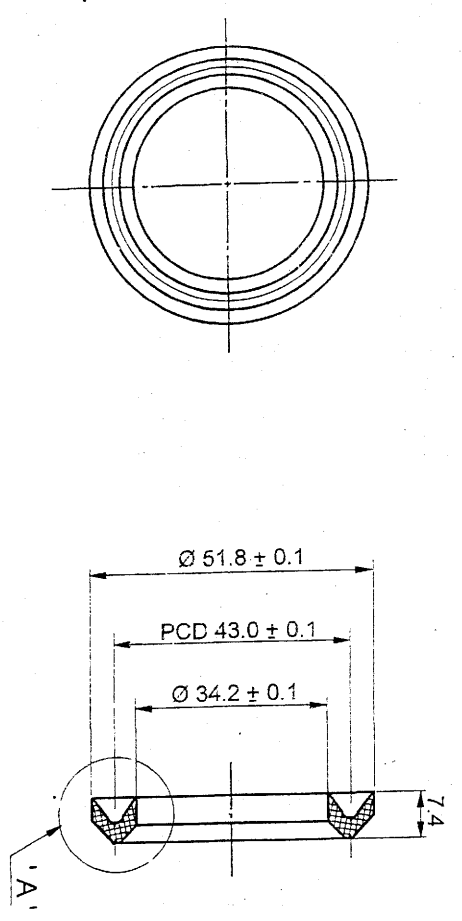

MANUFACTURER'S INITIAL BE EMBOSSED IN SUITABLE CHARACTERS, WHERE MARKED THUS *

MATERIAL :-
 1. ACRYLONITRILE BUTADIENE RUBBER COMPOUNDS TO SPEC JSS: 9320-24-2014 (REV. No. 1, DC 5361-ME DATED 28 JUL 2015) GRADE 'D'.
 2. FABRIC REFERENCE No. 2 TO SPEC BS : 1103 - 1989 WITH A SPECIAL REQUIREMENT OF ELONGATION AT BREAK 30% MAX IN BOTH WARP AND WEFT DIRECTIONS

NOTES :-
 1. RINGS TO BE MANUFACTURED & TASTED AS PER SPEC No. WPN / GEN / 9 (4) (1)
 2. HARDNESS ON THE FINISHED STORE 90° - 100° BS
 3. EXTENT OF CANVAS IN FINISHED STORE 40 TO 50 % AS PER CQA (ME) TEST METHOD No. CQA(ME)/LAB TEST METHOD/2015/01 DATED 29-10-15.

8-4-24	14716-W	ZONE (3-1) UNDER HEAD/DWG 'NOTES' AT SL No 1 AMENDED	DO	DO
7-12-15	19465-W	MATERIAL SL No 1 & NOTE SL No. 3 AMENDED	DO	DO
11-12-13		SCANNED & PRINTED WITHOUT CHANGE	DO	DO
DATE	AUTHORITY	ZONE	SIG. AMSP	SIG. DO
PREV DC Nos:- 17827-W, 18450-W, 18491-W, 18825-W, 18844-W & 19292-W DT 10-12-12				

DRAWN:-	CHD:-	ASSY DRG:-
SCANNED:- PKA	CHD:- GSN	DATE:-
HOS	AMSP	SCALE:- 1:1
MATERIAL:- AS SHOWN ABOVE	DO	ESTD M88S:-
PROTECTIVE FINISH:-		

CQA(W), JABALPUR	DESIGN No. C1 / WPN / 577
4 SHTS	PART No. IFL 8038
4 SHTS	DS CAT No. 5330-382979
4 SHTS	SHT 3

PACKING, PREFORMED OR PACKING

पैकिंग प्रीफार्मड और पैकिंग

DRG SEALED:- 18844-W DT 03-01-04

DO CQAW

4 SHTS

SHT 3

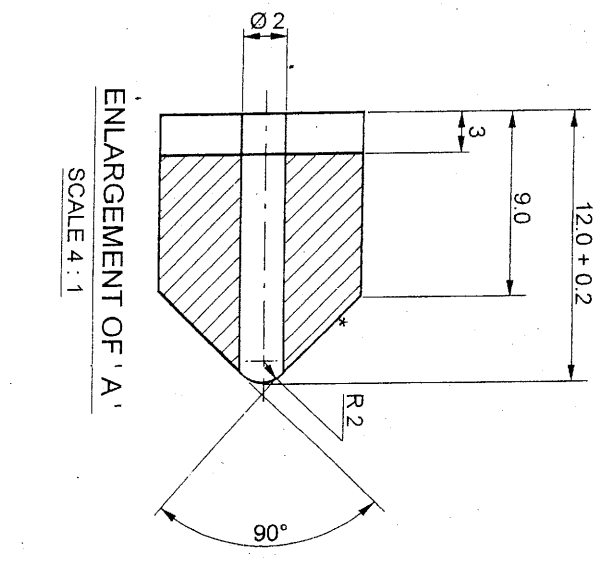
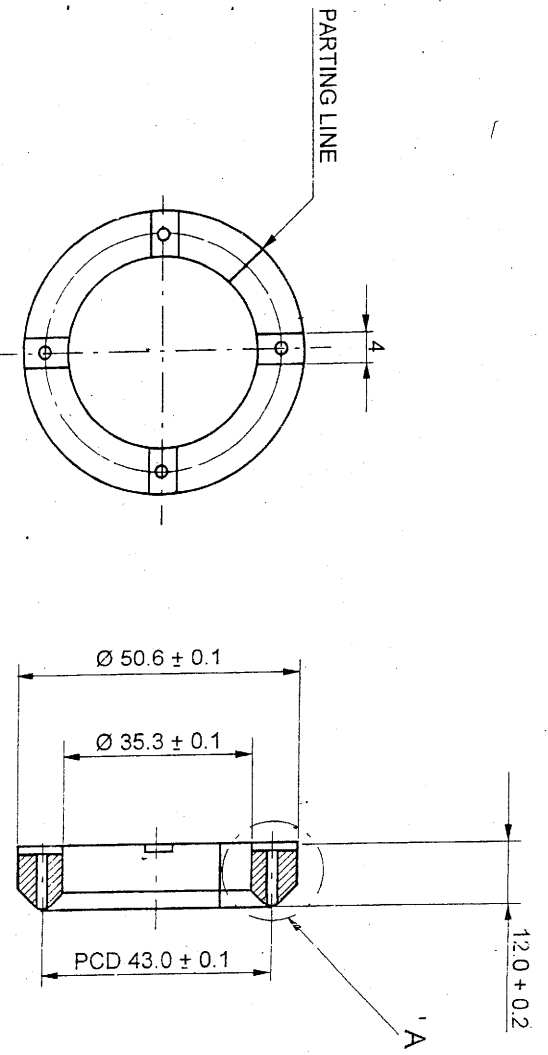

MATERIAL : NYLON 66 GP Moulding GRADE, COLOUR BLACK
 TO SPEC DEF STAN 93 - 8 / 1

NOTE : FINISHED STORE TO BE TESTED TO SPEC IA 1008 - A (D)
 MAUFACTURER'S INITIAL BE EMBOSSED IN SUITABLE CHARACTERS
 WHERE MARKED THUS *

DATE: 26-11-13		SCANNED & PRINTED WITHOUT CHANGE		DRAWN: CHD:-		ASSY DRG:-		COA(W), JABALPUR	
DATE: 26-11-13		SCANNED & PRINTED WITHOUT CHANGE		CHD:- G S N		DATE:-		DESIGN No. CI / WPN / 577	
AUTHORITY: ZONE		AMENDMENTS		AHSP		SCALE: 1 : 1 & 4 : 1		PART No. IFL 8038	
PREV DC Nos:- 17827-W, 18450-W, 18491-W, 18825-W, 18844-W & 19292-W DT 10-12-12		SIG. AHSP		DO		ESTD mass:-		DS CAT No. 5330-382979	
DRG SEALED:- 18844-W DT 03-01-04		DO COA(W)		PACKING, PREFORMED OR PACKING		PROTECTIVE FINISH:-		SHT 2	
DRG SEALED:- 18844-W DT 03-01-04		DO COA(W)		पैकिंग प्रीफॉर्मड ऑर पैकिंग		PROTECTIVE FINISH:-		SHT 2	

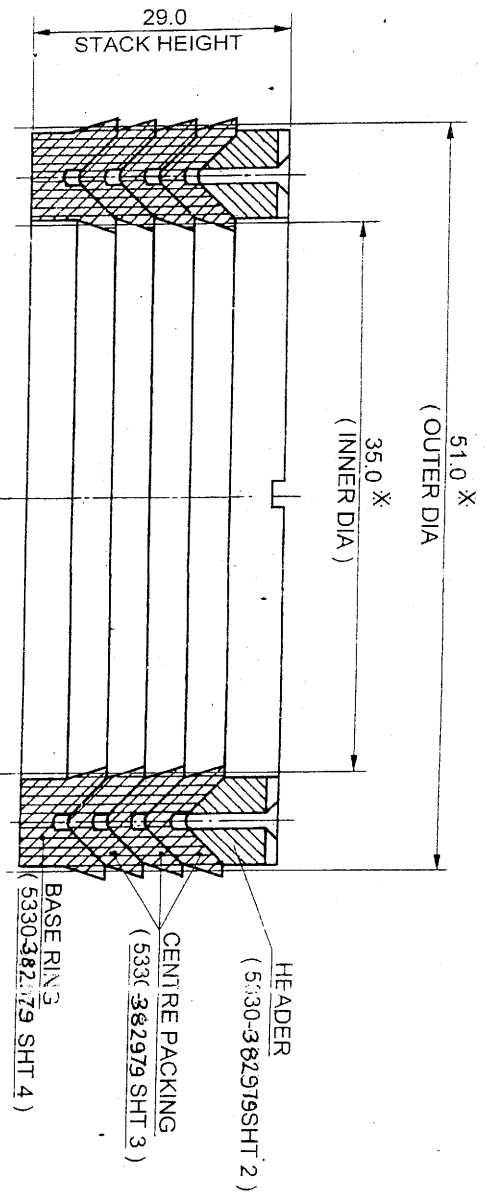

- NOTES:-
1. EACH SET OF PACKINGS SUPPORTED ON EITHER ENDS (HEADER & BASE RING) BY LIGHT CARD BOARD DISCS (CONTAINING THE FOLLOWING DETAILS) WILL BE PACKED IN A SEALED POLYTHENE BAG
 2. THE ABOVE SEALED BAG WILL BE HOUSED IN A SUITABLE CARTON (ENCLOSED WITH A LABEL CONTAINING THE DETAILS AS MENTIONED ABOVE) TO FACILITATE TRANSIT/ STORAGE
 3. THE CARTON WILL BE STAMPED WITH MANUFACTURER'S INITIAL AND PART No. OF THE PACKING OR A LABEL CONTAINING THESE DETAILS WILL BE PASTED OVER THE SAME

* NOMINAL MATING DIMENSIONS GIVEN FOR REFERENCE ONLY

1. MANUFACTURER'S INITIAL
2. BATCH / LOT No.
3. MONTH & YEAR OF MANUFACTURE

DRAWN:-		CHD:-	ASSY DRG:- 2590-001912 & 1015-003292	DESIGN No.		COA(W), JABALPUR	
SCANNED: PKA		CHD:- GSN	DATE:-	CI / WPN / 577		PART No.	
MATERIAL:-		AHSP	SCALE:-	FOR COA(W)		IFL 8038	
H.O.S		DO	ESTD mass:-	PROTECTIVE FINISH:-		DS CAT No.	
DO COA(W)		PACKING, PREFORMED OR PACKING		5330-382979		SHT 1	
PREV DC Nos:- 17827-W, 18450-W, 18491-W, 18524-W, 18925-W, 18944-W & 19292-W		Dt: 10-12-12		DRG SEALED:- 18844-W DT 03-01-04		SHT 1	

पैकिंग प्रीफार्मड ऑर पैकिंग



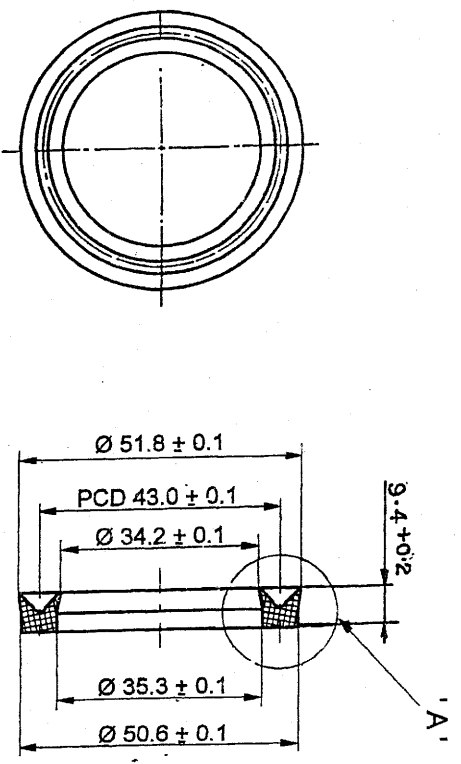

SCALE :- 1 : 1

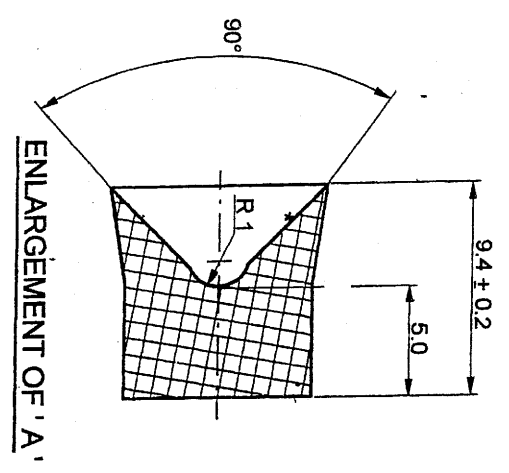

ENLARGEMENT OF 'A'

MATERIAL :-

1. ACRYLONITRILE BUTADIENE RUBBER COMPOUNDS TO SPEC JSS: 9320-24-2014 (REV: No. 1, DC 5361-ME DATED 28 JUL 2015) GRADE 'D'
2. FABRIC REFERENCE No. 2 TO SPEC BS : 1103 - 1989 WITH A SPECIAL REQUIREMENT OF ELONGATION AT BREAK 309% MAX IN BOTH WARP AND WEFT DIRECTIONS

NOTES :-

1. RINGS TO BE MANUFACTURED & TASTED AS PER SPEC No. WPN / GEN / 944 (1)
2. HARDNESS ON THE FINISHED STORE 90° - 100° BS
3. EXTENT OF CANVAS IN FINISHED STORE 40 TO 50 % AS PER CQA (ME) TEST METHOD No. CQA(ME)/LAB TEST METHOD/2015/01 DATED 29-10-15.

MANUFACTURER'S INITIAL BE EMBOSSED IN SUITABLE CHARACTERS, WHERE MARKED THUS *

18-4-19	1976-W	ZONE (3-1) UNDER HEADLINE	NOTES AT SL NO 1 AMENDED		
7-12-15	19465-W		MATERIAL SL No 1 & NOTE SL No. 3 AMENDED		
11-12-15			SCANNED & PRINTED WITHOUT CHANGE		
DATE	AUTHORITY	ZONE	AMENDMENTS	SIG. AHSP	SIG. DO
PREV DC Nos:- 17827-W, 18450-W, 18491-W, 18825-W, 18844-W & 19292-W DT 10-12-12					

DRAWN:-	CHD:-	ASSY DRG:-
SCANNED: PKA	CHD: GSN	DATE:-
H.O.S	DO	SCALE:-
MATERIAL: AS SHOWN ABOVE		
PROTECTIVE FINISH:-		

PACKING, PREFORMED OR PACKING

पैकिंग प्रीफार्मड ऑर पैकिंग



CQA(W), JABALPUR

DESIGN No.	CI / WPN / 577	SHT 4
FART No.	IFL 8038	SHT 4
4 SHTS		
DS CAT No.	5330-382979	SHT 4

DRG SEALED:- 18844-W DT 03-01-04