

SL. NO.	DRAWING NO.	NOMENCLATURE	QTY.	SL. NO.
1	0204 04 03 01 03 001 00AA	SLIDING BUCKLE	1	1
2	IS: 4727-1968- TYPE-2	STEEL GREY (COLOUR NO. 698 TO IS:5-2007) NYLON WEBBING 30.0WIDTH x 2.0 THICK x 170.0 LENGTH	1	2
3	IS: 4727-1968- TYPE-2	OLIVE GREEN (COLOUR NO. 220 TO IS:5-2007) NYLON WEBBING 30.0WIDTH x 1.0 THICK x 65.0 LENGTH	2	3

STRAP PULLING ASSEMBLY
0204 04 03 01 03 000 00AA

QRB AND STRAP PULLING ASSEMBLY
0204 04 03 00 01 000 00AA

1	IS: 4727-1968- TYPE-2	STEEL GREY (COLOUR NO. 698 TO IS:5-2007) NYLON WEBBING 30.0WIDTH x 2.0 THICK x 300.0 LENGTH	1	4
2	STD. COMPONENT	QUICK RELEASE BUCKLE (QRB)	1	5

3-POINT SLING FOR JVPC 5.56x30mm
0204 04 03 00 00 000 00AA

HOOK SLING ASSEMBLY
0204 04 03 00 02 000 00AA
(Qty-2Nos)

1	0204 04 03 00 02 001 00AA	HINGE HOUSING HOOK SLING	1	6
2	0204 04 03 00 02 002 00AA	HOOK SLING	1	7
3	0204 04 03 00 02 003 00AA	RING LOCKING PLUNGER HOOK SLING	1	8
4	0204 04 03 00 02 004 00AA	HOUSING HOOK SLING	1	9
5	0204 04 03 00 02 005 00AA	PIN HINGE HOOK SLING	1	10
6	0204 04 03 00 02 006 00AA	SPRING PLUNGER HOOK SLING	1	11
7	0204 04 03 00 02 007 00AA	PLUNGER HOOK SLING	1	12

1	0204 04 03 01 03 001 00AA	SLIDING BUCKLE	2	R-1
1	STD. COMPONENT IS: 4727-1968- TYPE-2	STEEL GREY (COLOUR NO. 698 TO IS:5-2007) NYLON WEBBING/ STRAP LENGTH 2200.0	1	13

3-POINT SLING TREE FOR JVPC 5.56X30mm

DESIGN AUTHORITY ARDE PUNE 411021	DRN. ANKIT DATE 14/03/19	CHD. <i>1602/19</i>
	APPD. DATE 14/03/19	
	SEALED DATE	For Director

GENERAL TOL.: FINE / MEDIUM / COARSE
 CLASS TO IS: 2102
 DRG. CONVENTIONS CONFIRM TO INDIAN STANDARDS
 DIMENSIONS ARE IN mm UNLESS OTHERWISE STATED.

1 2 3 4 5 6 7 8
 SS 0 0 0 0 0 0 0 0
 V 0 0 0 0 0 0 0 0
 C 0 0 0 0 0 0 0 0
 S 0 0 0 0 0 0 0 0
 SS 0 0 0 0 0 0 0 0
 CI 0 0 0 0 0 0 0 0
 DRG CD

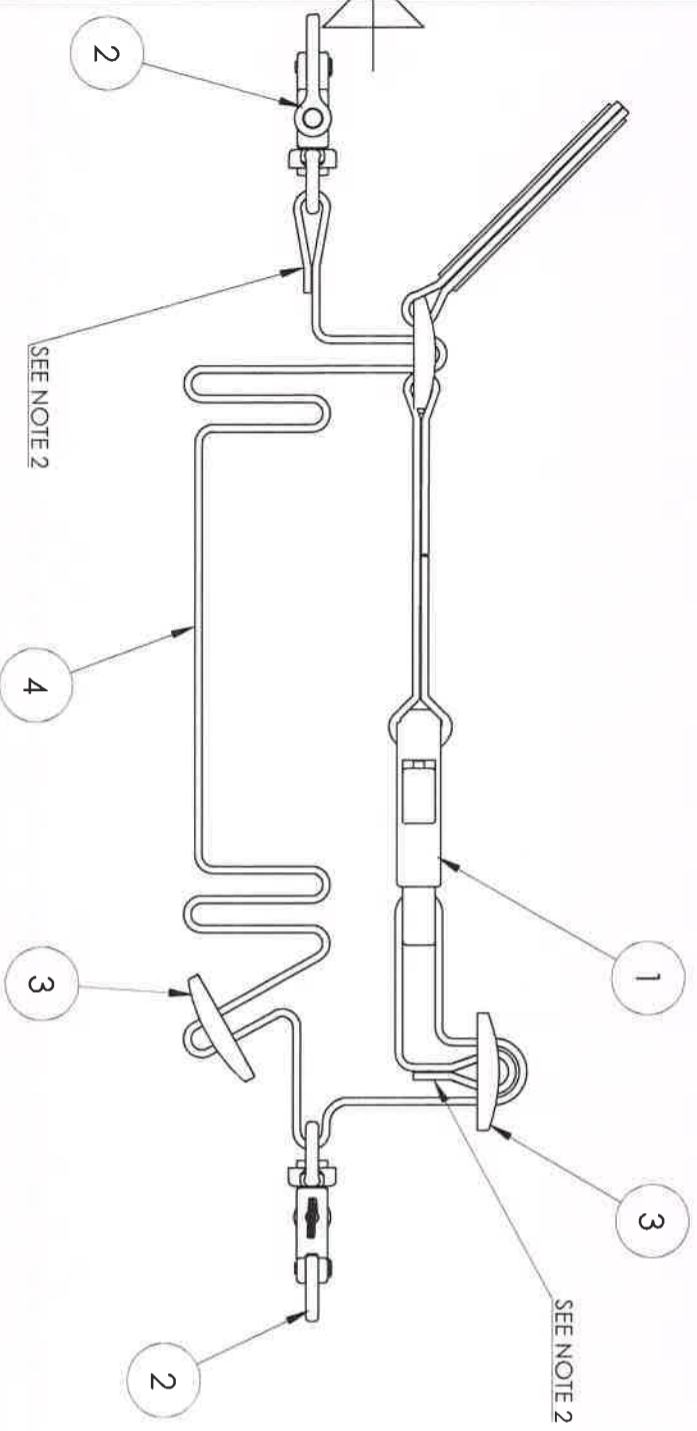
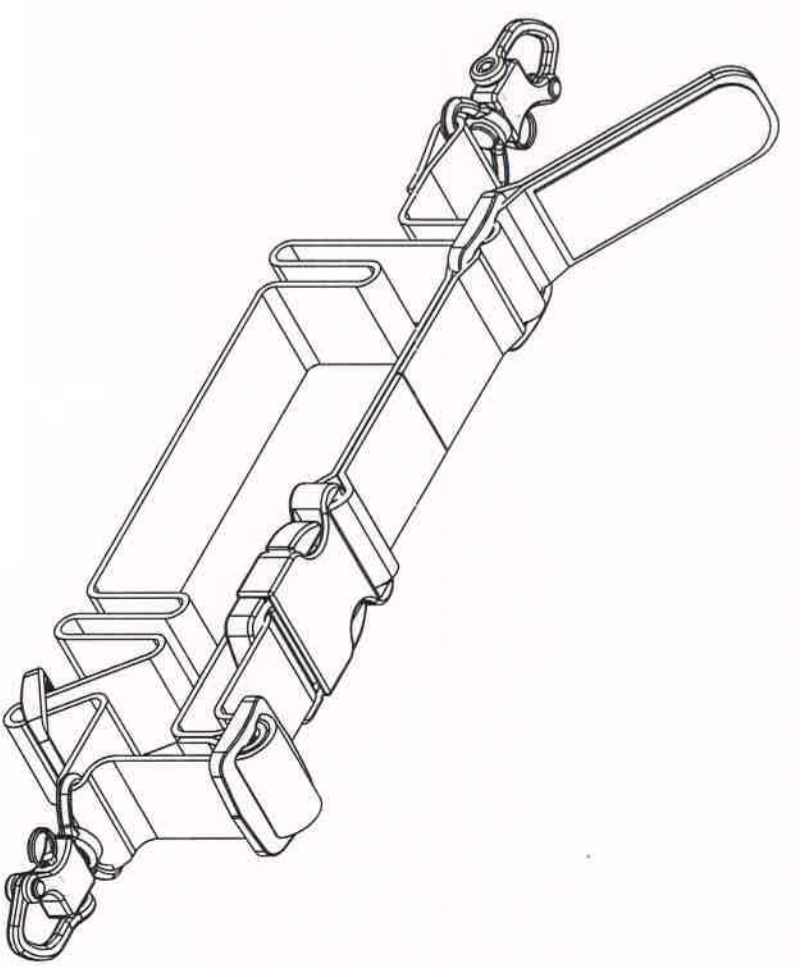
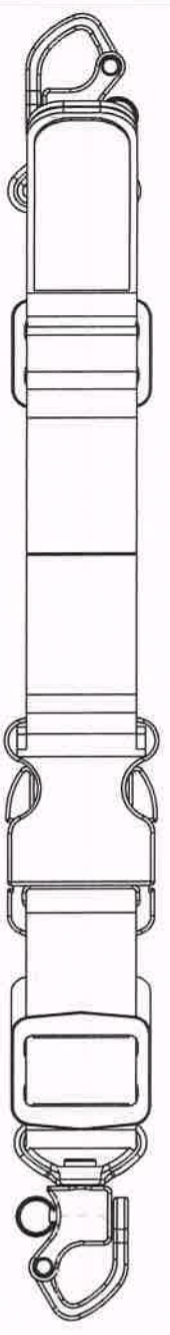

ITEM NO.	NOMENCLATURE	DESCRIPTION	QTY.
1	QRB AND STRAP PULLING ASSEMBLY	0204 04 03 00 01 000 00AA	1
2	HOOK SLING ASSEMBLY	0204 04 03 00 02 000 00AA	2
3	SLIDING BUCKLE	0204 04 03 01 03 001 00AA	2
4	STEEL GREY (COLOUR NO. 698 TO IS: 5-2007) NYLON WEBBING/ STRAP, LENGTH 2200.0	IS: 4727-1968-TYPE- 2	1

NOTE:-
 1) BOTH THE ENDS OF WEBBING TO BE HEAT SEALED
 2) STRAPS TO BE STITCHED IN TWO ROWS WITH STEEL GREY (COLOUR NO. 698 TO IS: 5-2007) NYLON THREAD TO IS: 4229
 3) REFER SPECIFICATION ARDE/SPECN/JVPC/2016/01 (PROV) FOR DETAILS OF WEBBING
 4) ASSEMBLY IS TO BE CARRIED OUT AS PER ASSEMBLY PROCEDURE NO. ARDE/JVPC/3-POINT SLING/ASSEMBLY PROCEDURE/2019/04

Sr. No.	DATE	AUTHORITY	MATERIAL:	BRIEF RECORD	ZONE	CD	GO
DRN: ANKIT	DATE: 14/03/2019	CHECKED	PROTECTIVE FINISH:				
SIGN: <i>Arde</i>							
DATE: 14/03/2019							
APPD.	DATE: 14/03/2019	FOR DIRECTOR					
SEALD							
DATE:							
SHEET SIZE: A3	EST. MASS	TITLE:	3-POINT SLING FOR JVPC 5.56X30mm				
SCALE: 1:1							
DESIGN AUTHORITY							
ARDE							
PUNE 411021							
DRG No.	0 2 0 4	0 4	0 3	0 0	0 0	0 0 0	0 0 A A
JVPC	IC	SS	S	AA	A	C	SS
PART No.			DS CAT No.			AHSP	

1	2	3	4	5	6	7	8
---	---	---	---	---	---	---	---

GENERAL TOL.: FINE / MEDIUM / COARSE
 CLASS TO IS: 2102
 DRG. CONVENTIONS CONFIRM TO INDIAN STANDARDS
 DIMENSIONS ARE IN mm UNLESS OTHERWISE STATED.

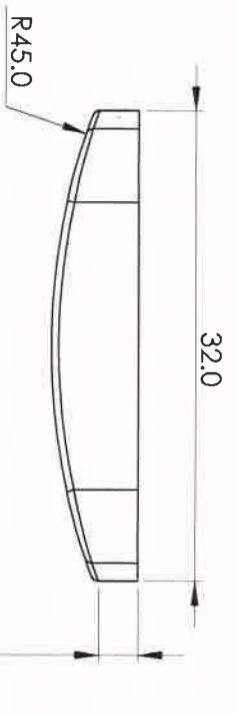
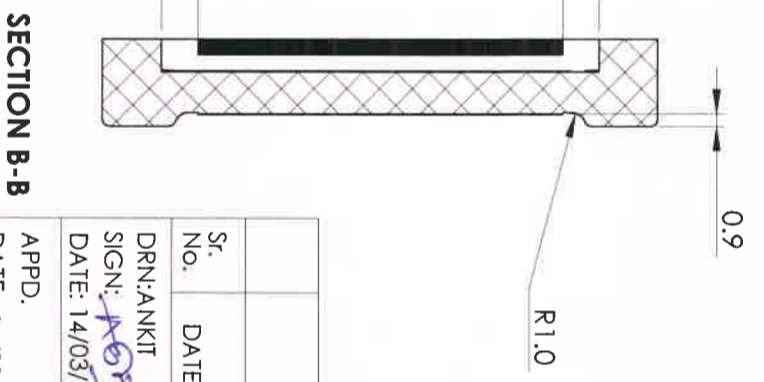
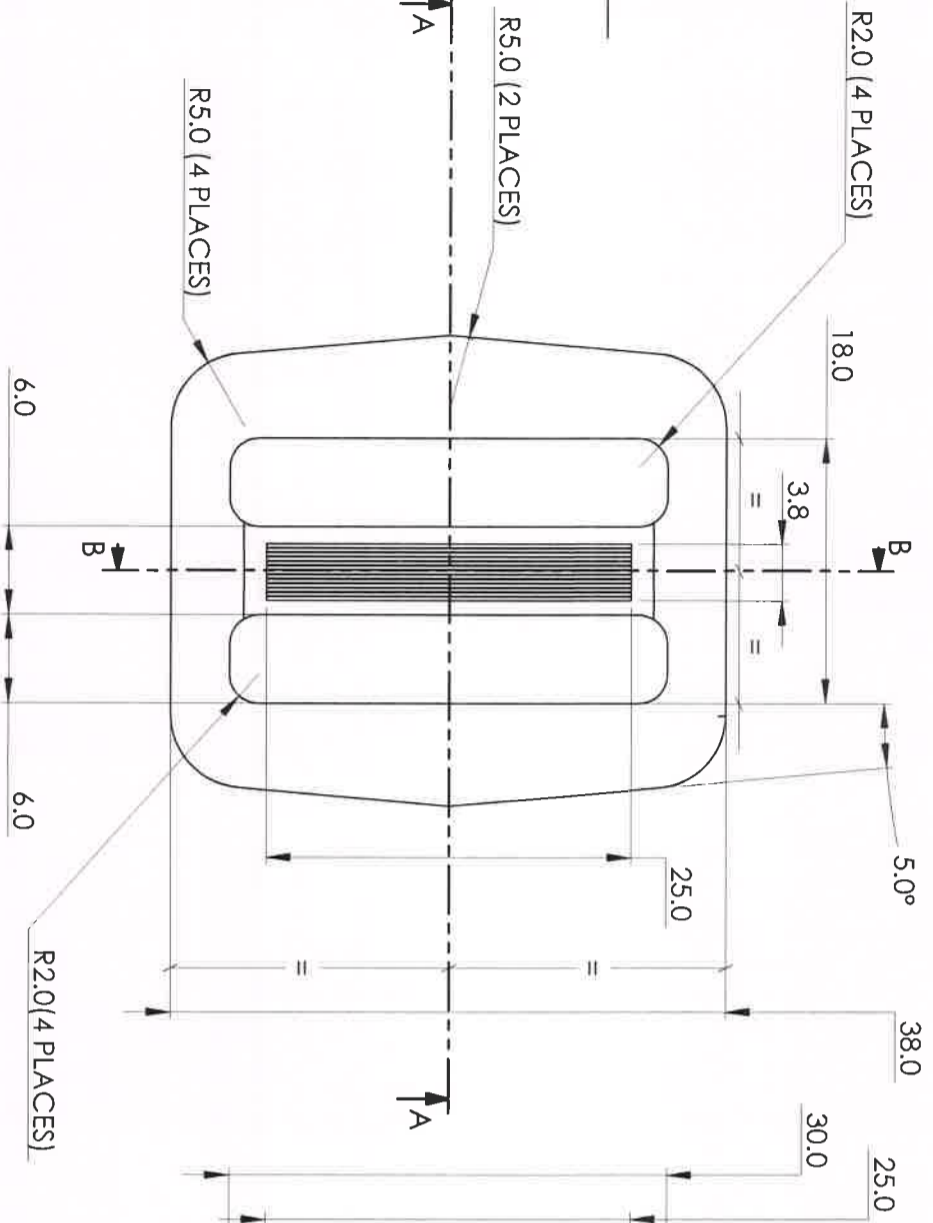
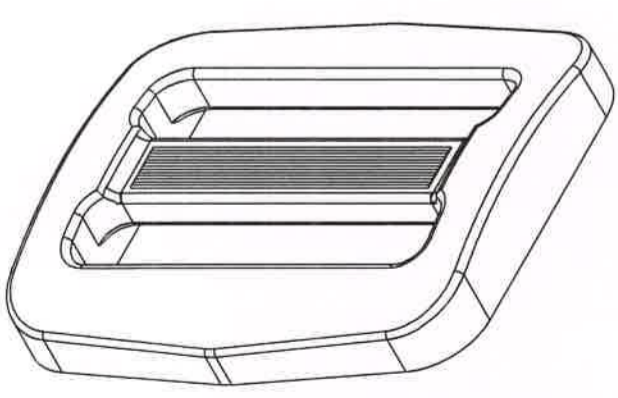
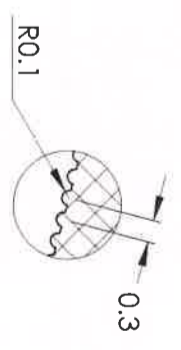
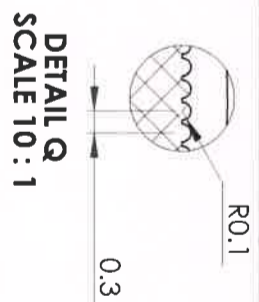
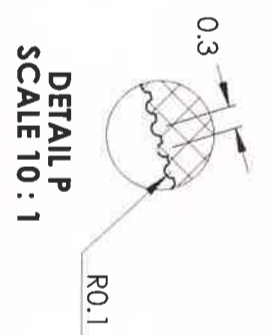
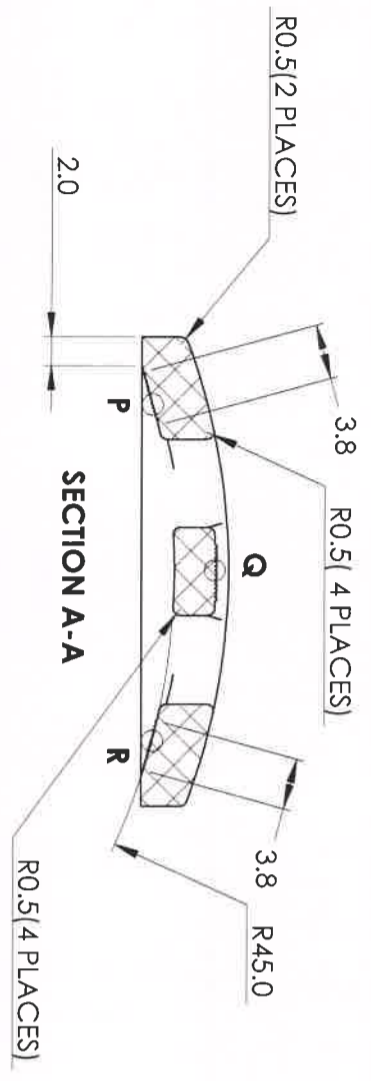

NOTES:-
 1) REMOVE ALL SHARP EDGES.
 2) COLOUR TO IS 5:2007, ISC No. 698 - STEEL GREY.
 3) ADDITION OF PIGMENT NOT PERMITTED.

Sr. No.	DATE	AUTHORITY	BRIEF RECORD	ZONE	CD	GO
DRN:ANKIT						
SIGN: <i>ANKIT</i>			MATERIAL:			
DATE: 14/03/2019			NYLON - 6,6: WITH 10% GLASS FILLED TO IS:13464:1992			
DATE: 14/03/2019		CHECKED	PROTECTIVE FINISH:			
APPD.						
DATE: 14/03/2019		FOR DIRECTOR				
SEALED						
DATE:						
SHEET SIZE: A3		EST. MASS	TITLE:			
SCALE: 2:1		4.28 gm	SLIDING BUCKLE			
DESIGN AUTHORITY						
ARDE						
PUNE 411021						
JVPC	PART No.	DS CAT No.	AHSP			
0204	04	03	001			
IC	SS	S	AA	A	C	SST
0204	04	03	01	03	001	00AA

1	2	3	4	5	6	7	8
---	---	---	---	---	---	---	---

1	2	3	4	5	6	7	8													
LSS		C		V		VV														
V	V	0	0	1	0	0	2	0	0	0	3	0	4	0	5	0	6	2	0	on GRD
GENERAL TOL. : FINE / MEDIUM / COARSE										DRG. CONVENTIONS CONFIRM TO INDIAN STANDARDS										
CLASS TO IS: 2102										DIMENSIONS ARE IN mm UNLESS OTHERWISE STATED.										

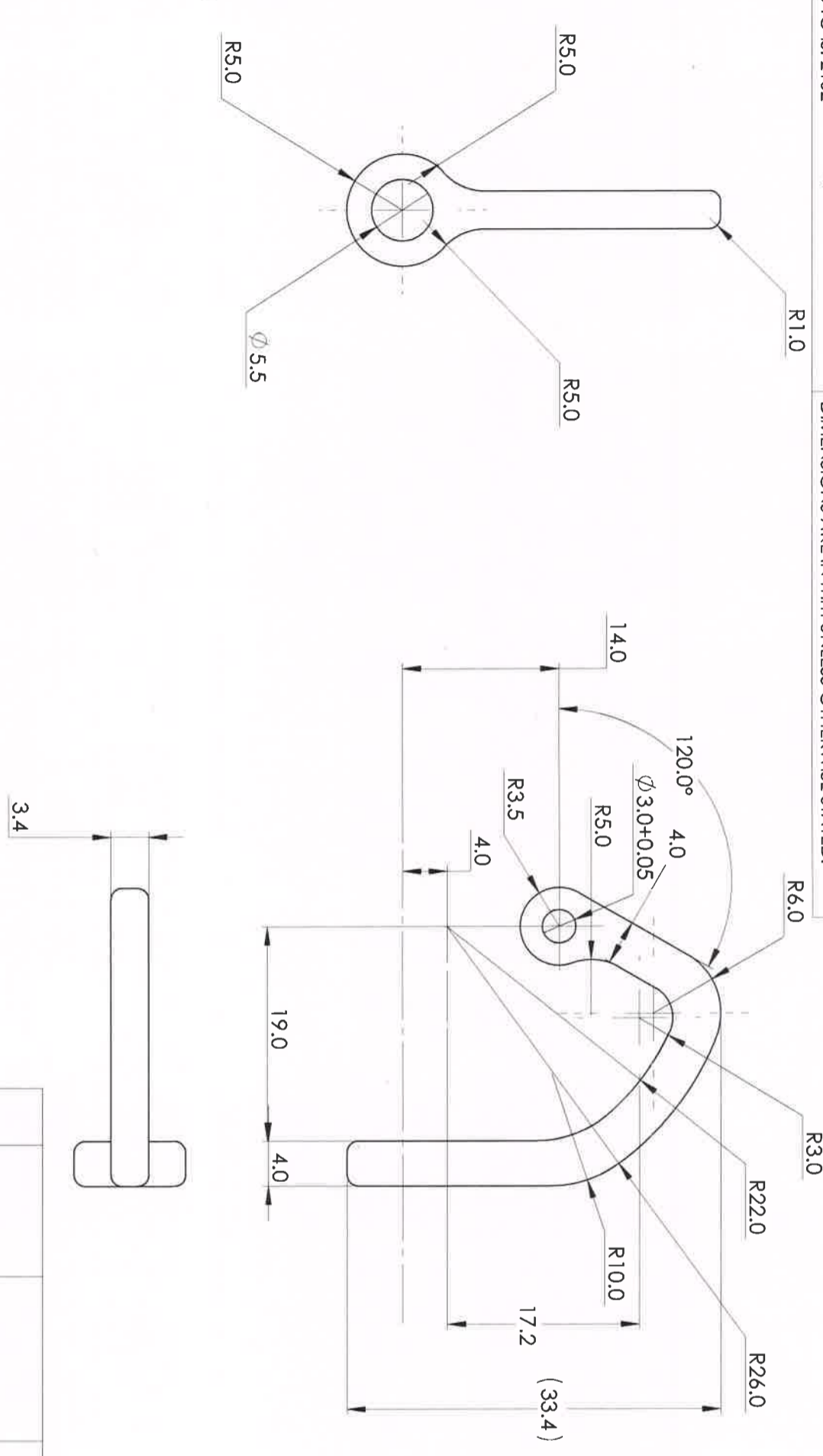

- NOTES:**
- 1) REMOVE ALL SHARP EDGES AND BURRS.
 - 2) HARDNESS: 325-375HV
 - 3) ALT. MATERIAL: STEEL TO BS 970 Pt-1: 1983 Gd.817M40 (EN-24)
 - 4) IF THE COMPONENT IS TO BE MANUFACTURED THROUGH MIM ROUTE, REFER ARDE SPECN. NO. DRDO/ARDE/MIM/TSP/051/2019
 - 5) ALT. PROTECTIVE COATING: ELECTROLESS NICKEL BORON COATING AS PER ARDE SPECN. NO. ARDE/SA/2016/COATING-03

Sr. No.		DATE		AUTHORITY		BRIEF RECORD		ZONE		CD		GO	
DRN: ANKIT		DATE: 14/03/2019		CHECKED		MATERIAL:		STEEL TO IS:5517-1993.Gd.-40Ni6Cr4Mo3					
SIGN: [Signature]		FOR DIRECTOR				PROTECTIVE FINISH:		ELECTROLESS NICKEL-BN COATING AS PER					
DATE: 14/03/2019		DATE:				ARDE SPECN. NO. ARDE/SA/2016/COATING-02							
APPD.		SHEET SIZE: A3		EST. MASS		TITLE:		HINGE HOUSING HOOK SLING					
DATE: 14/03/2019		SCALE: 1:1		6.5 gm		DESIGN AUTHORITY		ARDE					
SEALED		PUNE 411021		IC		SS		S		AA		A	
DATE:		DRG No. 0 2 0 4		0 4		0 3		0 0		0 2		0 0 1	
		JVPC		PART No.		DS CAT No.		AHSP					

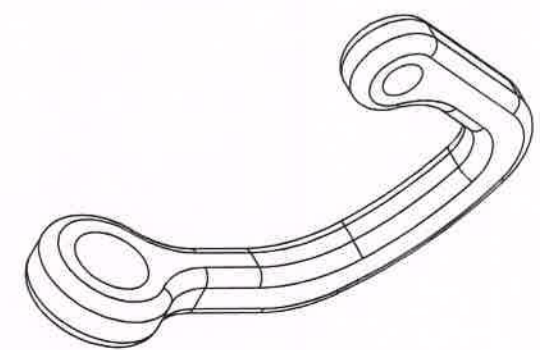

GENERAL TOL. : FINE / MEDIUM / COARSE
 CLASS TO IS: 2102
 DRG. CONVENTIONS CONFIRM TO INDIAN STANDARDS
 DIMENSIONS ARE IN mm UNLESS OTHERWISE STATED.

1 2 3 4 5 6 7 8
 I S S C A V V V S S S I
 0 0 0 2 0 0 2 0 0 0 0 0 4 0 4 0 2 0
 A V 0 0 2 0 0 0 0 0 0 0 0 4 0 2 0
 DRG GRD

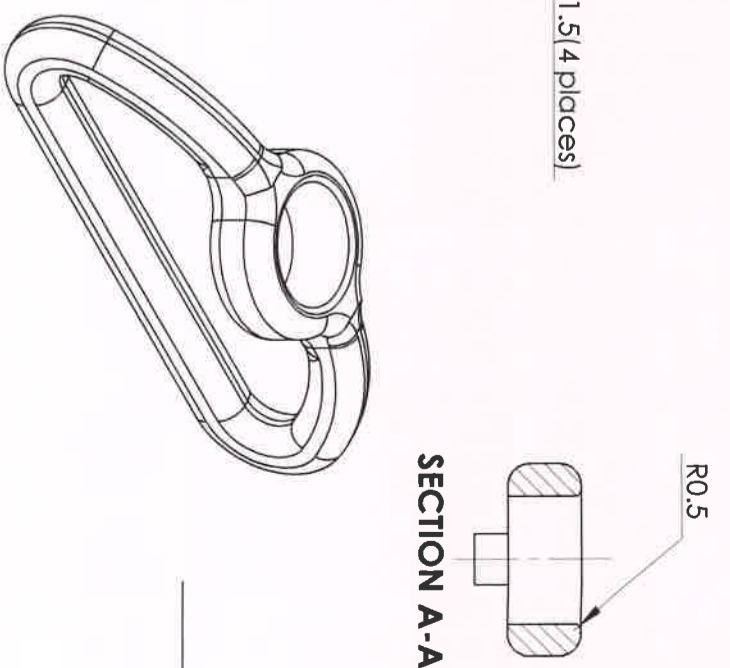
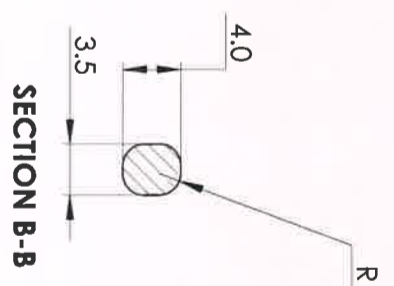
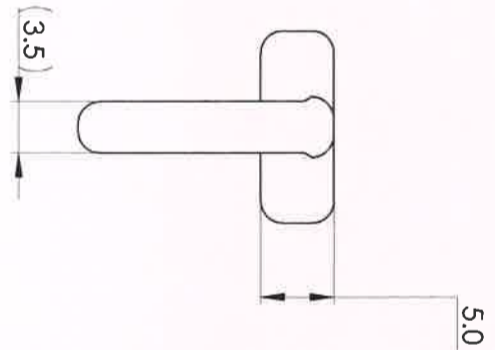
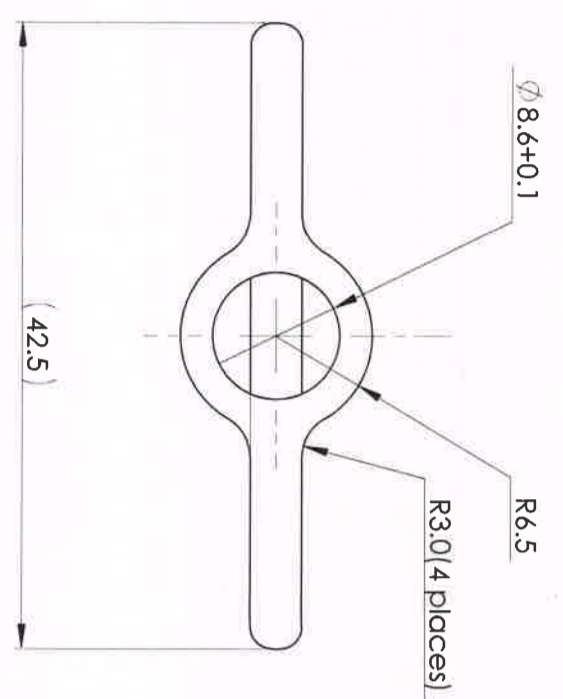
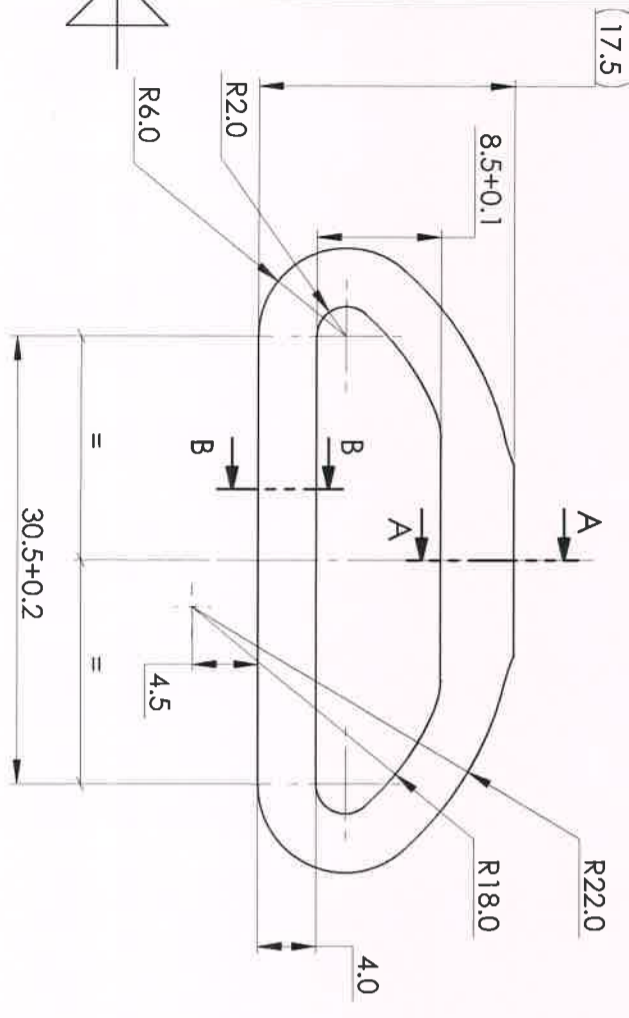

- NOTES:**
- 1) REMOVE ALL SHARP EDGES AND BURRS.
 - 2) HARDNESS: 260-310 HV
 - 3) IF THE COMPONENT IS TO BE MANUFACTURED THROUGH MIM ROUTE, REFER ARDE SPECN. NO. DRDO/ARDE/MIM/TSP/051/2019
 - 4) ALT. PROTECTIVE COATING: ELECTROLESS NICKEL BORON COATING AS PER ARDE SPECN. NO. ARDE/SA/2016/COATING-03

Sr. No.	DATE	AUTHORITY	MATERIAL:	BRIEF RECORD	ZONE	CD	GO
DRN: ANKIT	14/03/2019	<i>[Signature]</i>	STEEL TO IS: 5517-1993; Gd-40Ni6Cr4Mo3				
SIGN: <i>[Signature]</i>	14/03/2019	CHECKED	PROTECTIVE FINISH:				
DATE: 14/03/2019		<i>[Signature]</i>	ELECTROLESS NICKEL-BN COATING AS PER				
SEALING		FOR DIRECTOR	ARDE SPECN. NO. ARDE/SA/2016/COATING-02				
DATE:			TITLE:				
SHEET SIZE: A3			HOOK SLING				
SCALE: 2:1							
EST. MASS							
9.9 gm							
DESIGN AUTHORITY							
ARDE							
PUNE 411021							
DRG No.	0 2 0 4	0 4	0 3	0 0	0 2	0 0 2	0 0 A A
JVPC	IC	SS	S	AA	A	C	SST
PART No.			DS CAT No.			AHSP	

1	2	3	4	5	6	7	8
---	---	---	---	---	---	---	---

1	2	3	4
SS	C	A	VV
A 0 0	4 0 0	2 0	0 0
			S
			SS
			CI
			on GRD

GENERAL TOL.: FINE / MEDIUM / COARSE
 CLASS TO IS: 2102
 DRG. CONVENTIONS CONFIRM TO INDIAN STANDARDS
 DIMENSIONS ARE IN mm UNLESS OTHERWISE STATED.

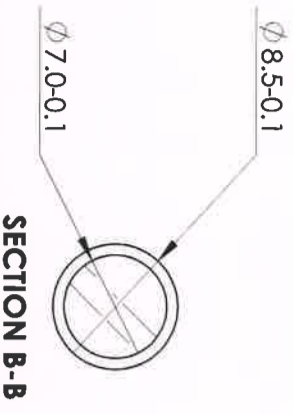
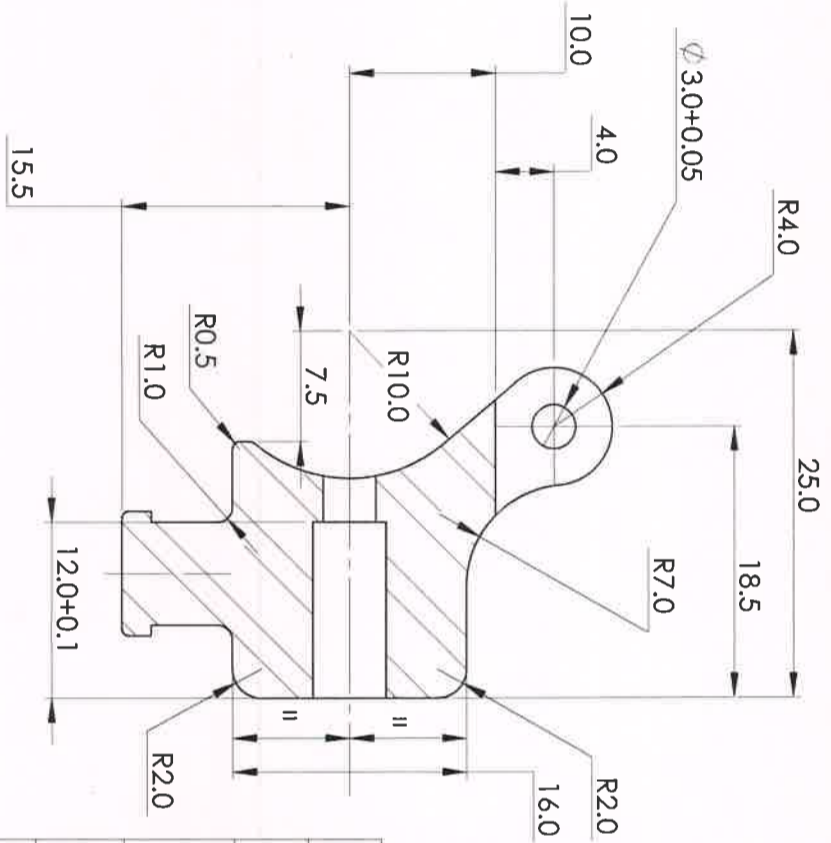
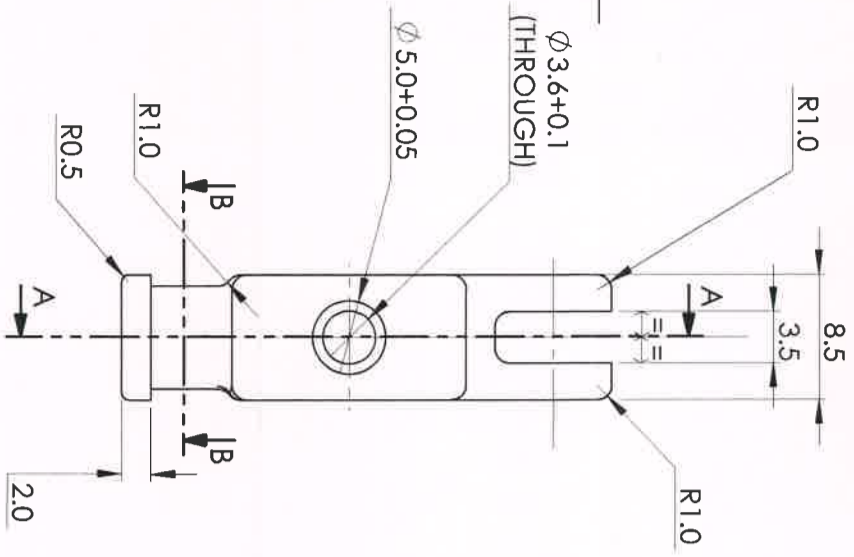
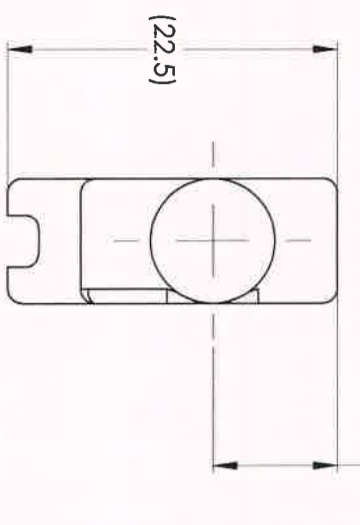

NOTES:

- 1) REMOVE ALL SHARP EDGES AND BURRS.
- 2) HARDNESS: 325-375HV
- 3) ALT. MATERIAL: STEEL TO BS 970 Pt-1: 1983 Gd.817M40 (EN-24)
- 4) IF THE COMPONENT IS TO BE MANUFACTURED THROUGH MIM ROUTE, REFER ARDE SPECN. NO. DRDO/ARDE/MIM/TSP/051/2019
- 5) ALT. PROTECTIVE COATING: ELECTROLESS NICKEL BORON COATING AS PER ARDE SPECN. NO. ARDE/SA/2016/COATING-03

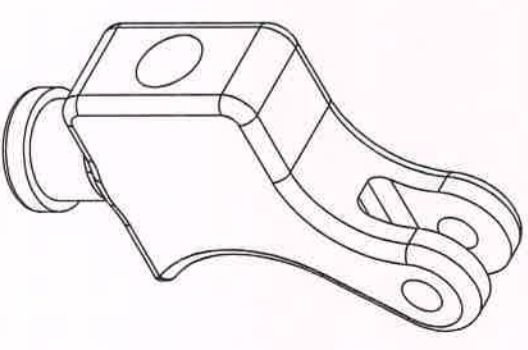

Sr. No.	DATE	AUTHORITY	BRIEF RECORD	ZONE	CD	GO
DRN: ANKIT						
SIGN: <i>Ankit</i>		<i>For Director</i>	MATERIAL:			
DATE: 14/03/2019		CHECKED	STEEL TO IS:5517-1993,Gd-40Ni6Cr4Mo3			
APPD.			PROTECTIVE FINISH:			
DATE: 14/03/2019			ELECTROLESS NICKEL-BN COATING AS PER			
SEALED			ARDE SPECN. NO. ARDE/SA/2016/COATING-02			
DATE:			TITLE:			
SHEET SIZE: A3		EST. MASS	HOUSING HOOK SLING			
SCALE: 1:1		20.07 gm				
DESIGN AUTHORITY						
ARDE						
PUNE 411021						
DRG No.	0 2 0 4	IC	0 4	SS	0 3	AA
JVPC	0 2 0 4	SS	0 4	S	0 0	AA
PART No.	0 2 0 4	SS	0 4	S	0 2	A
DS CAT No.	0 2 0 4	SS	0 4	S	0 0	A
AHSP	0 2 0 4	SS	0 4	S	0 0	A

1	2	3	4
ISS A A 0 0	C 5 0 0	A 2 0	AA 0 0
C 3 0	SS 4 0	IC 4 0 2 0	DRG No.

GENERAL TOL. : FINE / MEDIUM / COARSE CLASS TO IS: 2102 ✓ DRG. CONVENTIONS CONFIRM TO INDIAN STANDARDS DIMENSIONS ARE IN mm UNLESS OTHERWISE STATED.

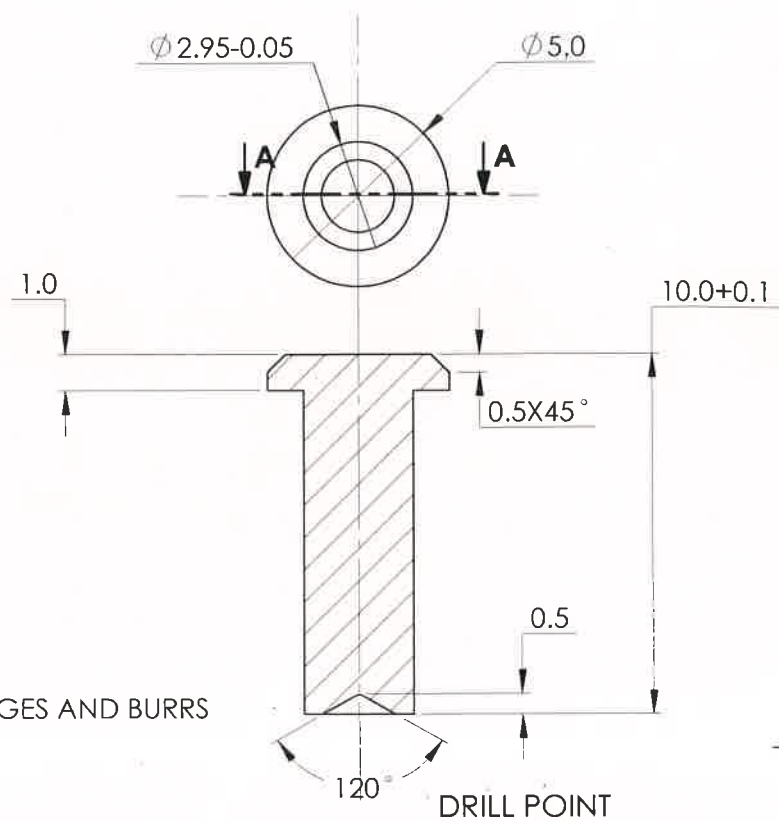

NOTES:-
 1) REMOVE ALL SHARP EDGES AND BURRS
 2) HARDNESS: 260-310HV

SECTION A-A

Sr. No.	DATE	AUTHORITY	BRIEF RECORD	ZONE	CD SIGN	GO SIGN
---------	------	-----------	--------------	------	---------	---------

DRN: ANKIT
 SIGN: *Ankit* *10/03/2019*
 DATE: 14/03/2019 CHECKED

MATERIAL:
 STEEL TO IS:5517-1993 ,Gd-55C8

APPD.
 DATE: 14/03/2019 FOR DIRECTOR *[Signature]*
 SEALED DATE:

PROTECTIVE FINISH:
 PHOSPHATED TO SPECN. IS:3618-1966, CLASS 'B'

SHEET SIZE: A4
 SCALE: 5:1
 EST. MASS: 0.6 gm

TITLE:
PIN HINGE HOOK SLING

DESIGN AUTHORITY
ARDE
 PUNE 411021

DRG No.	0 2 0 4	0 4	0 3	0 0	0 2	0 0 5	0 0 A A
	IC	SS	S	AA	A	C	SST
JVPC	PART No.	DS CAT No.	AHSP				

1	2	3	4
---	---	---	---

1	2	3	4
SS A A 0 0	C 9 0 0	A 2 0	AA 0 0
C 3 0	SS 4 0	IC 4 0 2 0	DRG No.

GENERAL TOL. : FINE / MEDIUM / COARSE CLASS TO IS: 2102 DRG. CONVENTIONS CONFIRM TO INDIAN STANDARDS DIMENSIONS ARE IN mm UNLESS OTHERWISE STATED.

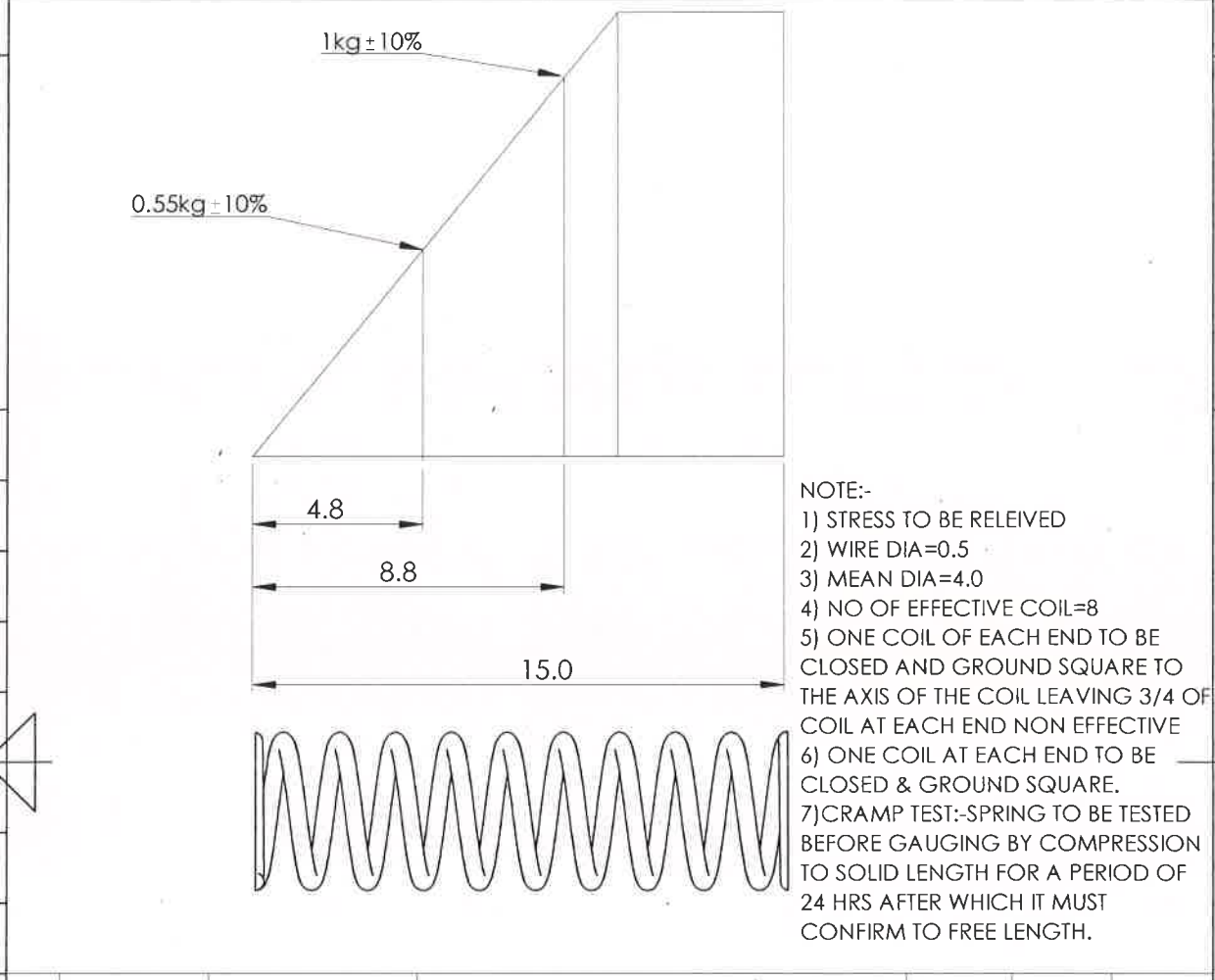

Sr. No.	DATE	AUTHORITY	BRIEF RECORD	ZONE	CD	GO
					SIGN	

DRN: ANKIT
SIGN: *[Signature]*
DATE: 14/03/2019 CHECKED *[Signature]*
MATERIAL: STEEL TO IS:4454(Pt-1),2001,DH

APPD. *[Signature]*
DATE: 14/03/2019 FOR DIRECTOR
PROTECTIVE FINISH: PHOSPHATED TO SPECN. IS:3618-1966, CLASS 'B'
SEALED DATE:

SHEET SIZE: A4 EST. MASS 0.2 gm
SCALE: 1:1
DESIGN AUTHORITY
ARDE
PUNE 411021
TITLE: **SPRING PLUNGER HOOK SLING**

DRG No.	0 2 0 4	0 4	0 3	0 0	0 2	0 0 6	0 0 A A
	IC	SS	S	AA	A	C	SST
JVPC	PART No.	DS CAT No.	AHSP				

1	2	3	4
---	---	---	---

DRG No. IC 0204 00700 SS 0404 C 0300 AA 0020 C 00700 ISS 000000

GENERAL TOL. : FINE / MEDIUM / COARSE
CLASS TO IS: 2102

DRG. CONVENTIONS CONFIRM TO INDIAN STANDARDS
DIMENSIONS ARE IN mm UNLESS OTHERWISE STATED.

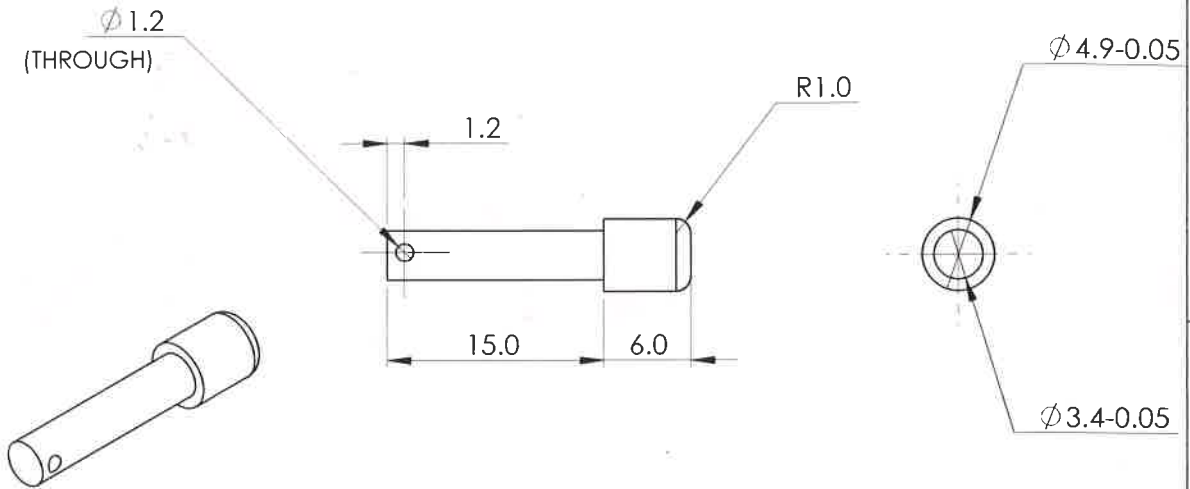

NOTES:

- 1) REMOVE ALL SHARP EDGES AND BURRS.
- 2) HARDNESS: 325-375HV
- 3) ALT. MATERIAL: STEEL TO BS 970 Pt-1: 1983 Gd.817M40 (EN-24)
- 4) IF THE COMPONENT IS TO BE MANUFACTURED THROUGH MIM ROUTE, REFER ARDE SPECN. No. DRDO/ARDE/MIM/TSP/051/2019
- 5) ALT. PROTECTIVE COATING: ELECTROLESS NICKEL BORON COATING AS PER ARDE SPECN. No. ARDE/SA/2016/COATING-03

Sr. No.	DATE	AUTHORITY	BRIEF RECORD	ZONE	CD	GO
					SIGN	

DRN: ANKIT
SIGN: *ANANT*
DATE: 14/03/2019 CHECKED *ANANT*

MATERIAL:
STEEL TO IS:5517-1993,Gd-40Ni6Cr4MO3

APPD. *[Signature]*
DATE: 14/03/2019 FOR DIRECTOR

PROTECTIVE FINISH:
ELECTROLESS NICKEL-BN COATING AS PER
ARDE SPECN. No. ARDE/SA/2016/COATING-02

SHEET SIZE: A4 EST. MASS
SCALE: 2:1 1.9 gm

TITLE:
PLUNGER HOOK SLING

DESIGN AUTHORITY
ARDE
PUNE 411021

DRG No. 0204 00700 SS 0404 C 0300 AA 0020 C 00700 00AA

IC SS S AA A C SST

JVPC PART No. DS CAT No. AHSP

GENERAL TOL.: FINE / MEDIUM / COARSE
 CLASS TO IS: 2102

DRG. CONVENTIONS CONFIRM TO INDIAN STANDARDS
 DIMENSIONS ARE IN mm UNLESS OTHERWISE STATED.

1 2 3 4 5 6 7 8
 SS 0 0 0 0 0 0 0 0
 A 0 0 0 0 0 0 0 0
 V 0 0 0 0 0 0 0 0
 C 0 0 0 0 0 0 0 0
 Y 0 0 0 0 0 0 0 0
 VV 0 0 0 0 0 0 0 0
 S 0 0 0 0 0 0 0 0
 SS 0 0 0 0 0 0 0 0
 CI 0 0 0 0 0 0 0 0
 DRG CD 0 0 0 0 0 0 0 0

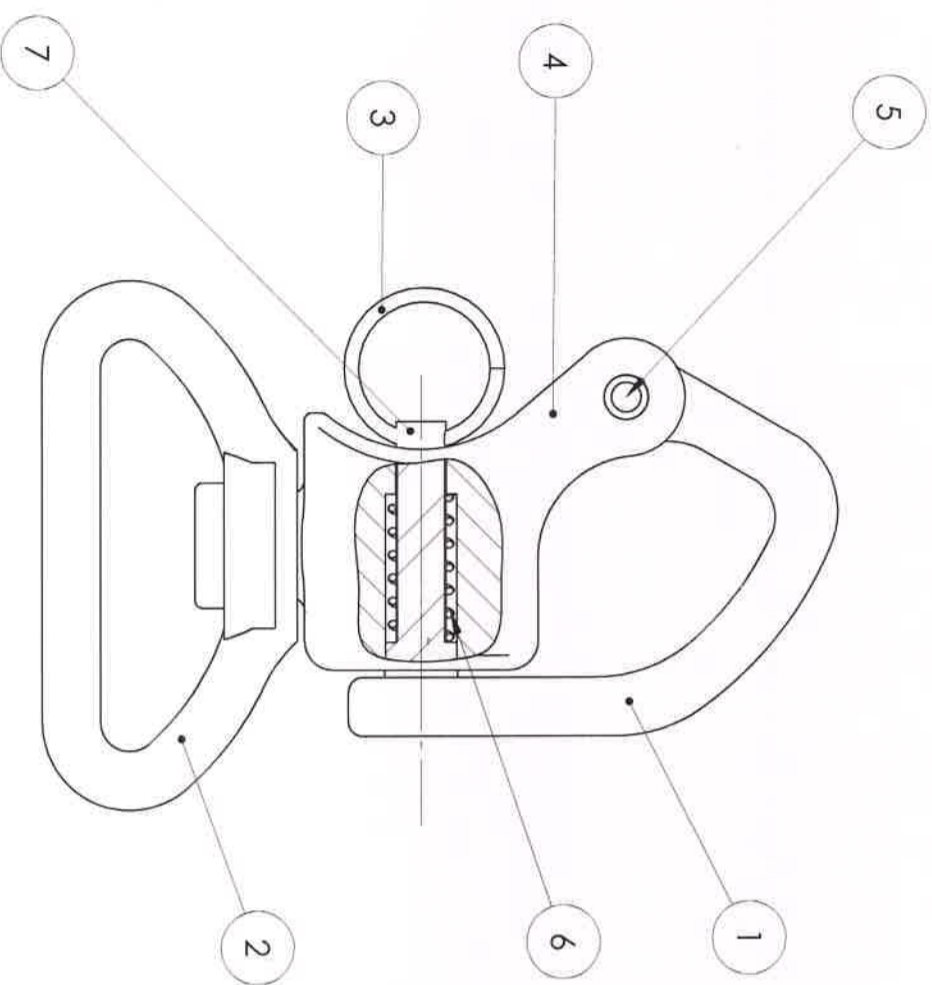

SL NO.	NOMENCLATURE	DRAWING NO.	QTY.
1	HINGE HOUSING HOOK SLING	0204 04 03 00 02 001 00AA	1
2	HOOK SLING	0204 04 03 00 02 003 00AA	1
3	RING LOCKING PLUNGER	0204 04 03 00 02 002 00AA	1
4	HOUSING HOOK SLING	0204 04 03 00 02 004 00AA	1
5	PIN HINGE HOOK SLING	0204 04 03 00 02 005 00AA	1
6	SPRING PLUNGER HOOK SLING.	0204 04 03 00 02 006 00AA	1
7	PLUNGER HOOK SLING	0204 04 03 00 02 007 00AA	1

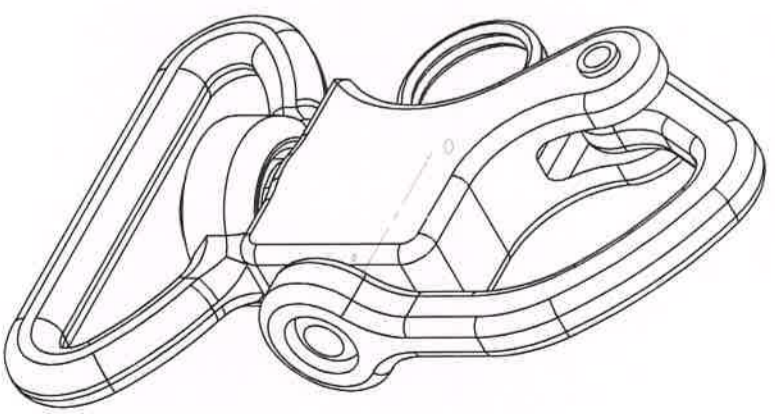

NOTE:
 ASSEMBLY IS TO BE CARRIED OUT AS PER ASSEMBLY PROCEDURE
 NO. ARDE/JVPC/3-POINT SLING/ASSEMBLY PROCEDURE/2019/04

Sr. No.	DATE	AUTHORITY	MATERIAL:	BRIEF RECORD	ZONE	CD	GO
DRN: ANKIT	14/03/2019	<i>Manish</i>	PROTECTIVE FINISH:				
SIGN: <i>Manish</i>	CHECKED						
DATE: 14/03/2019							
APPD. DATE: 14/03/2019	FOR DIRECTOR						
SEALED DATE:							
SHEET SIZE: A3	EST. MASS						
SCALE: 1:1							
DESIGN AUTHORITY							
ARDE							
PUNE 411021							
DRG No. 0 2 0 4	0 4	0 3	0 0	0 2	0 0 0	0 0 A A	
JVPC PART No. IC	SS	S	AA	A	C	SST	
DS CAT No.							
AHSP							

HOOK SLING ASSEMBLY

1	2	3	4	5	6	7	8
---	---	---	---	---	---	---	---

1 2 3 4 5 6 7 8

GENERAL TOL.: FINE / MEDIUM / COARSE
 CLASS TO IS: 2102

DRG. CONVENTIONS CONFIRM TO INDIAN STANDARDS
 DIMENSIONS ARE IN mm UNLESS OTHERWISE STATED.

TO BE STITCHED AS SHOWN WITH STEEL GREY
 (COLOUR NO 698 TO IS: 5-2007) NYLON
 THREAD TO IS: 4229
 40 STICHES PER 100 LENGTH

IS: 4727-1968-TYPE-2

ITEM NO	NOMENCLATURE	DRAWING NO	QTY.
1	SLIDING BUCKLE	0204 04 03 01 03 001 00AA	1
3	OLIVE GREEN (COLOUR NO. 220 TO IS:5-2007) NYLON WEBBING 26.0 WIDTH X 1.0 THICK X 65.0 LENGTH	IS: 4727-1968-TYPE-2	2
2	STEEL GREY (COLOUR NO. 698 TO IS: 5-2007) NYLON WEBBING 30.0 WIDTH X 2.0 THICK X 170.0 LENGTH	IS: 4727-1968-TYPE-2	1

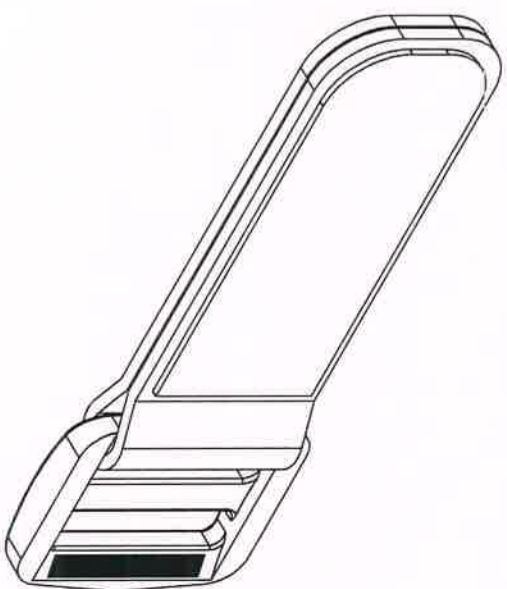
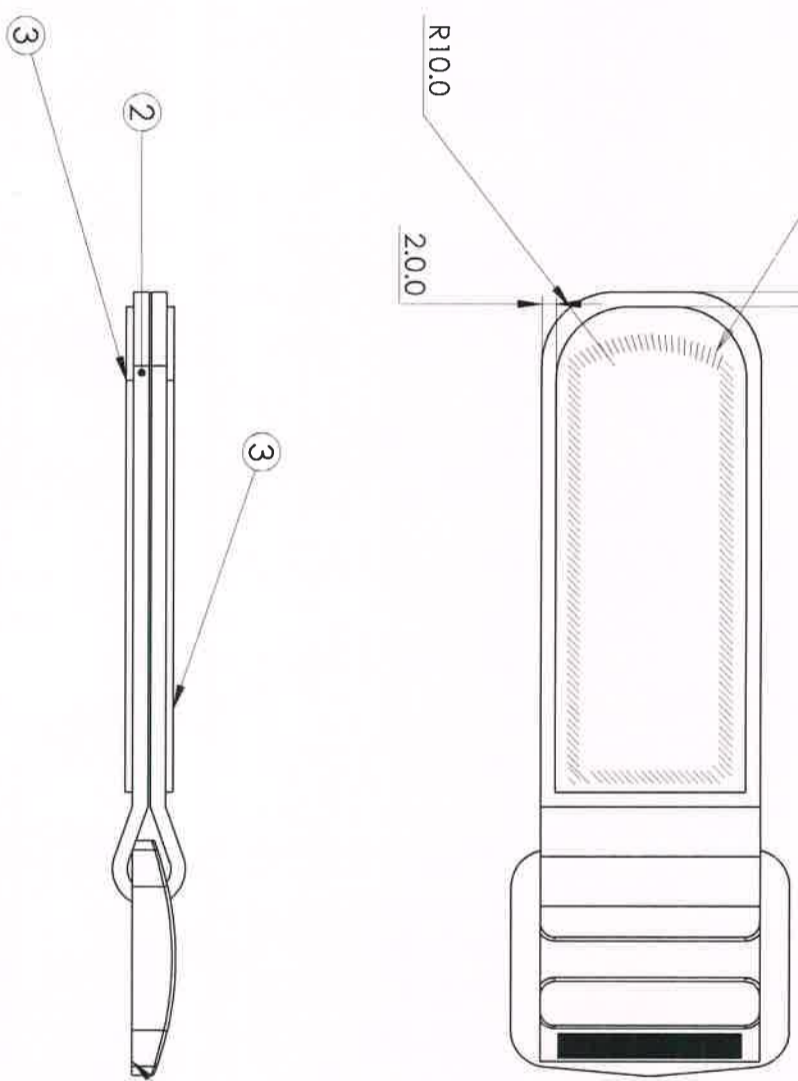

NOTE:
 ASSEMBLY IS CARRIED OUT AS PER ASSEMBLY PROCEDURE NO. ARDE/JVPC/3-POINT SLING/ASSEMBLY PROCEDURE/2019/04

Sr. No.	DATE	AUTHORITY	BRIEF RECORD	ZONE	CD	GO
DRN: ANKIT	DATE: 14/03/2019	CHECKED	MATERIAL:			
SEALING DATE:	DATE: 14/03/2019	FOR DIRECTOR	PROTECTIVE FINISH:			
SHEET SIZE: A3	SCALE: 1:1	EST. MASS	TITLE:			
DESIGN AUTHORITY	ARDE		STRAP PULLING ASSEMBLY			
PUNE 411021						

JVPC	PART No.	DS CAT No.	AHSP
0204	04	01	0000
IC	SS	S	AA
04	04	03	01
		AA	03
		A	03
		C	0000
		SST	00AA

1

2

3

4

ISS	C	A	AA	C	SS	IC	DRG No.
A A 0 0	3 0 0	2 0	0 0	3 0	4 0	4 0 2 0	0 2 0 4

GENERAL TOL. : FINE / MEDIUM / COARSE
 CLASS TO IS: 2102

DRG. CONVENTIONS CONFIRM TO INDIAN STANDARDS
 DIMENSIONS ARE IN mm UNLESS OTHERWISE STATED.

A

A

B

B

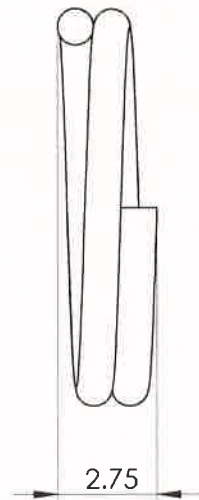

C

C

D

D

NOTE:-

- 1) WIRE DIA- 1.0
- 2) MEAN DIA- 10.0
- 3) NO. OF TURNS- 1.75
- 4) BOTH ENDS TO BE CLOSED.



Sr. No.	DATE	AUTHORITY	BRIEF RECORD	ZONE	CD	GO
					SIGN	

DRN: ANKIT
 SIGN: *[Signature]*
 DATE: 14/03/2019 CHECKED

MATERIAL:
 STEEL TO IS:4454(Pt-1), 2001,DH

APPD.
 DATE: 14/03/2019 FOR DIRECTOR

PROTECTIVE FINISH:
 PHOSPHATED TO SPECN. IS:3618-1966, CLASS 'B'

SEALED DATE:
 SHEET SIZE: A4
 SCALE: 5:1
 EST. MASS
 0.3 gm

TITLE:
RING LOCKING PLUNGER HOOK SLING

DESIGN AUTHORITY
ARDE
 PUNE 411021

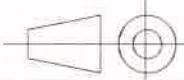

DRG No.	0 2 0 4	0 4	0 3	0 0	0 2	0 0 3	0 0 A A
	IC	SS	S	AA	A	C	SST

JVPC	PART No.	DS CAT No.	AHSP
------	----------	------------	------

F

F

1

2

3

4

