

NOTE 1:-
 TEST & MICROSCOPIC DETERMINATION
 OF NON-METALLIC INCLUSIONS FOR STEEL

- (1) MACRO ETCH AS PER ASTM E - 381
 WITH ACCEPTANCE STANDARDS C2R2S2.
- (2) NMIR TEST AS PER IS : 4163-82.

FOR EXPLANATION OF DIMENSIONING ETC.,
 SEE D.D. NO. 12, DRA. NO. 3 (LATEST ISSUE)

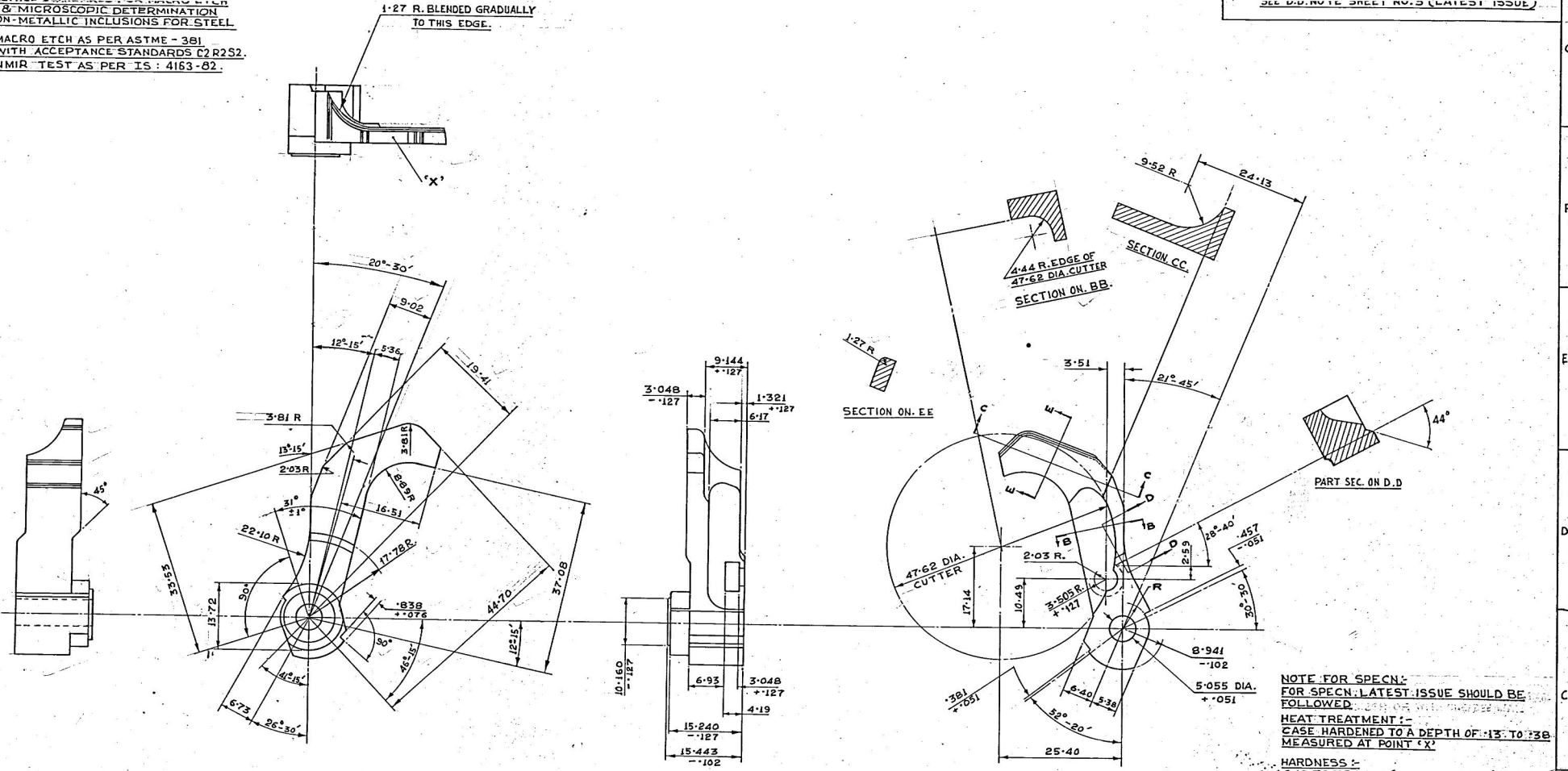

SCALE:- 2:1

NOTE FOR SPECN:
 FOR SPECN. LATEST ISSUE SHOULD BE
 FOLLOWED.

HEAT TREATMENT :-
 CASE HARDENED TO A DEPTH OF .13" TO .38"
 MEASURED AT POINT 'X'

HARDNESS :-
 640 TO 720 HV. (68.5-71.5 HRD)

PROTECTIVE FINISH :-
 PHOSPHATE TO SPECN. JSS: 0465:01-1988
 CLASS 1 OIL FINISH.

MATERIAL :-
 STEEL BS. 970 PT.1 SEC.4 Gr. 655 M13

METRIC

DATE	NAME	ASSY. DRG. 1005-001594, 1005-001595 & 1005-001596	CQA(SA) ICHAPUR
DSN.			
DRN.			
CHD.		MATL. AS STATED	
TRD.	5-12-90		
COMB.	B-12-93		
DIMENSIONS ARE IN MILLI METRES			
APPROVED.	DT. 19-6-67		
CL. NEG. RE-TRACED.			
DESIGNER'S REF.			
ARDE 657/59			
DS. CAT. No.			
1005-001631			