

DRG. NO. 33P 1310

DIMENSIONS ARE IN mm.
 UNTOLERATED DIMNS. AS PER IS : 2102 (MED)
 SHARP CORNERS SHOULD BE BLUNT O R 0.5
 PROTECTIVE FINISH ON ASSEMBLY.

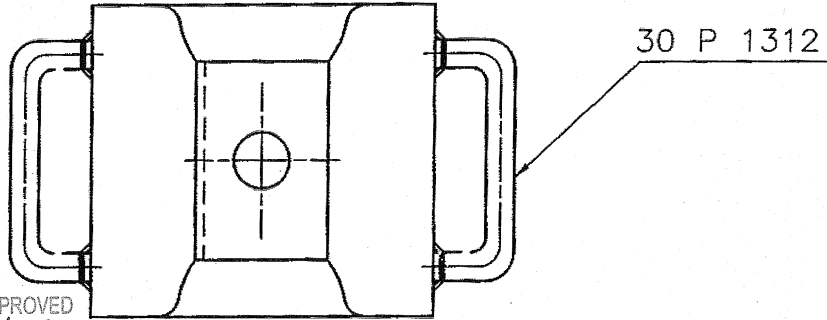

UN CONTROLLED COPY
 CERTIFIED CORRECT COPY OF APPROVED
 DRAWINGS AT THIS DATE 11/3/22
S. Venkatesh
 DESIGN & DRAWING OFFICE,
 ORDNANCE FACTORY, TIRUCHIRAPPALI - 620 016.

30P 1311

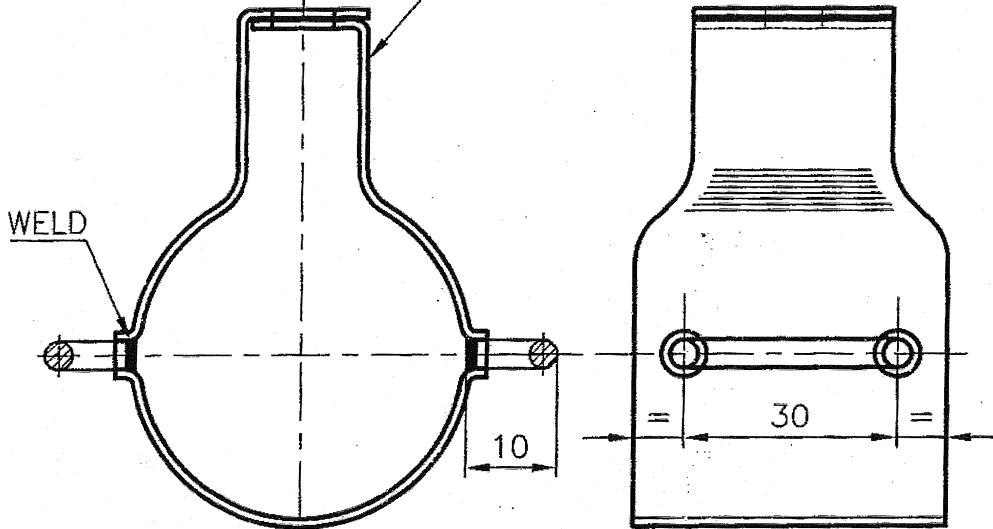

MATERIAL: IS:2507 -1975, GRADE-1, DESIGNATION-45C8.
 (OR) BS 1449, PART-1, 1983, GRADE - CS50
 HARDNESS: 30 - 35 HRC

PART NO.	DESCRIPTIONS	NO OFF	MATERIAL	TREATMENT	REMARKS
	SIGNATURE & DATE				SCALE 1:1
	TRACED				STORE DRG. NO. ---
	DRAWN <i>S. Venkatesh</i>				OPERATION NO. ---
	CHECKED <i>[Signature]</i>				SHEETS: 1
	HOS/D&DO <i>[Signature]</i>				SHEET No.: 1
	NODAL OFFICER FOR MGL <i>[Signature]</i>				
	OFFICER/D&DO				
	APPROVED ON. 25/02/2015				
		SUB: CLAMP HANDLE SUB -ASSY			
		FOR: FRONT GRIP ASSY.			
		OF: 40mm. MGL			
		DES. REF. NO.			
		DRG. No.: 30P 1310			
		 ORDNANCE FACTORY TIRUCHIRAPPALI-16.			

AMENDMENTS SIG. & DATE

DRG.NO. 30P 1311

DIMENSIONS ARE IN mm.
UNTOLERATED DIMNS. AS PER IS : 2102 (MED)
SHARP CORNERS SHOULD BE BLUNT O R 0.5
PROTECTIVE FINISH ON ASSEMBLY.

UN CONTROLLED COPY
 CERTIFIED CORRECT COPY OF APPROVED
 DRAWINGS AT THIS DATE, 15/3/22
S. Venkatesh 15/3/22
 DESIGN & DRAWING OFFICE,
 ORDNANCE FACTORY, TIRUCHIRAPPALI - 620 016.

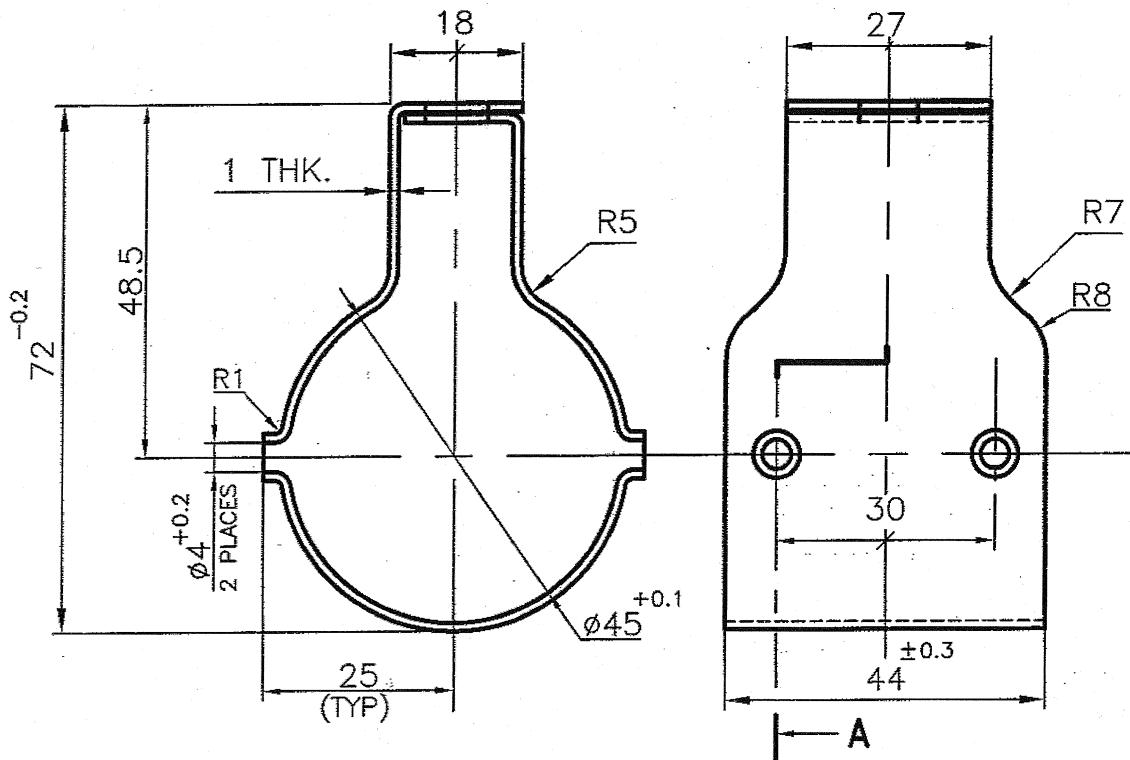
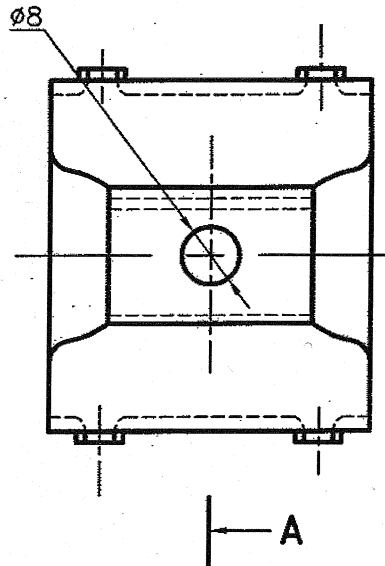

MATERIAL: IS:2507 -1975, GRADE-1, DESIGNATION-45C8.
(OR) BS 1449, PART-1, 1983, GRADE - CS50
HARDNESS: 30 - 35 HRC

PART NO.	DESCRIPTIONS	NO OFF	MATERIAL	TREATMENT	REMARKS
⊕	SIGNATURE & DATE.	SUB: CLAMP HANDLE			SCALE 1:1
TRACED	<i>S. Venkatesh</i>	FOR: CLAMP HANDLE SUB ASSY			STORE DRG.NO.
DRAWN		OF: 40mm. MGL			---
CHECKED		DES.REF.NO.			OPERATION NO.
HOS/D&DO	<i>[Signature]</i>	DRG. No.: 30P 1311			---
NODAL OFFICER/ FOR MGL.	<i>[Signature]</i>	ORDNANCE FACTORY TIRUCHIRAPPALI-16.			SHEETS: 1
OFFICER/ D&DO					SHEET No.: 1
AMENDMENTS	SIG. & DATE	APPROVED ON. 25/02/2015			

DRG. NO. 30P 1312

DIMENSIONS ARE IN mm.
 UNTOLERATED DIMNS. AS PER IS : 2102 (MED)
 SHARP CORNERS SHOULD BE BLUNT O R 0.5
 PROTECTIVE FINISH ON ASSEMBLY.

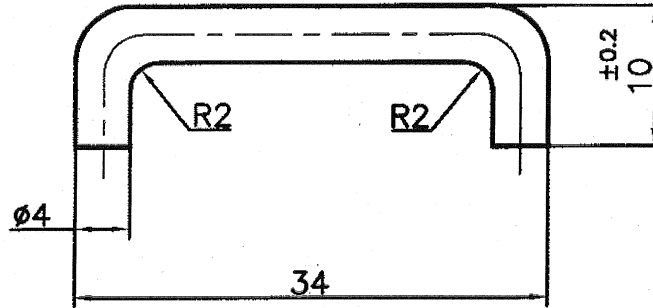

UN CONTROLLED COPY
 CERTIFIED CORRECT COPY OF APPROVED
 DRAWINGS AT THIS DATE 13/3/22
 DESIGN & DRAWING OFFICE,
 ORDNANCE FACTORY, TIRUCHIRAPPALI - 620 016.

QTY. REQUIRED PER GUN - 2 NOS.

MATERIAL : IS:1875 - 1992, CLASS-2, DESIGNATION-20C8.

ALTERNATE MATERIAL : En3A (OR) En8

HARDNESS: 24 - 32 HRC

PART NO.	DESCRIPTIONS	NO OFF	MATERIAL	TREATMENT	REMARKS
	SIGNATURE & DATE.	SUB: <u>BRACKET SLING</u>			SCALE 1:1
	TRACED	FOR: <u>CLAMP HANDLE SUB ASSY</u>			STORE DRG.NO. ---
	DRAWN <i>S. Venkatesh</i>	OF: <u>40mm. MGL</u>			OPERATION NO. ---
	CHECKED	DES. REF. NO.			SHEETS: 1
	HOS/D&DO <i>[Signature]</i>	DRG. No.: <u>30P 1312</u>			SHEET No.: 1
	NODAL OFFICER/ FOR MGL OFFICER/ D&DO <i>[Signature]</i>	ORDNANCE FACTORY TIRUCHIRAPPALI-16.			
AMENDMENTS	SIG. & DATE	APPROVED ON. 25/02/2015			