

NOTES:

1. FINISH $\sqrt{3.2}$ EXCEPT AS NOTED.
2. BREAK EDGES 0.076 +0.305 UNLESS OTHERWISE SPECIFIED.
3. MATERIAL: STEEL, CARBON ASTM A109.
4. FINAL PROTECTIVE FINISH: FINISH 5.312 OR 5.3.2.2 OF MIL-STD-171.
5. ASME Y14.5M-1994 APPLIES.
6. GAGE DIMENSION OF -A- IS 25.527 BASIC.

REVISIONS				
ZONE	REV.	DESCRIPTION	DATE	APPROVED
	A	CREATE DRAWING	8/11/2015	G. HERSHBERGER

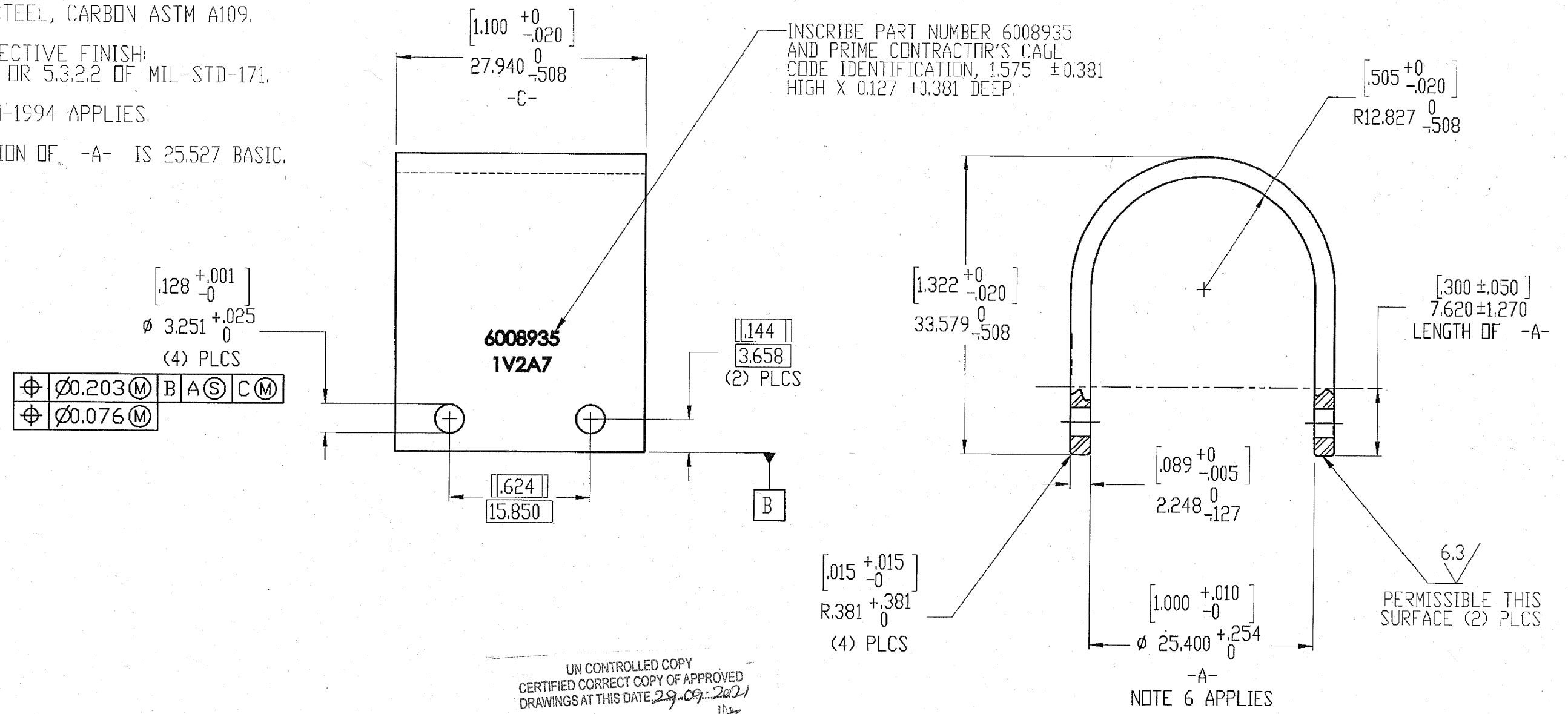

UN CONTROLLED COPY
 CERTIFIED CORRECT COPY OF APPROVED
 DRAWINGS AT THIS DATE. 29.09.2021
 DESIGN & DRAWING OFFICE,
 ORDNANCE FACTORY, TIRUCHIRAPPALI - 620 016.

Provisionally Approved
 24 AUG 2021
 For (mcd) (API)

ITAR CONTROLLED THIS DOCUMENT IS CONTROLLED UNDER THE ITAR. IT MAY NOT BE PROVIDED TO A NON-U.S. RESIDENT WITHOUT THE WRITTEN APPROVAL OF THE U.S. GOVT. VIOLATIONS WILL RESULT IN CIVIL OR CRIMINAL PENALTIES. PROPRIETARY AND CONFIDENTIAL THE INFORMATION CONTAINED IN THIS DRAWING IS THE SOLE PROPERTY OF OHIO ORDNANCE WORKS, INC. ANY REPRODUCTION IN PART OR AS A WHOLE WITHOUT THE WRITTEN PERMISSION OF OHIO ORDNANCE WORKS, INC. IS PROHIBITED.	UNLESS OTHERWISE SPECIFIED: DIMENSIONS ARE IN MM/(INCHES) ALL THREAD DIM. ARE IN INCHES TOLERANCES: FRACTIONAL ANGULAR: MACH ± BEND TWO PLACE DECIMAL ±0.25 THREE PLACE DECIMAL ±0.127	NAME: PMD DATE: 08/10/15	OHIO ORDNANCE WORKS, INC. COVER, FRONT SIGHT, 00W50BMG SIZE: B 6008935 REV: A SCALE: 2:1 WEIGHT: SHEET 1 OF 1
	INTERPRET GEOMETRIC TOLERANCING PER:	DRAWN	
	MATERIAL:	CHECKED	
	FINISH:	ENG APPR.	
DO NOT SCALE DRAWING		MFG APPR.	
		G.A.	
		COMMENTS:	