

SIDE SHOCK ABSORBER

3

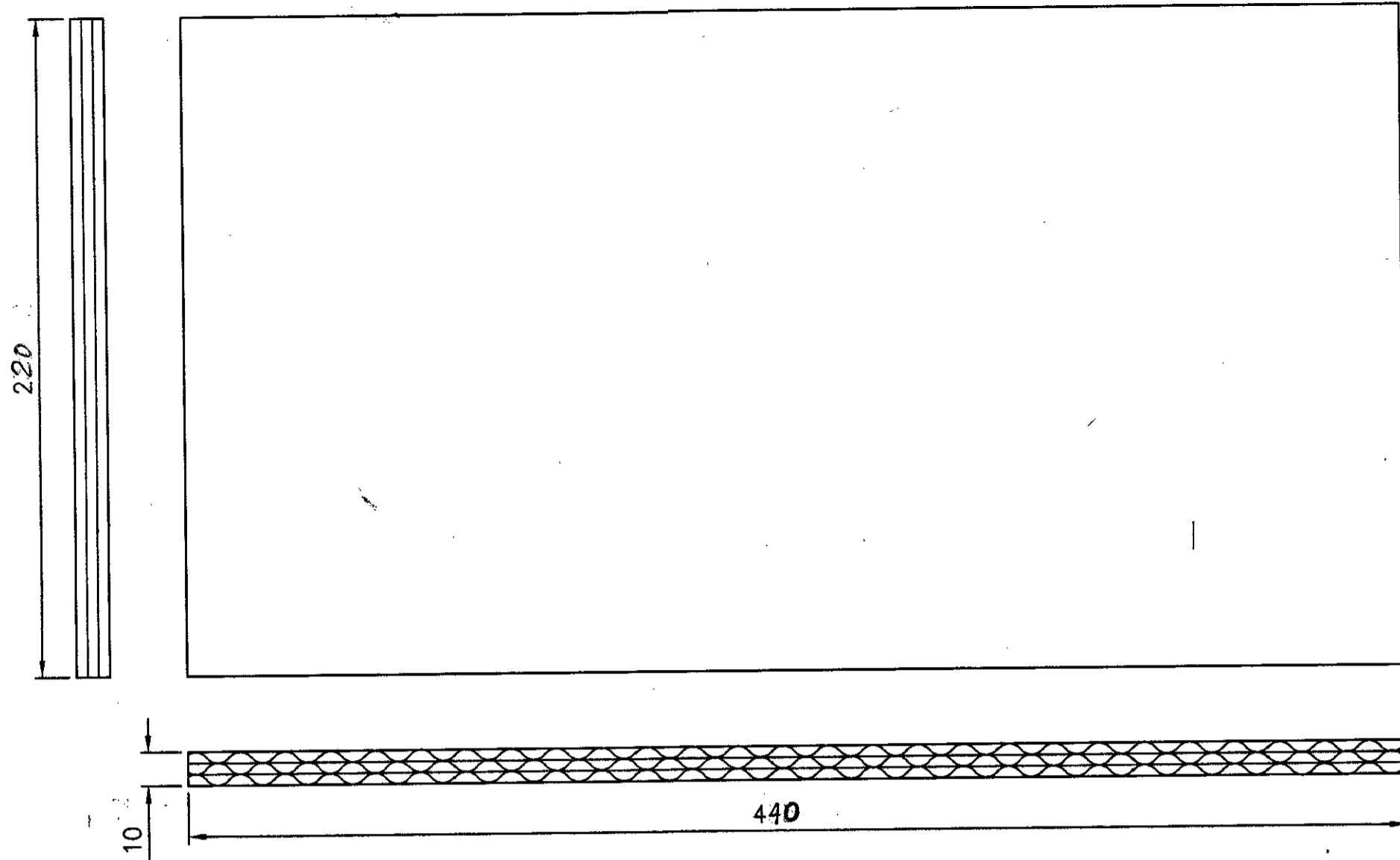

COMPONENT GUIDE

4

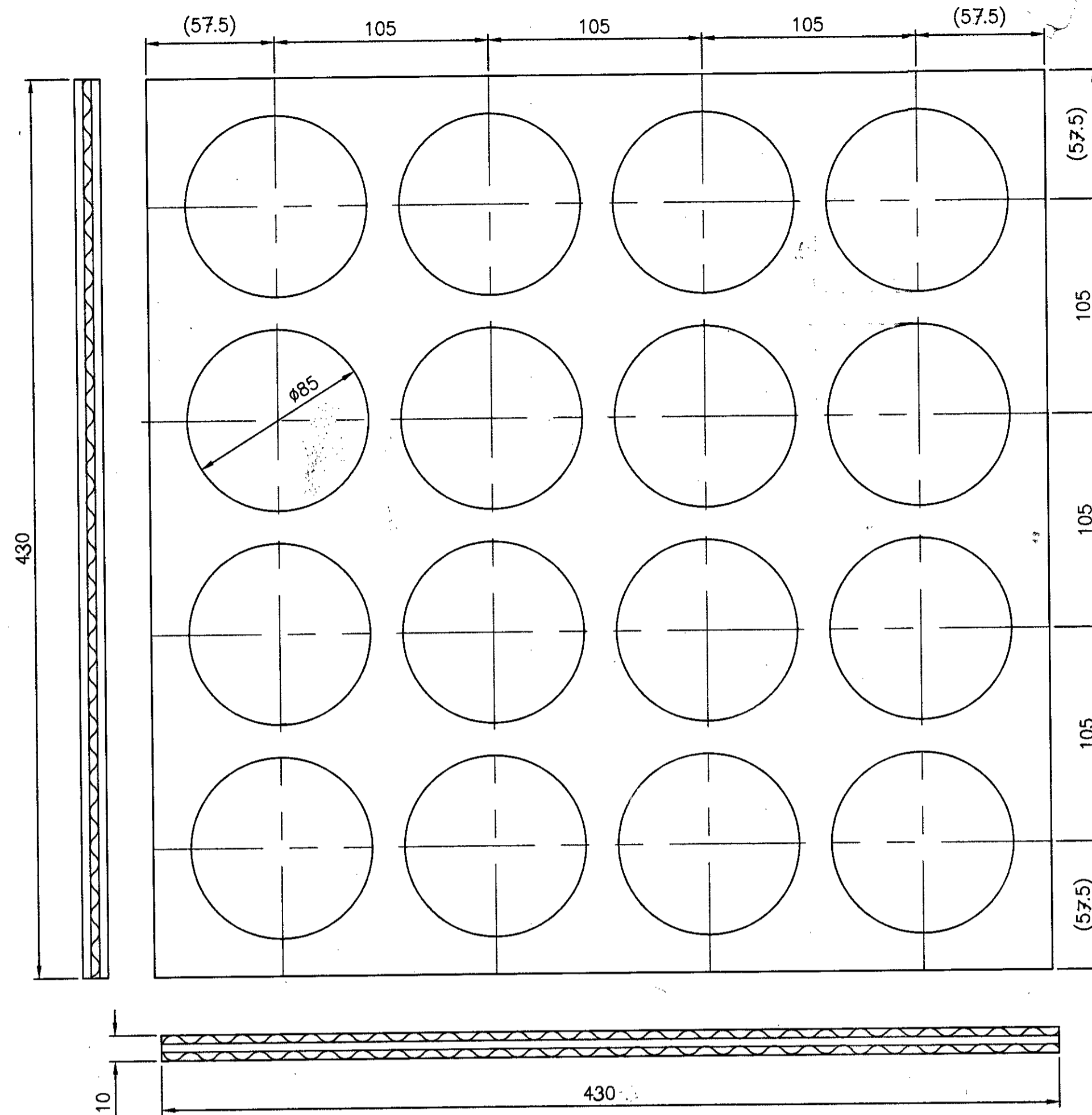

SHOCK ABSORBER (TOP & BOTTOM)

2

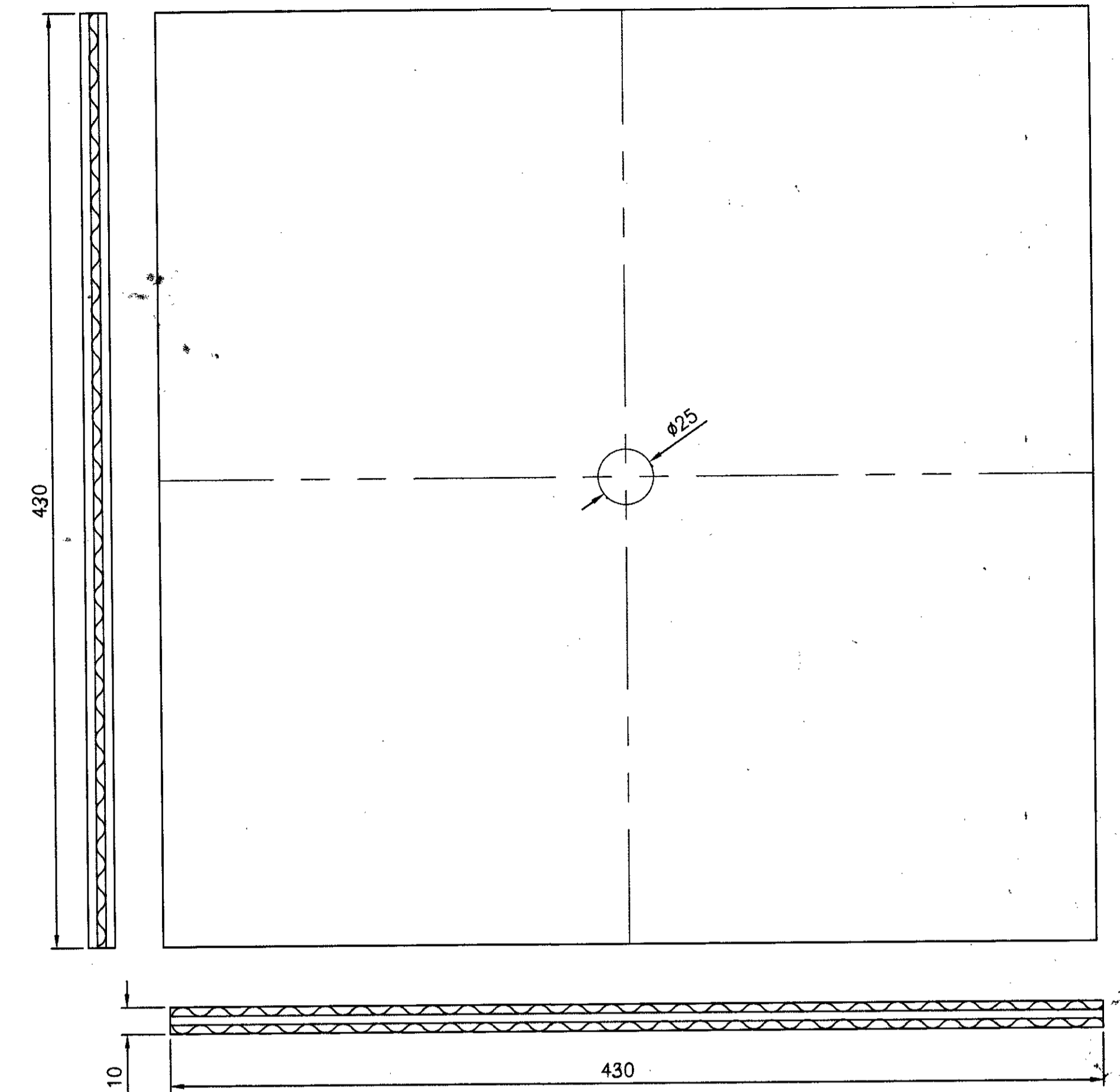

PARTITION

5

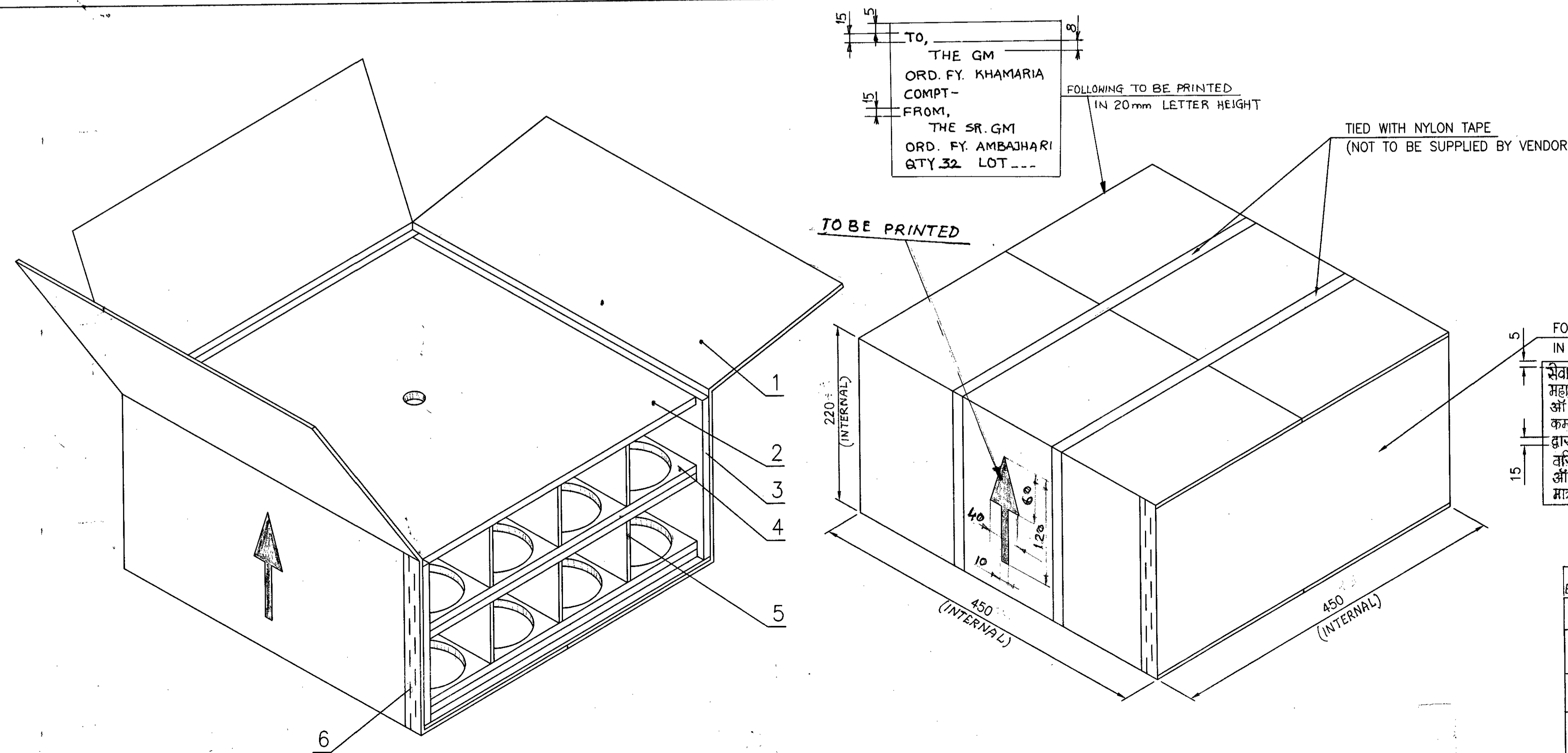
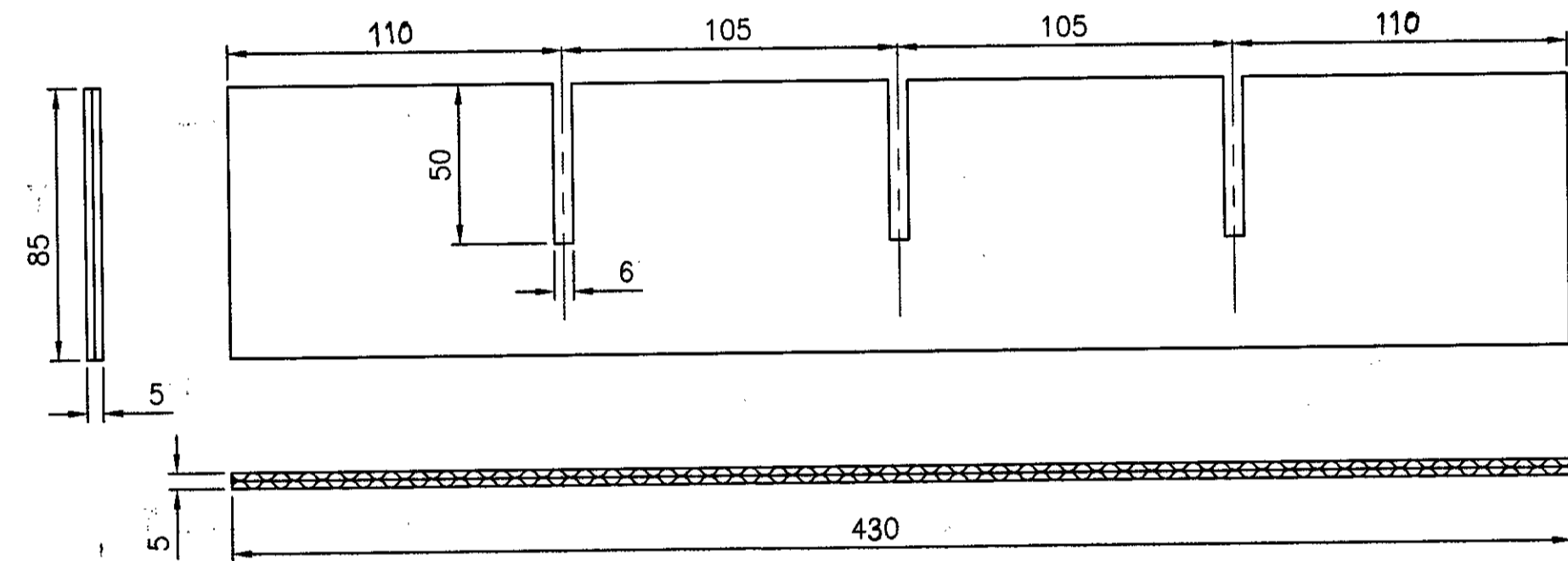

TO, THE GM
ORD. FY. KHAMARIA
COMPT-
FROM, THE SR. GM
ORD. FY. AMBAJHARI
QTY 32 LOT ---

FOLLOWING TO BE PRINTED
IN 20mm LETTER HEIGHT

FOLLOWING TO BE PRINTED
IN 20mm LETTER HEIGHT

सेवा में
महाप्रबंधक
ऑ. फ. खमरिया
कम्प्लेंट
द्वारा
वरिष्ठ महाप्रबंधक
ऑ. फ. अम्बाजरी
मात्रा 32. लॉट

- NOTE :
- PART NO. 1 & 5 : 150 GSM KRAFT PAPER, 5-PLY, DOUBLE WALL, VERTICAL NARROW FLUTING, 5mm THICK.
 - PART NO. 2 & 4 : 120 GSM KRAFT PAPER, 9-PLY, FOUR WALL, NARROW FLUTING, 10mm THICK & CROSS FLUTED in ALTERNATE FLUTES SHOULD RUN ACROSS EACH OTHER
 - PART NO. 3 : 120 GSM KRAFT PAPER, 9-PLY, 4 WALL, VERTICAL NARROW FLUTING, 10mm THICK.
 - PARTS TO BE MARKED WITH THE MANUFACTURER'S NAME/INITIAL OR TRADE MARK.
 - GENERAL WORKMANSHIP AND FINISH SHALL BE GOOD THROUGH OUT.
 - ALL PARAMETERS ARE GOVERNED BY THE SPECN. IS : 2771(PLI) LATEST ISSUE. & SUBJECTED TO PROPER FITMENT OF ALL THE PARTS

REV.	DATE	DESCRIPTION	SIGN.
88	04.06.15	In Nomenclature Packing Carton was	
E 2376		Packing Box, Drg. adv. To 'E'	
191	18.07.09	DESIGN UPDATED.	
D 2009		D.A. NO. 191/2009.	
14/04/04	17.05.04	Printing matter in Eng. Added DRG	
334/05	8.10.03	Printed matter in Hindi cons in	
B		English. DRG. Adv. To 'B'	
297/002	31.7.02	DRG. Adv. No. 13 D.M. 430 & 220	
A		DATE 4.95 & 225. Rev. Adv. 24	
		6.00 2.00	
REV.	DATE	NOMENCLATURE	SIGN.

PART	DESCRIPTION	NO. OFF	BURSTING STRENGTH	REMARKS
6	STAPLES, MS GALVANISED 12 x 3 x 0.8 THICK	AS REQD.		
5	PARTITION	12		
4	COMPONENT GUIDE	2		
3	SIDE SHOCK ABSORBER	4		
2	SHOCK ABSORBER (TOP & BOTTOM)	3		
1	BOX	1	MINIMUM 9kg/cm ²	

DIMENSIONS ARE IN mm		MATERIAL: AS ABOVE		ORDNANCE FACTORY AMBAJHARI	
THIRD ANGLE PROJECTION		NOMENCLATURE:		DRG. NO:	
SCALE: 1:2 (1:4)		CORRUGATED FIBREBOARD PACKING CARTON		FS-2376E'	
2002	NAME	DATE	SHEET NO: 1		
DRAMP	21/01/02	21/01/02	NO. OF SHEETS: 1		
TRP	21/01/02	21/01/02	OPERATION NO:		
C	21/01/02	21/01/02	M/C:		
JH	21/01/02	21/01/02	STORE: 84mm CG		
T	21/01/02	21/01/02	COMPT: 0 SHELL BODY (F1321-309540)		
APPRO:			23 STABILIZING TUBE (F1301-026222)		

BOX IN CLOSED CONDITION.