

MATERIAL : AISI / SAE 4340, MIM 4340 OR EQUIVALENT
 HARDNESS : 63-66 HR 15N
 SUPPLY CONDITION : Mn PHOSPHATE

NOTE:-
 GENERAL TOLERANCES ARE
 1. WHOLE NUMBER = ±0.76 mm
 2. ONE DECIMAL = ±0.25 mm
 3. TWO DECIMAL = ±0.13mm
 4. ANGULAR DIMENSIONS = ±1°

HOS | MPM
 जाणित प्रति, CERTIFIED COPY OF
 ड्राइंग / ड्राइंग / गज सिस्तेम
 Dwg/LAYOUT/GAUGE SCHEDULE
 दिनांक / AT THIS DATE..15..06..2017
 श्री सी / CDD
 गणेश कर्वारी, इंग्लिश
 RIFLE FACTORY, ISHAPORE

PIN ARM
 (THROUGH MM ROUTE)

DRG. REF. NO. - D.S.CAT 1005-003203
 DRG. NO. - RFL.SK 10124

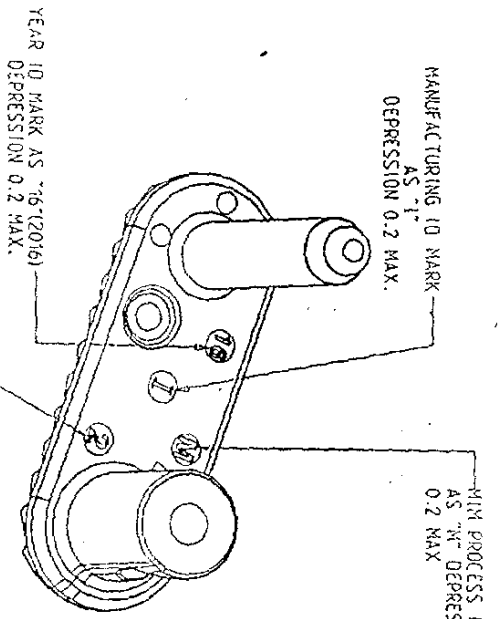
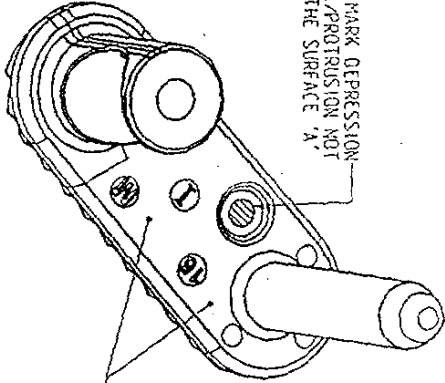
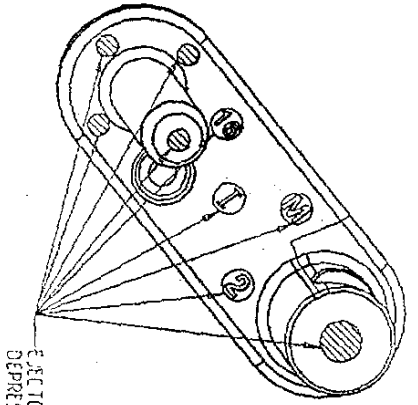
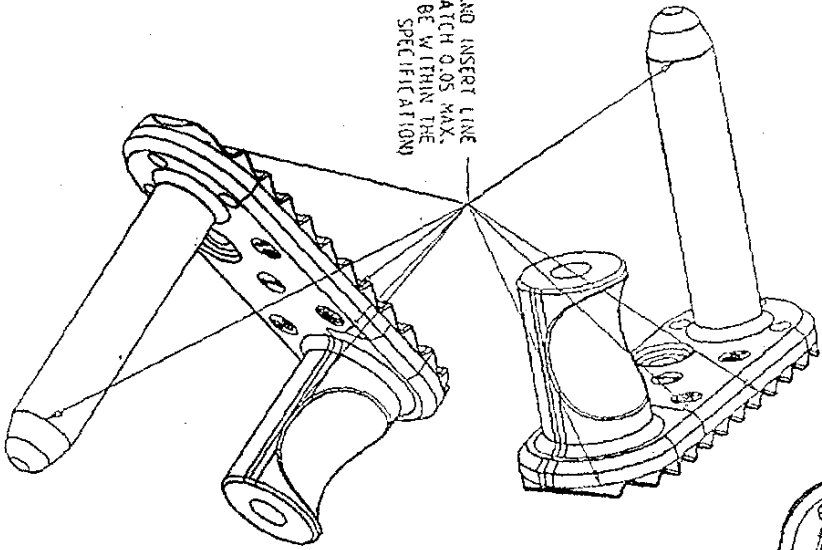
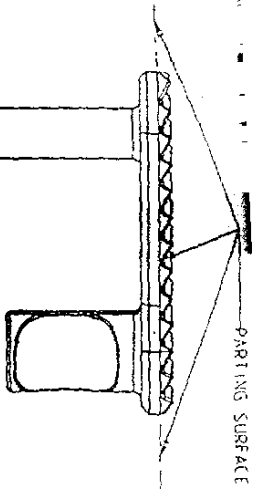

NOTES:-
 VOLUME OF THE PART = 0.305 CC
 MINIMUM WALL THICKNESS = 1.09 mm

PIN ARM
 (THROUGH MM ROUTE)
 DRG. REF. NO. - D.S.CAT 1005-003203
 DRG. NO. - RFLSK 10124

