

4

3

2

1

SS

IC

S

AA

A

C

SS

SST

DRG.No. **9102 03 04 11 05 00DA**

GEN. TOL. MEDIUM/COARSE/FINE CLASS TO IS:2102

DRAWING CONVENTION CONFORM TO INDIAN STD. DIMNS IN mm UNLESS OTHERWISE STATED.

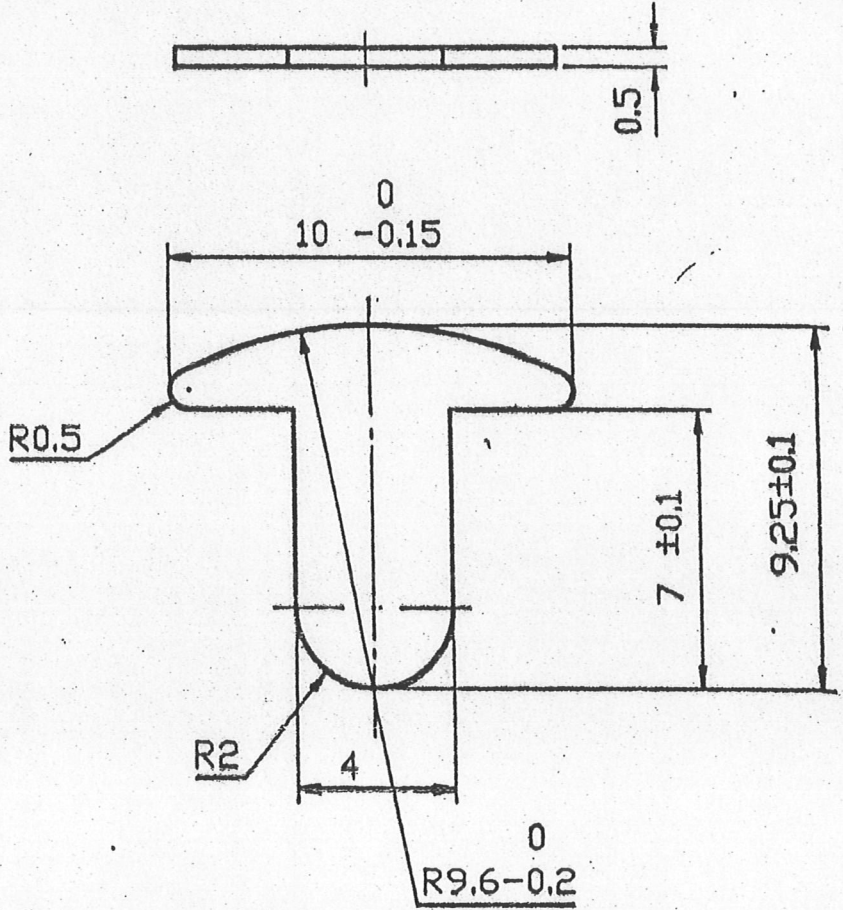

**NOTES:**

- 1) DIMNS. APPLY AFTER PLATING
- 2) HARDNESS 450±25 VPN /10 Kg.
- 3) BURRS/SHARP EDGES NOT PERMITTED.

R No.	DATE	AUTHORITY	BRIEF RECORD					ZONE	CD	GO									
DRN. SABLE		CHD. <i>[Signature]</i>	MATERIAL: STEEL TO SPEC. BS 970 En 42 G																
APPD. DATE: 15/6/98	FOR DIRECTOR		PROTECTIVE FINISH: TO BE NICKEL PLATED TO SERVICE Gd.No.3 TO SPEC. IS:1068-1985. OR ELECTROLESS NICKEL PLATING WITH BOND STRENGTH MIN.2800 Kg/Cm <sup>2</sup>																
SEALED DATE:			SCALE: 5:1	EST.MASS: 0.18 g	TITLE: STRIP STRIKER														
DESIGN AUTHORITY ARDE																			
DRG.No.	9102 03 04 11 05 00DA																		
PART No.	DS CAT No.					AHSP													