

1 2 3 4 5 6 7 8

A
B
C
D
E
F

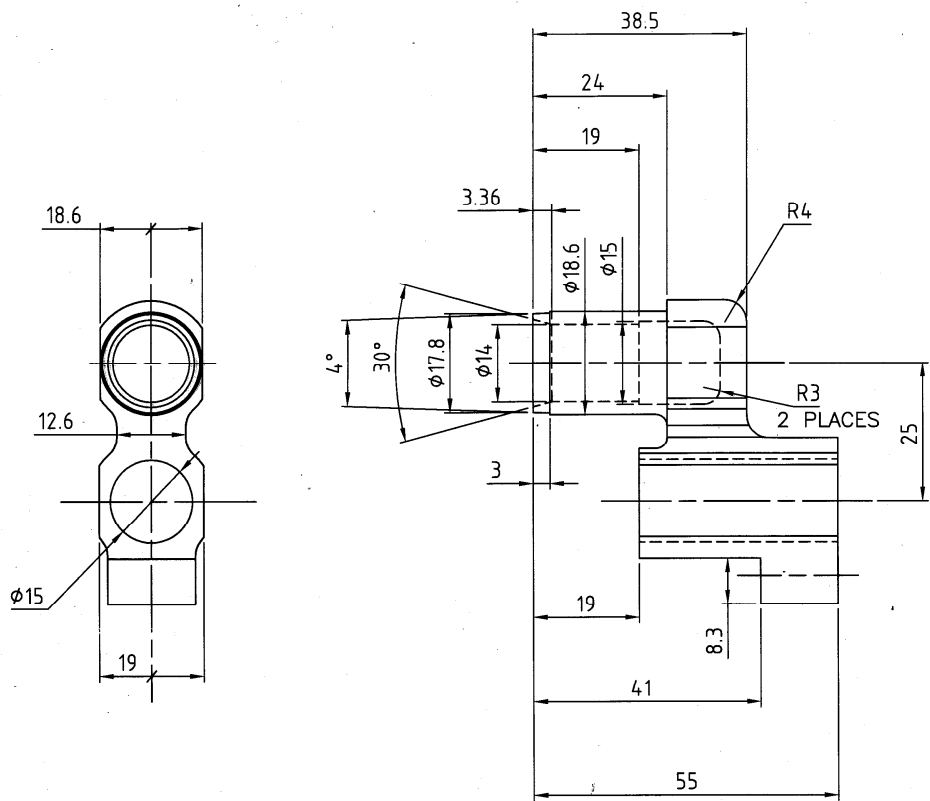

MATERIAL: BS: 970 PT1: 1983, 817 M40.
ALT.MATL: BS: 970 PT1: 1983, 826 M31.
HARDNESS: 300-350 HV.

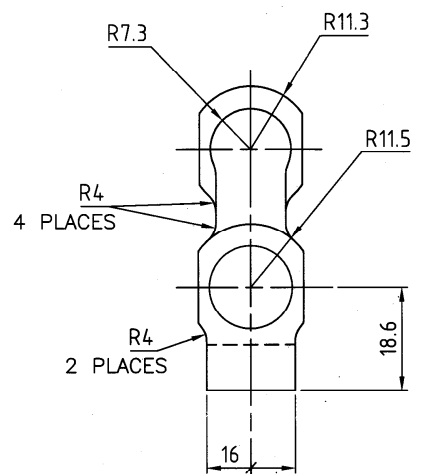

DIMENSIONS ARE IN mm.
UNTOLERATED DIMNS. AS PER IS : 2102 (MED)
MARK DRAWING No.

G. K. S.
DGM/PROJECT

1	PRE MACHINED BLANK STAGE-2	1	AS ABOVE		
PART NO.	DESCRIPTIONS	NO OFF	MATERIAL	TREATMENT	REMARKS
	SIGNATURE & DATE.				SCALE ---
TRACED					STORE DRG.NO. K-1205
DRAWN					OPERATION NO. ---
CHECKED					
HOS/D&DO					
OFFICER/PRODN.					
OFFICER/D&DO					
AMENDMENTS	SIG. & DATE	APPROVED ON. 08.07.2016	ORDNANCE FACTORY TIRUCHIRAPPALLI-16.		SHEETS: 1 SHEET No.: 1

1 2 3 4 5 6 7 8