



This drawing is strictly private and confidential. It is the exclusive property of ASHOK LEYLAND Ltd., and must not be used, copied or reproduced in part or whole without the company's written permission.

**ASHOK LEYLAND LTD.**  
TECHNICAL CENTRE, VELLIVoyalCHAVADI

**VFJ**

ALTERATIONS	ER-DIN DATE	GRADE	SUFFIX

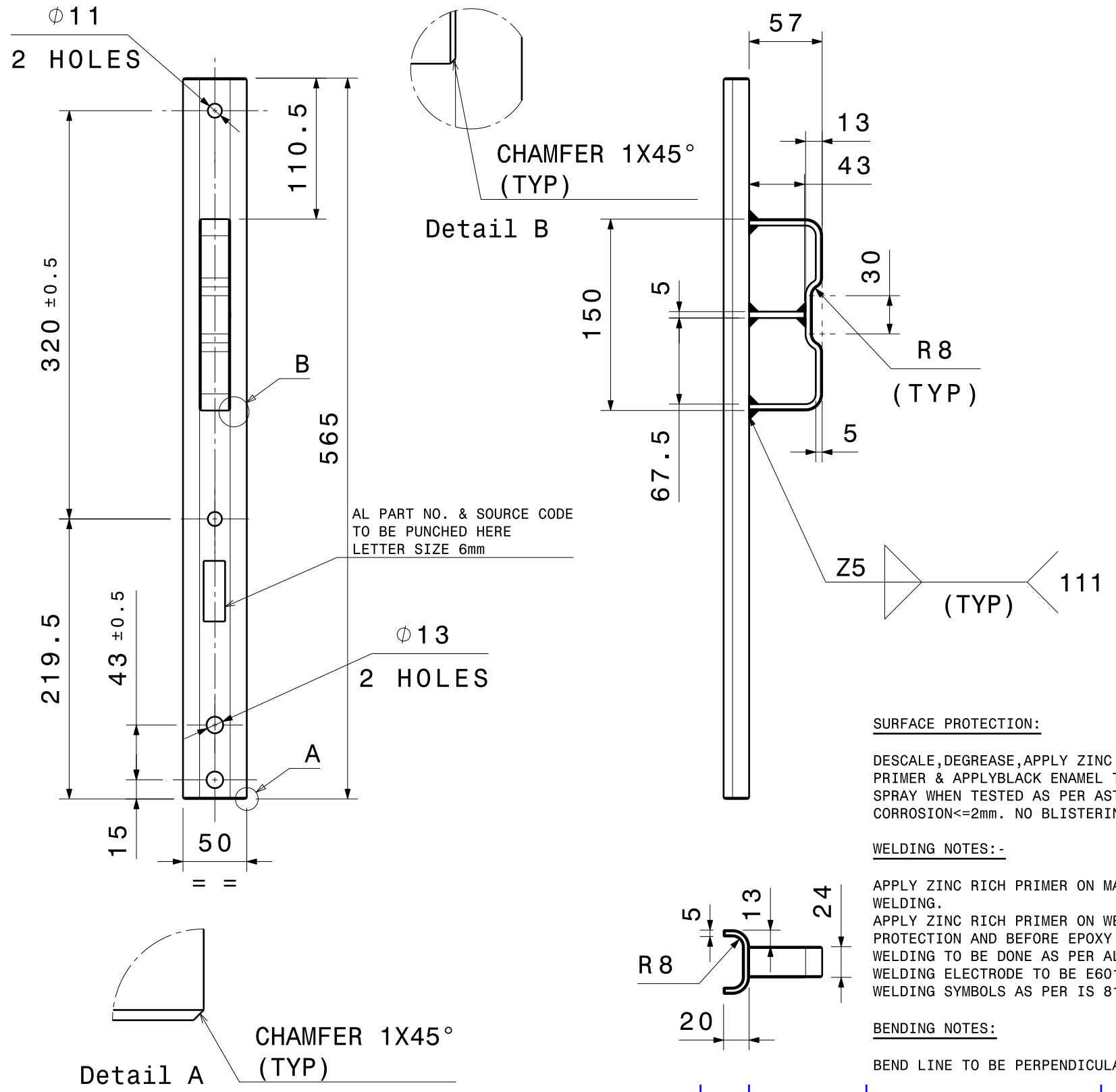

Q - CRITICAL S - SAFETY I - IMPORTANT. THIS DRAWING CONTAINS SAFETY CHARACTERISTICS

SL No	PART NO:	DESCRIPTION	SIZE	MATERIAL	QTY
<b>BILL OF MATERIALS</b>					

TOLERANCES		REFER IS:2102 ; MEDIUM FOR MACHINING AND COARSE FOR FABRICATION
SURFACE PROTECTION	FABRICATED COMPONENTS TO BE DEGREASED, DESCALED. APPLY ZINC PHOSPHATE, APPLY EPOXY PRIMER AND APPLY BLACK ENAMEL TO MEET 300 HRS OF SALT SPRAY LIFE WHEN TESTED AS PER ASTM B117 (UNDER PELLICULAR CORROSION <= 2mm. NO BLISTERING IS ALLOWED.) MACHINED SURFACE TO BE APPLIED WITH RUST PREVENTIVE OIL TO IS:1154	SURFACE FINISH AS PER IS:3073(CLA VALUE)
METRIC THREADS	METRIC SCREW THREADS SHALL CONFORM TO THE LIMITS AND TOLERANCES SPECIFIED IN THE CURRENT IS:4218 CLASS 6g EXTERNAL OR 5H INTERNAL	SHARP EDGES TO BE REMOVED DIMENSIONS ARE IN MM DO NOT SCALE DRAWING

APPEARANCE ITEM	ER-DIN	DATE
YES	NO	---
FINISHED WEIGHT (APPROX):	2.0 Kg	REF PT NO: ---
SUPERSEDES:	---	S/A PT NO: ---
SCALE	N.T.S	SPEC NO: ---

AL PLM VAULT  
 REVISION:#.0 | DATE:31-07-2009 | STATUS:APPROVED  
 STAGE:II | ER-DIN NO/DATE: ER-DIN-0003479 / 14-08-2009  
 ALTERED BY:jagtaptushar.ades | CHECKED:samson.alvvc  
 MED APPROVAL:ganeshpm.alvvc | APPROVED:samson.alvvc  
 DIGITALLY SIGNED. PHYSICAL SIGNATURE NOT REQUIRED

DRAWN/ DATE	CHECKED/ DATE	MED APPROVAL /DATE	APPROVED/ DATE	STDS APP/ DATE
MPK 13.07.09	SDC 16.07.09	XXXX XX.XX.XXXX	KSH 16.07.09	---

**MATERIAL** PLATE 5 THK - IS 2062 Gr.A

**HEAT TREATMENT** ---

**REMARKS**  
FOR STALLION MKIV 180 HP RHD

**DESCRIPTION**  
**SILENCER MTG. BRACKET**

**PART NO.** **F 3 B 0 0 7 1 4 #.0**

SHEET NO: .....1..... OF... 1..... **A3**