

DRAWING NUMBER  
432.40.103

SHEET No. 1 OF 1

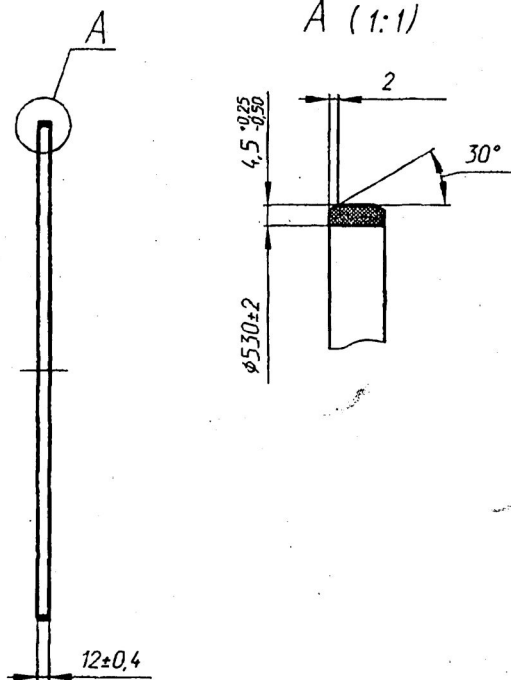

- 1) Alternate material is rubber ИРП-1078 or 51-3029 TY 005216-99.
- 2) Rounding off of corners / angles with radius 0<sup>+1</sup> mm is allowed.
- 3) Other requirements are as per TY 005216-99, code 253110 and 520.TY1.
- 4) Mark on tag.

DRG. INDIANISED BASED ON RUSSIAN ORIGINAL ISSUE -12  
COMMON TO T-72 & BLT

(12A) ALT. MATL: RUBBER GRADE N2 TO SPECN. CQA(HV)/NBR  
\* 175.40Cb-5Cb, 175.40Cb-6Cb

DRN	<i>J. Deaul</i>	MATERIAL:	RUBBER 9831 TY 005216-99	USED ON:- IN-BULK ** 172.40.cb-1Cb 172.40.cb-2Cb
CHD	<i>Chandrayy</i>	CONTROLLERATE OF QUALITY ASSURANCE (HEAVY VEHICLES) AVADI		
APPD	<i>Chanchal</i>	TITLE:- PACKING RING		
DATE	18-02-04	D S CAT NUMBER		
SCALE:- 1 : 5		DRAWING NUMBER 432.40.103		
DIMENSIONS IN mm		ALL SHARP EDGES AND CORNERS TO BE REMOVED UNLESS OTHERWISE STATED MACHINED CORNERS TO HAVE R OUT-SIDE R INSIDE EQUIVALENT CHAMFERS ARE PERMISSIBLE.		
TOLERANCE ON DIMNS UNLESS OTHERWISE STATED IS : 2102-69		12A 13.01.07 Lt.No.81312/CQA(HV)/DB-III/Ait. Matl. dt.12.10.06.		
ALL THREADS TO CONFORM TO		ISSUE DATE NATURE OF AMENDMENTS		

PILOT SAMPLE SHOULD BE APPROVED BY A H S P BEFORE BULK PRODUCTION.

EST. WT. (Kg) 0.08 TO BE STAMPED OR MARKED WHERE INDICATED THUS # ( LETTERS)

356  
SUPPLY CODE  
U-01-1-1  
D90013

F-13  
34

SIZE A3

8

7

6

ISSUE

DATE

NATURE OF AMENDMENTS

