

DRG. NO. K-6013

NOTE: REMOVE ALL SHARP EDGES & BURRS  
TWO PIECES PER RIFLE

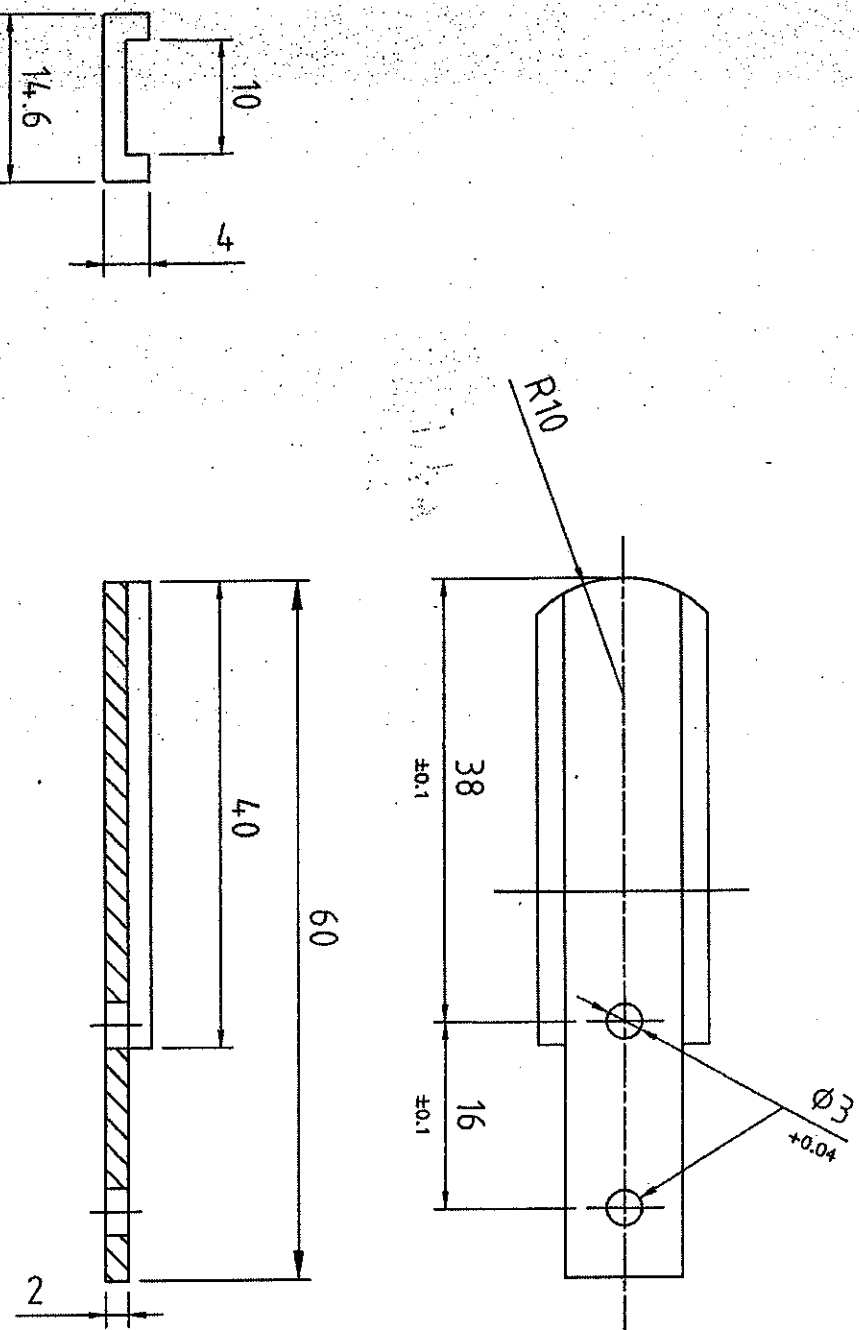

K-6013

MATERIAL: BS 970 PT.1 SEC. 2 GR. 080 M40 (En-8)  
HARDNESS : 280-330 VPN  
PROTECTIVE FINISH : PHOSPHATED TO SPECN WPN/GEN/3 CLASS II, OIL FINISH.

G.Ka DGM NODAL OFFICER (TAR)		PART NO. DESCRIPTIONS		NO. OFF		MATERIAL		TREATMENT		REMARKS	
SIGNATURE & DATE		SUB: PLATE SLEEVE LEFT & RIGHT FOR: BUTT FRAME ASSY								SCALE	
DRAWN		OR: TRICHI ASSAULT RIFLE								STORE DRG. NO. K-6013	
CHECKED		DES. REF. NO.								OPERATION NO.	
HOS/DADDO		DRG. No.: TAR-RB-K-6013								SHEETS: 1	
OFFICER/PRODN		ORDNANCE FACTORY								SHEET No.: 1	
OFFICER/DRDO		TRUCHIRAPPALLI-16.									
AMENDMENTS		APPROVED ON:									
DATE											

DRG. NO. K-6012

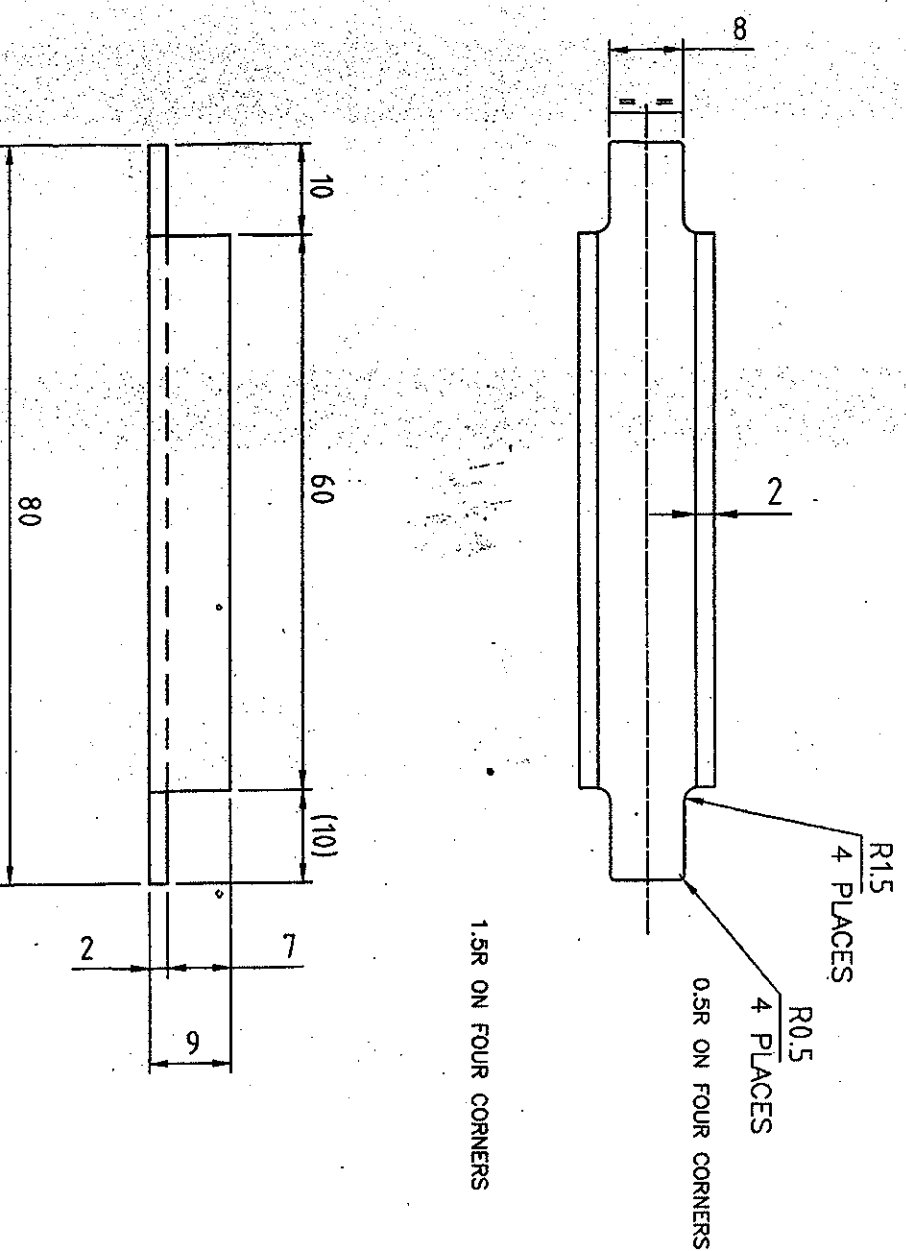

1.5R ON FOUR CORNERS

0.5R ON FOUR CORNERS

UN CONTROLLED COPY

Design & Drafting Office  
Ordnance Factory,  
Trichirappalli-601016

CERTIFICATE OF APPROVAL DRAWING  
AT THIS DATE 14/11/17

K-6012

MATERIAL : IS:7226 C40  
HARDNESS : 280-330 HV  
PROTECTIVE FINISH :  
PHOSPHATED TO SPECN WPN/GEN/3 CLASS II, OIL FINISH

G.Ka DGM NODAL OFFICER (TAR)		PART NO. DESCRIPTIONS		NO. OFF		MATERIAL		TREATMENT		REMARKS	
SIGNATURE & DATE		SUB: SUPPORT CHANNEL RIGHT FOR: BUTT FRAME ASSY								SCALE	
DRAWN		OR: TRICHI ASSAULT RIFLE								STORE DRG. NO. K-6012	
CHECKED		DES. REF. NO.								OPERATION NO.	
HOS/DADDO		DRG. No.: TAR-RB-K-6012								SHEETS: 1	
OFFICER/PRODN		ORDNANCE FACTORY								SHEET No.: 1	
OFFICER/DRDO		TRUCHIRAPPALLI-16.									
AMENDMENTS		APPROVED ON:									
DATE											