

b spec updated

REFERENCE

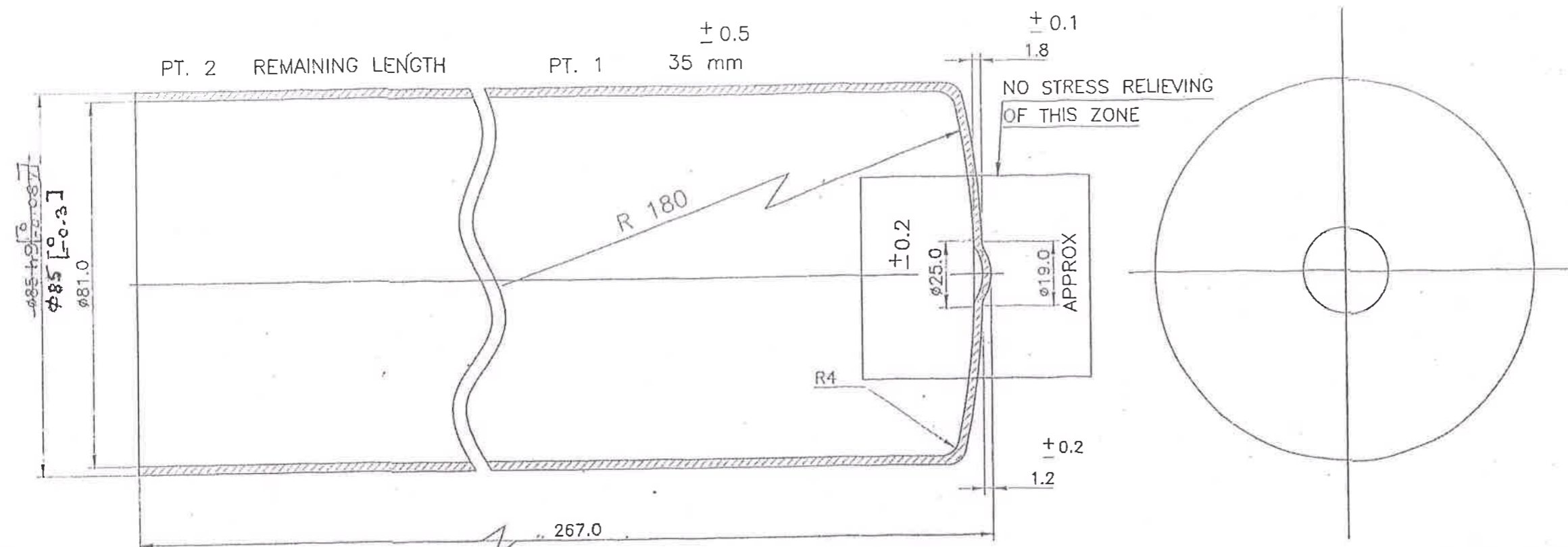

NOTES

1. CAN BE MANUFACTURED IN 2 PIECES
2. MATL. FOR PART 2:-ASTM 106 Gr.8 SEAMLESS TUBE
3. PART 1 DRG. AMENDED TO IS : 513:2008.EDD Gde CR4:
4. R-4 OPEN TOLERANCE
5. GENERAL TOLERANCE IS : 2102 TO BE APPLIED
6. PART 1 & PART 2 TO BE WELDED
7. AFTER WELDING WITH SLEEVE (NASK:1062/2) PNEUMATIC LEAK TEST AT 3 Kg/cm² FOR 01 MINUTE TO BE UNDERTAKEN.
8. CONCENTRICITY OF Pt 1 & Pt 2 TO BE MAINTAINED IN 0.1 MM.
9. WHEN MANUFACTURED IN SINGLE PIECE, MATERIAL IS: 513:2008 EDD Gde CR4, IS TO BE USED.
10. INTERMEDIATE STRESS RELIEVING TO BE CARRIED OUT AS PART OF DEEP DRAWING.
11. LINER TO BE HEAT TREATED AT TEMPERATURE 340° ± 10° FOR TWO HRS.

ISSUED BY
STANDARD CELL
f EOP
DATE: 7/11/11 SIGNATURE:

| | | | | | | | | |
|----------|-------|---------------------------------|--------------|----------------------|----------------------|---------------------------------|--------------------|---|
| 26-7-17 | C-D-8 | DIMENSION AMENDED | ARD2532 | SCALE: N T S | DIMENSIONS ARE IN mm | TOL | D.S.CAT No | ASSY.DRG. No.NASK 1062(P) |
| 22-09-15 | | MATL SPEC AMENDED & NOTES ADDED | ARD2484 | DGN. | DRN | COMP. | CHD. | ASSY.DRG.LIST No. |
| 22-6-15 | C-D-8 | DIMENSION AMENDED | ARD2479 | PASSED | APPROVED | THREADS TO CONFORM IS:4218 | | DTE GEN OF NAVAL ARMAMENT INSPECTION IHQ, MoD (NAVY), N:DELHI |
| 13-02-14 | | NOTE'S SL. NO 7 AMENDED | ARD2453 | CTO(D) | | GEN.SPEC: IS:2102 | | |
| 14-01-11 | | NOTE - 9 ADDED | ARD 2413 | MATL:- SEE DRG | | STORE SPEC. NO. | | |
| 02-06-09 | | APPROVED | DGNAI | MATL. SPEC:- SEE DRG | | STORE REF. No. | | |
| R.No | DATE | ZONE | BRIEF RECORD | AUTHORITY | INITIALS | PROTECTIVE FINISH. SEE ASSY DRG | GAUGE SCHEDULE No. | |

LINER

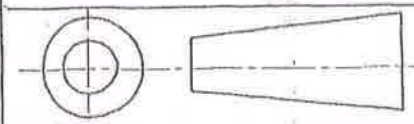

DRG.No.
NASK 1062/3
(PROVISIONAL)