

DIMENSIONS ARE IN mm.

MARKING (SUITABLY) ON SAMPLE/ TAG
 YR.OF Mfg.
 MANUFACTURER'S CODE
 DRG.NO

FINISH:-
 PHOSPHATE TO SPECIFICATION JSS 0465-01:1988
 CLASS II(ACCELERATED)OIL FINISH

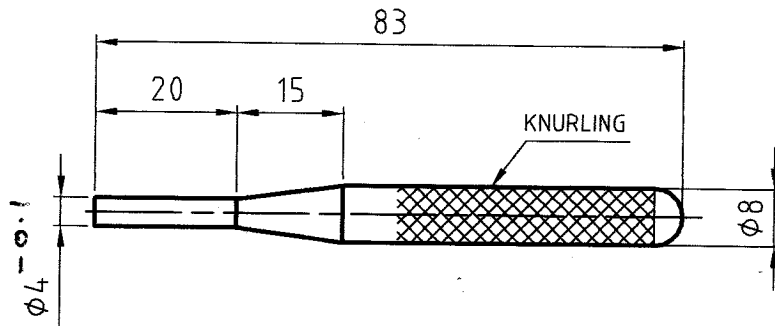

MATERIAL :- STEEL BS.970 PT.1:1983 Gr.070 M55

HARDNESS:- 425-475 H.V.

PART NO.	DESCRIPTIONS	NO OFF	MATERIAL	TREATMENT	REMARKS
	SIGNATURE & DATE.	SUB: PIN PUNCH 4mm			SCALE 1:1
	TRACED	FOR: TOOLS & ACCESSORIES			STORE DRG.NO.
	DRAWN <i>no. A. V. ...</i>	OF: 40mm MGL			-
	CHECKED <i>[Signature]</i>	DES.REF.NO.			OPERATION NO.
	OIC/D&DO <i>[Signature]</i>	DRG. No.: 30T 1700 013 A4			-
	OFFICER/ PRODN.	ORDNANCE FACTORY TIRUCHIRAPPALLI-16.			SHEETS: 1
	OFFICER/ D&DO				SHEET No.: 1
AMENDMENTS	SIG. & DATE	APPROVED ON. 20/12/2007			