

**HEXAGONAL BOLTS WITH
REDUCED HEAD
PRODUCT GRADE B**

Construction and dimensions

GOST 7796-70

Extract

**CONTRACT
№ PB/835606213601**

**HEXAGONAL BOLTS WITH REDUCED HEAD
PRODUCT GRADE B**

Construction and dimensions

GOST 7796-70

Extract

**HEXAGONAL BOLTS WITH
REDUCED HEADS PRODUCT
GRADE B**

**GOST
7796-70**

Extract

Construction and dimensions

1. Present standard deals with hexagonal bolts with reduced head of product grade B with thread diameter ranging from 8 to 48 mm.
2. Design and dimensions of bolts should correspond to those specified in drawing and in table 1 and 2.
3. Thread as per GOST 24705-81. Run out and undercut of thread – as per GOST 27148-86. Ends of bolts – as per GOST 12414-86.
4. Radius under the head – as per GOST 24670-81.
5. Tolerances for dimensions, deviation of shapes and location of surfaces and methods of checking, not established by the present standard, are as per GOST 1759.1-82.
6. Permissible surface defects of bolts and methods of checking are as per GOST 1759.2-82.
7. Bolts of make 1 and 2 with head height equal to k_1 , may be manufactured as per agreement between manufacturer and user.
8. Alternate make of heads are set by manufacturer.
9. Bolts, with diameter of smooth part of shank d_1 approximately equal to pitch diameter of threads, may be manufactured as per agreement between manufacturer and user.
10. Bolts of make 1 and 2 with rises on end face of surface of heads with dimensions, not reducing the strength of head may be manufactured for applying marking symbols, during this, the depth of rises should be not more than 0.4 k.
11. Technical requirements – as per GOST 1759.0-87.

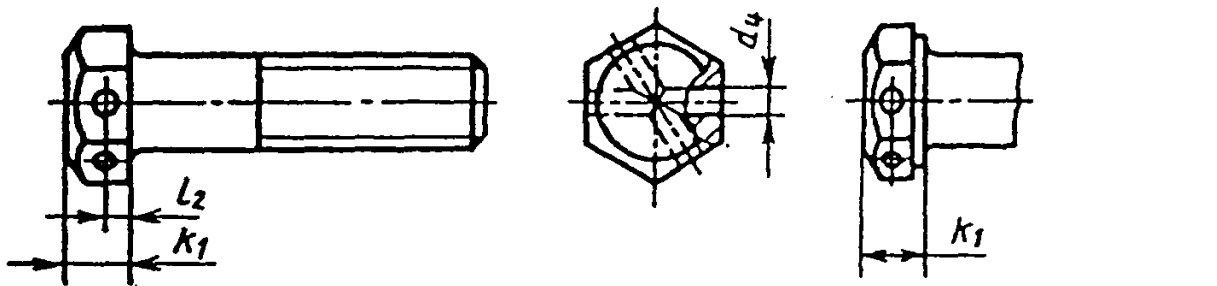
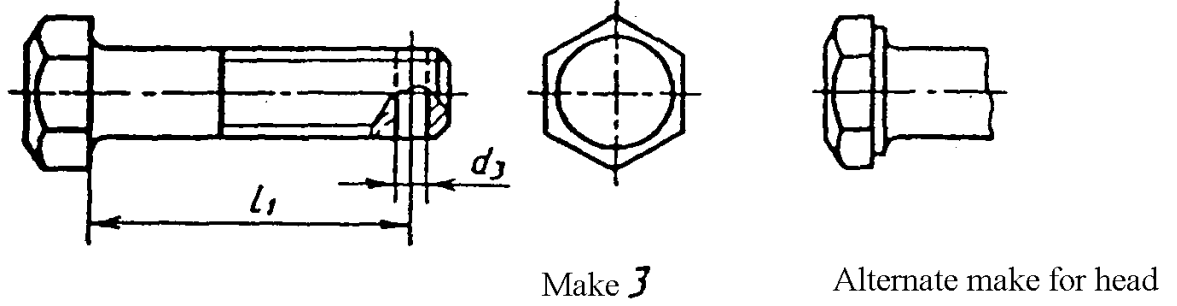
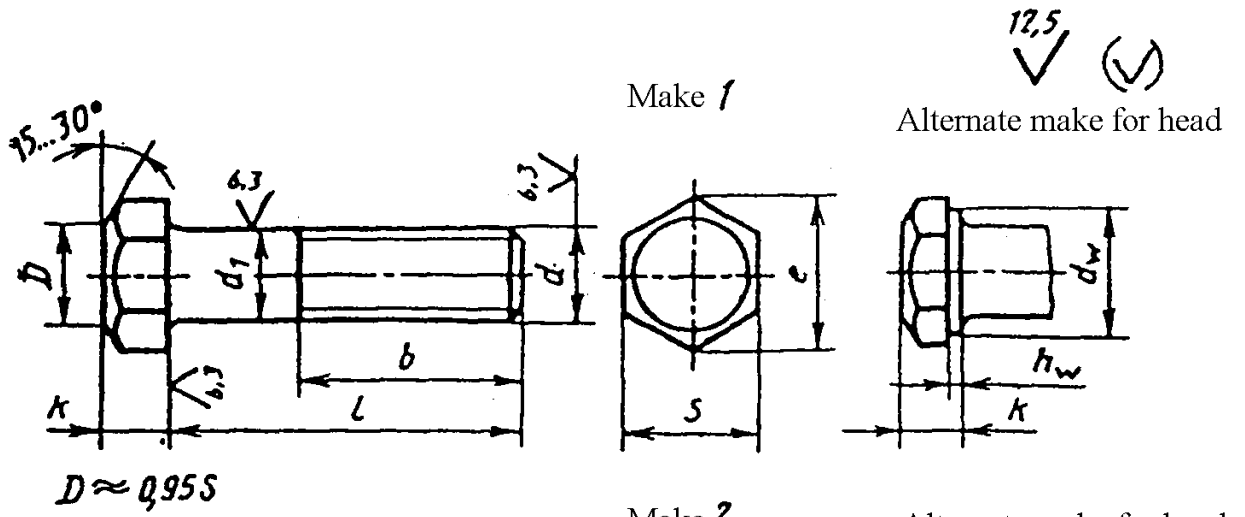

mm

Table 1

Nominal diameter of thread d		8	10	12	(14)	16	(18)	20	(22)	24	(27)	30	36	42	48
Thread pitch	Coarse	1.25	1.5	1.75	2	2	2.5	2.5	2.5	3	3	3.5	4	4.5	5
	Fine	1	1.25	1.25	1.5	1.5	1.5	1.5	1.5	2	2	2	3	3	3
Diameter of rod d ₁		8	10	12	14	16	18	20	22	24	27	30	36	42	48
Dimension <<for wrench>> S		12	14	17	19	22	24	27	30	32	36	41	50	60	70
Height of heads k		5	6	7	8	9	10	11	12	13	15	17	20	23	26
Height of head k ₁		5.3	6.4	7.5	8.8	10.0	12.0	12.5	14.0	15.0	17.0	18.7	22.5	26.0	30.0
Diameter of specified circumference e, not less than		13.1	15.3	18.7	20.9	23.9	26.2	29.6	33.0	35.0	39.6	45.2	55.4	66.4	76.9
d _w , not less than		10.5	12.5	15.5	17.2	20.1	22.0	24.8	27.7	29.5	33.2	38.0	46.6	55.9	64.7
h _w	not less than	0.15				0.20							0.25		
	not more than	0.6													
Diameter of hole in rod d ₃		2.0	2.5	3.2		4.0			5.0			6.3		8.0	
Diameter of hole in head d ₄ (deviation limit H15)		2.5		3.2		4.0						5.0			
Distance between supporting surface and axis of hole in head l ₂ (deviation limit js15)		2.8	3.5	4.0	4.5	5.0	6.0	6.5	7.0	7.5	8.5	9.5	11.5	13.0	15.0

Note: Dimensions of bolts, specified in brackets, are not recommended to use.

Dimensions in mm

Table 2

Length of thread b and distance from supporting surface of head to the axis of hole in shank l_1 , during nominal diameter of thread d (bolts with thread along the entire length of shank are marked with symbol X)

Length of bolts l	8		10		12		(14)		16		(18)		20		(22)		24		(27)		30		36		42		48	
	l_1	b	l_1	b	l_1	b	l_1	b	l_1	b	l_1	b	l_1	b	l_1	b	l_1	b	l_1	b	l_1	b	l_1	b	l_1	b	l_1	b
	8	—	X	—	—	—	—	—	—	—	—	—	—	—	—	—	—	—	—	—	—	—	—	—	—	—	—	—
10	—	X	—	X	—	—	—	—	—	—	—	—	—	—	—	—	—	—	—	—	—	—	—	—	—	—	—	—
12	—	X	—	X	—	—	—	—	—	—	—	—	—	—	—	—	—	—	—	—	—	—	—	—	—	—	—	—
14	—	X	—	X	—	X	—	—	—	—	—	—	—	—	—	—	—	—	—	—	—	—	—	—	—	—	—	—
16	12	X	—	X	—	X	—	X	—	—	—	—	—	—	—	—	—	—	—	—	—	—	—	—	—	—	—	—
(18)	14	X	14	X	—	X	—	X	—	X	—	X	—	—	—	—	—	—	—	—	—	—	—	—	—	—	—	—
20	16	X	16	X	15	X	—	X	—	X	—	X	—	—	—	—	—	—	—	—	—	—	—	—	—	—	—	—
(22)	18	X	18	X	17	X	17	X	—	X	—	X	—	—	—	—	—	—	—	—	—	—	—	—	—	—	—	—
25	21	X	21	X	20	X	20	X	19	X	—	X	—	X	—	—	—	—	—	—	—	—	—	—	—	—	—	—
(28)	24	X	24	X	23	X	23	X	22	X	—	X	—	X	—	—	—	—	—	—	—	—	—	—	—	—	—	—
30	26	X	26	X	25	X	25	X	24	X	—	X	—	X	—	—	—	—	—	—	—	—	—	—	—	—	—	—
(32)	28	X	28	X	27	X	27	X	26	X	—	X	—	X	—	X	—	X	—	—	—	—	—	—	—	—	—	—
35	31	X	31	X	30	X	30	X	29	X	—	X	—	X	—	X	—	X	—	—	—	—	—	—	—	—	—	—
(38)	34	X	34	X	33	X	33	X	32	X	—	X	—	X	—	X	—	X	—	X	—	—	—	—	—	—	—	—
40	36	X	36	X	35	X	35	X	34	X	—	X	—	X	—	X	—	X	—	X	—	X	—	—	—	—	—	—
45	41	X	41	X	40	X	40	X	39	X	—	X	—	X	—	X	—	X	—	X	—	X	—	—	—	—	—	—
50	46	X	46	X	45	X	45	X	44	X	—	X	—	X	—	X	—	X	—	X	—	X	—	—	—	—	—	—
55	51	X	51	X	50	X	50	X	49	X	—	X	—	X	—	X	—	X	—	X	—	X	—	—	—	—	—	—
60	56	X	56	X	55	X	55	X	54	X	—	X	—	X	—	X	—	X	—	X	—	X	—	—	—	—	—	—
65	61	X	61	X	60	X	60	X	59	X	—	X	—	X	—	X	—	X	—	X	—	X	—	—	—	—	—	—
70	66	X	66	X	65	X	65	X	64	X	—	X	—	X	—	X	—	X	—	X	—	X	—	—	—	—	—	—
75	71	X	71	X	70	X	70	X	69	X	—	X	—	X	—	X	—	X	—	X	—	X	—	—	—	—	—	—
80	76	X	76	X	75	X	75	X	74	X	—	X	—	X	—	X	—	X	—	X	—	X	—	—	—	—	—	—
(85)	81	X	81	X	80	X	80	X	79	X	—	X	—	X	—	X	—	X	—	X	—	X	—	—	—	—	—	—
90	86	X	86	X	85	X	85	X	84	X	—	X	—	X	—	X	—	X	—	X	—	X	—	—	—	—	—	—
(95)	91	X	91	X	90	X	90	X	89	X	—	X	—	X	—	X	—	X	—	X	—	X	—	—	—	—	—	—
100	96	X	96	X	95	X	95	X	94	X	—	X	—	X	—	X	—	X	—	X	—	X	—	—	—	—	—	—
(105)	—	—	101	X	100	X	100	X	99	X	—	X	—	X	—	X	—	X	—	X	—	X	—	—	—	—	—	—
110	—	—	105	X	105	X	105	X	104	X	—	X	—	X	—	X	—	X	—	X	—	X	—	—	—	—	—	—
(115)	—	—	111	X	110	X	110	X	109	X	—	X	—	X	—	X	—	X	—	X	—	X	—	—	—	—	—	—
120	—	—	116	X	115	X	115	X	114	X	—	X	—	X	—	X	—	X	—	X	—	X	—	—	—	—	—	—

Dimensions in mm

Table 2

Length of bolts l	Length of thread b and distance from supporting surface of head to the axis of hole in shank l_1 during nominal diameter of thread d (bolts with thread along the entire length of shank are marked with symbol X)																											
	8		10		12		(14)		16		(18)		20		(22)		24		(27)		30		36		42		46	
	l_1	b	l_1	b	l_1	b	l_1	b	l_1	b	l_1	b	l_1	b	l_1	b	l_1	b	l_1	b	l_1	b	l_1	b	l_1	b	l_1	b
(125)	—	—	121	26	120	30	120	34	119	38	119	42	119	46	118	50	118	54	117	60	116	66	115	78	113	90	113	102
130	—	—	126	32	125	36	125	40	124	44	124	48	124	52	123	56	123	60	122	66	121	72	120	84	118	96	118	108
140	—	—	136	32	135	36	135	40	134	44	134	48	134	52	133	56	133	60	132	66	131	72	130	84	128	96	128	108
150	—	—	146	32	145	36	145	40	144	44	144	48	144	52	143	56	143	60	142	66	141	72	140	84	138	96	138	108
160	—	—	156	32	155	36	155	40	154	44	154	48	154	52	153	56	153	60	152	66	151	72	150	84	148	96	148	108
170	—	—	166	32	165	36	165	40	164	44	164	48	164	52	163	56	163	60	162	66	161	72	160	84	158	96	158	108
180	—	—	176	32	175	36	175	40	174	44	174	48	174	52	173	56	173	60	172	66	171	72	170	84	168	96	168	108
190	—	—	186	32	185	36	185	40	184	44	184	48	184	52	183	56	183	60	182	66	181	72	180	84	178	96	178	108
200	—	—	196	32	195	36	195	40	194	44	194	48	194	52	193	56	193	60	192	66	191	72	190	84	188	96	188	108
220	—	—	—	—	215	49	215	53	214	57	214	61	214	65	213	69	213	73	212	79	211	85	210	97	208	109	208	121
240	—	—	—	—	235	49	235	53	234	57	234	61	234	65	233	69	233	73	232	79	231	85	230	97	228	109	228	121
260	—	—	—	—	255	49	255	53	254	57	254	61	254	65	253	69	253	73	252	79	251	85	250	97	248	109	248	121
280	—	—	—	—	—	—	275	53	274	57	274	61	274	65	273	69	273	73	272	79	271	85	270	97	268	109	268	121
300	—	—	—	—	—	—	295	53	294	57	294	61	294	65	293	69	293	73	292	79	291	85	290	97	288	109	288	121

Note:

1. Bolts with dimensions of length, specified in brackets, are not recommended to use.
2. Bolts, for which value b is located above the thick line, may be manufactured with thread length upto head.

Example of conventional designation of bolt for make 1, having diameter of thread $d = 12$ mm, length $l = 60$ mm, having coarse pitch of thread with tolerance field 6g, strength class 5.8 without coating.

Bolt M12-6g x 60.58 GOST 7796-70

Same with, make 2, having fine pitch of thread with tolerance field 6g, strength class 10.9, made from steel grade 40X, with coating thickness 6 microns:

Bolt 2M12x1.25-6g x 60.10.9.40X.016 GOST 7796-70