

19-8-59	24476-5A	PROFORMA DRAWG, FINISH REDUCED, SEE RE-TRACE AND COPY TO 1005-00062							DRN: SCALE:- 1:1	KHO.	IND. STANDA. EST. MASS.	COMP. CHECKED	ANSP. CO(SA) ICHAPUR
									DATE: 19.8.59	APPROVED: 01.10.12/29	NEG. RE-TRACED.		ASSY. 1005-000627
													DRN'S REG. CISA 179/1
													PART NO.
													DRS. NO.
													D.S. CAT. NO. 1005-000628
NOMENCLATURE:- CRADLE ASSEMBLY.										PROTECTIVE FINISH.			

1005-000631

ON D.S. CAT. DIMNS. ARE IN mm.

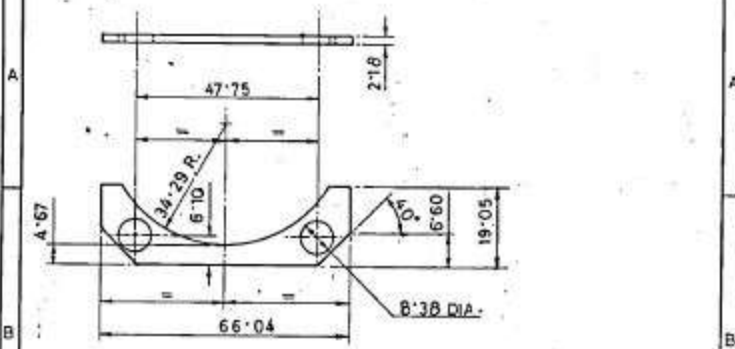

FOR EXPLANATION OF DETAILS WHEREVER NOT SPECIFIED REFER DD. NOTE SHEET NO. 3 (LATEST ISSUE).

ALT. MATL. - ACRYLONITRILE BUTADIENE RUBBER COMPOUNDS TO SPECN. IND/ME/91A (PROV.).

METRIC

C 02-4-96		23310-54	RESPONSE CHANGED. TOLERANCE HAVE ADHERED. NEG. RE-TRACED & PRG. RE-SEALED. PREVIOUS D.C. NOS. 11903-SA, B161-SA, B600-SA, 16259-SA, 16750-SA, 17722-SA & 22257-SA.	copy
DATE	AUTHY.	BRIEF	RECORD	ZONE
SEALED:	D.C.	17 732-SA,	DT. 22, 10, 63	WC D, DG, O.
DN	KND	TRD	SHANDEL	COMP
SCALE:-	1:1	EST. MASS.	2 GRAMS.	ASSY.
MFG/NSP INSTRUCTIONS.	APPROVED. DT. 10.12.69		NEG. RE-TRACED	
DI. 12-4-96	Shallu	I/C, D.O.		
MATERIAL.	VULCANISED BUTADIENE ACRYLONITRIL RUBBER COMPO-NENTS TO SPECN. BS-2751 BA-3		AHSP	CQA(SA) ICHAPUR
H.T./HARDNESS			DGNR'S REF.	CISA 179/34
PROTECTIVE			PART NO.	
FINISH			ORG. NO.	
NOMENCLATURE	EXCLUDER, DUST		D.S. CAT. NO.	1005 000631

Create PDF files without this message by purchasing novaPDF printer (<http://www.novapdf.com/>)

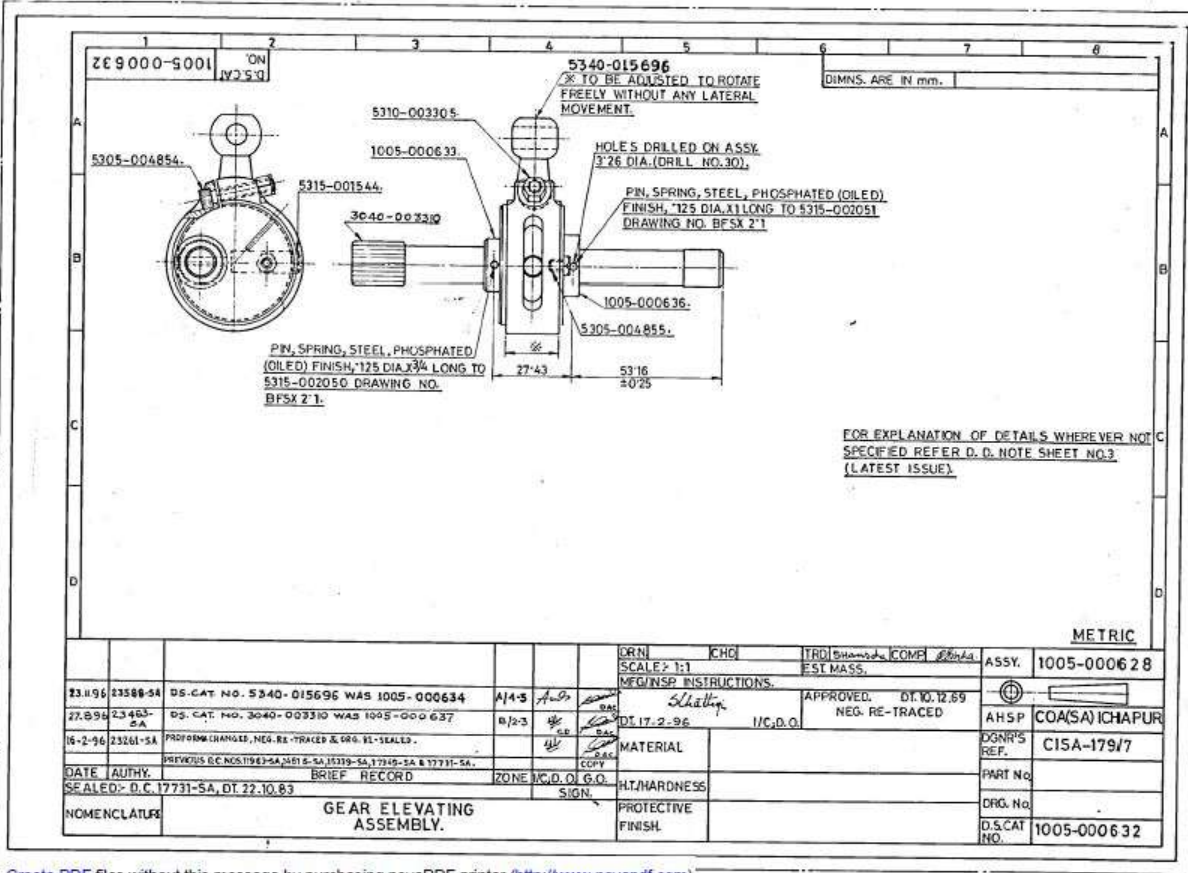

				DRN	CHC	TRD	Sharma	COMP	Sharma	ASSY.	1005-000628
				SCALE: 1:1			EST. MASS.				
				MFG/NSP INSTRUCTIONS.			APPROVED. DT. 10.12.89				
23-11-96	23588-SA	DS. CAT. NO. 5340-015696 WAS 1005-000634	A/1-3	A/S	Sharma	DT. 17-2-96	I/C, D.O.	NEG. RE-TRACED	AHSP	COA(SA) ICHAPUR	
27-09-94	23463-SA	DS. CAT. NO. 3040-003310 WAS 1005-000637	B/2-3	Sharma					DGNP'S REF.	CISA-179/7	
16-2-96	23261-SA	PERFORM CHANGED, NEG. RE-TRACED & DRG. IS SEALED.		Sharma					PART No.		
DATE	AUTHY.	BRIEF RECORD	ZONE	M.C.D.	O.G.O.	HT./HARDNESS			DRG. No.		
SEALED:	D.C. 17731-SA, DT. 22.10.83			SIGN.		PROTECTIVE FINISH.			D.S.CAT NO.	1005-000632	
NOMENCLATURE		GEAR ELEVATING ASSEMBLY.									

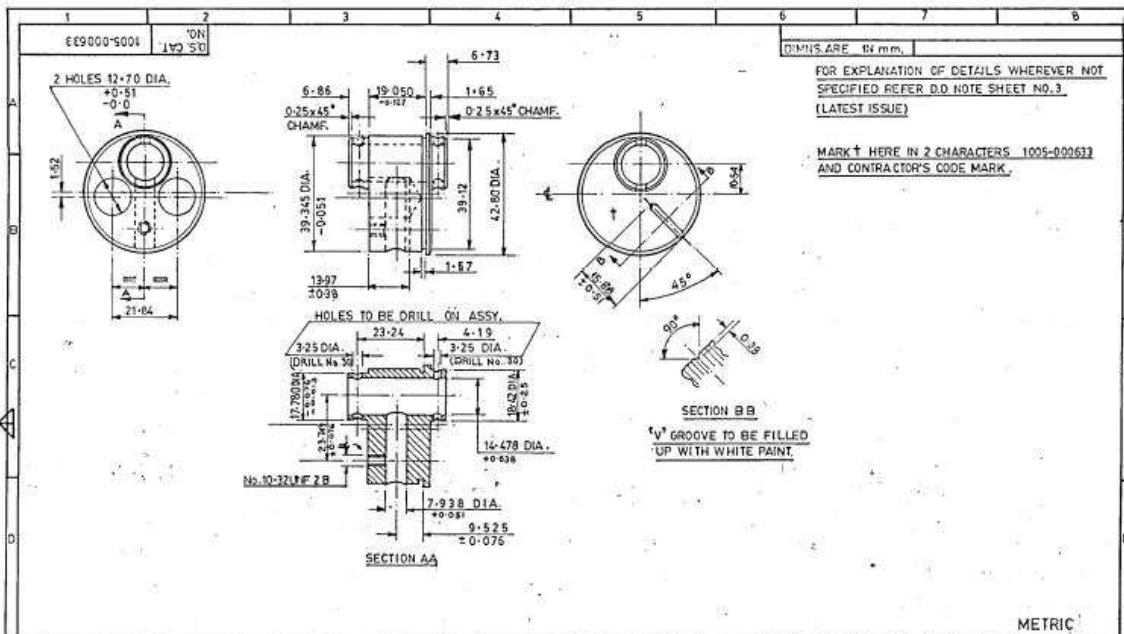

DIMENSIONS IN mm.
 FOR EXPLANATION OF DETAILS WHEREVER NOT SPECIFIED REFER D.O NOTE SHEET NO.3 (LATEST ISSUE)

MARK † HERE IN 2 CHARACTERS 1005-000632 AND CONTRACTOR'S CODE MARK.

SECTION BB
 V GROOVE TO BE FILLED UP WITH WHITE PAINT.

METRIC

DRN	CHD	TRD	COMP	Number	ASSY.	1005-000632
SCALE: 1-1.1	MFG/INSP. INSTRUCTION		APPROVED DT. 10.12.69		AHSP	
DT. 22-11-95		1/C: D.O.		NEG RE-TRACED		CQA/SA/CHAPUR
4-11-95	23135-SA	NEG RE-TRACED, EXPLANATION NOTE & PROTECTIVE FINISH APPLIED AND DRG. BE RE-RELEASED.		PREVIOUS DC NO. 11963-SA, 15395-SA, 17357-SA, 17805-SA, 17737-SA AND 17616-SA		DGR'S REF. CISA 179/20/1
DATE AUTH.	BRIEF RECORD	ZONE	I/C, D.O.	G.O.	COPY	PART NO.
SEALED:-	D.C. NO. 17737-SA	DT. 31.10.83.		SIGN.		H.T./HARDNESS
NOMENCLATURE		CAM ELEVATING		PROTECTIVE FINISH		PHOSPHATE TO SPECN. JSS:0465-01:1988 CLASS B, OIL FINISH
						DRG. NO.
						D.S. CAT. NO. 1005-000633

989000 - 001 'ON
D.S. CAT. 1005 - 000636

DIMNS. ARE IN mm.

FOR EXPLANATION OF DETAILS WHEREVER
NOT SPECIFIED REFER D.D. NOTE SHEET NO 3
(LATEST ISSUE).

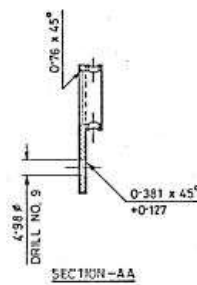
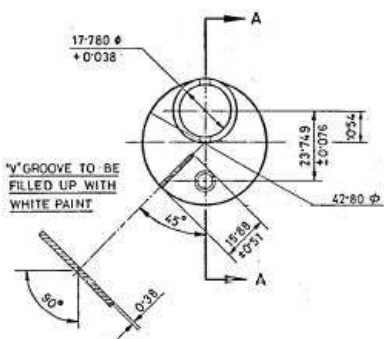
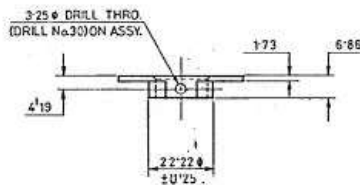

METRIC

DRN. CHD TRD COMP. 3.1.1		AHSP CQA(SA) CHAPUR	
SCALE :- 1:1		EST. MASS :- 20 GRAMS	
DT. 9-2-06		APPROVED DT. 10-12-69	
MATERIAL :- BS-970 PT. 1:1983 Gr. 070 M55		NEG. RE-TRACED.	
3-3-06	26167 - SA	PROFORMA CHANGED, PROTECTIVE FINISH & TOL. NOTE AMENDED, NEG. RE-TRACED AND DRG. RE-SEALED.	ASSY. 1005-000632
		PREVIOUS D.L. NO. 11963-SA, 15356-SA, 17680-SA, 17737-SA & 19608-SA	OGNRS REF. CISA 179/21/1
DATE AUTHY	BRIEF RECORD	ZONE	PART NO.
SEALED :- D.C. 17737-SA DT. 31-10-83		UC/D.O. G.O. STGN.	DRG. NO.
NOMENCLATURE :- PLATE, RETAINING HOUSING		PROTECTIVE FINISH :- PHOSPHATE TO SPECN. JSS 0465-01-1994, CLASS D (ACCELERATED) OIL FINISH.	
		D.S. CAT. NO. 1005-000636	

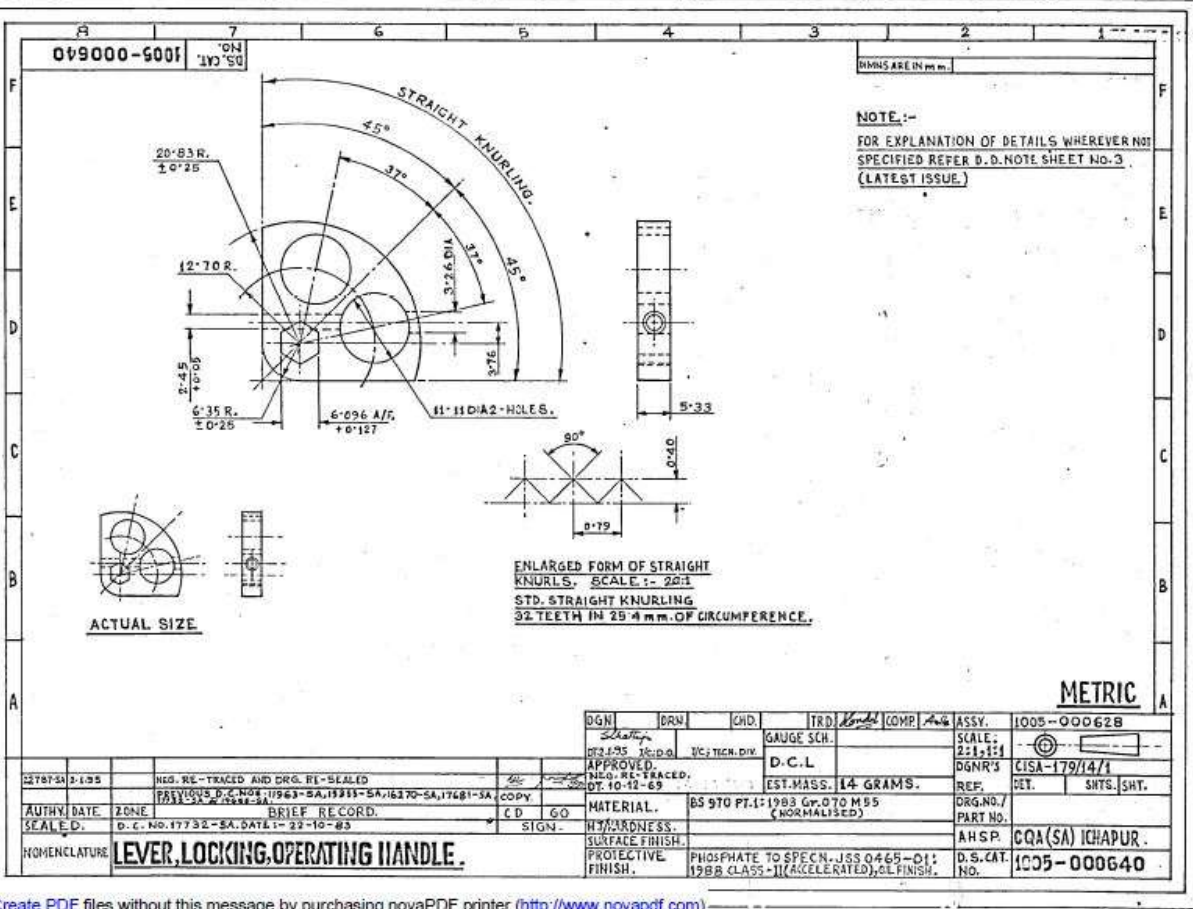

227875A	2-135	NEG. RE-TRACED AND DRG. RE-SEALED			
AUTHY. DATE:	ZONE:	BRIEF RECORD.	COPY	CD	GO
SEALED:	D. C. No. 17732 - SA. DATE 1-22-10-85				
NOMENCLATURE: LEVER, LOCKING OPERATING HANDLE.					

DGN	DRN	CHD.	TRD.	COMP.	ASSY.	1005-000628
DR2.125	IC: D.O.	IC: TEN. DIV.	GAUGE SCH.		SCALE: 2:1	
APPROVED.			D. C. L.		DGNR'S	CISA-179/14/1
NEG. RE-TRACED.				EST. MASS. 14 GRAMS.	REF.	DET. SHTS. SHT.
DT. 10-12-69				MATERIAL.	BS 970 PT. 1: 1983 Gr. 070 M 55	ORG. NO. / PART NO.
				(NORMALISED)		AH S.P.
				HARDNESS.		CQA (SA) ICHAPUR.
				SURFACE FINISH.		D. S. CAT. NO.
				PROTECTIVE FINISH.	PHOSPHATE TO SPECN. JSS Q465-01	1005-000640
					12BB CLASS-II (ACCELERATED) CL FINISH.	

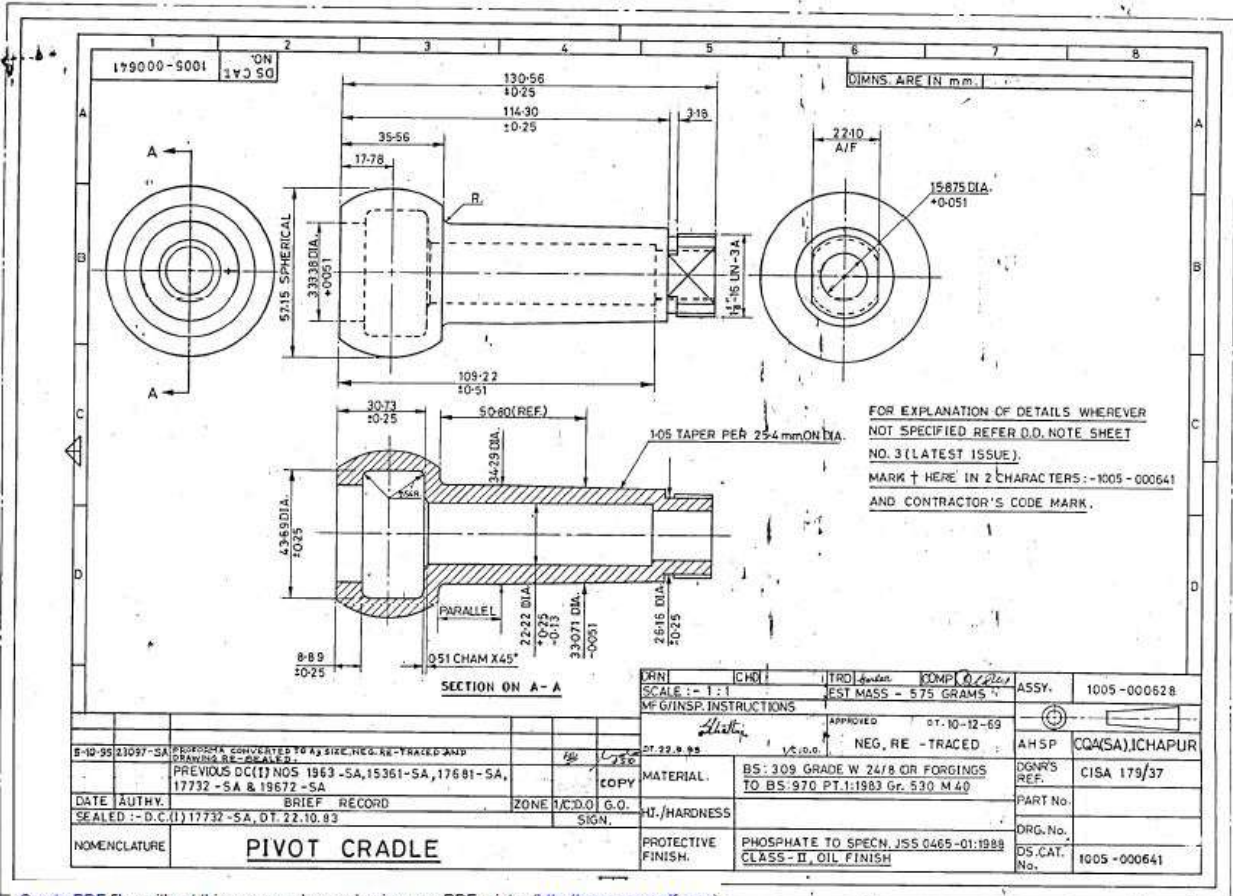

279000-5001

ALL DIMENSIONS ARE IN mm.

FOR EXPLANATION OF DETAILS WHEREVER NOT SPECIFIED, REFER TO NOTE SHEET NO. 1 (LATEST ISSUE)

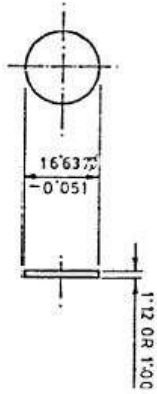

06-03-06/26169-5A		PROFORMA CHANGED TO NOTE AND PROTECTIVE FINISH AMENDED, NEG. RE-TRACTED & DRG. REF. SEALED.	
DATE	AUTHY.	PREVIOUS D.C. NO. 11983-SA/11983-SA/1781-5A	PREPARED BY
SCALE: 1:1	CHD.	TRD. 22.10.83	COMP. SQ. 1
D.N.	EST. MASS: 2 GRAMS.	APPROVED	DI: 10.12.69
MATERIAL: BS 1449 Pt. 1: 1972 Gr. CR 34/70 SECTIONS IN CRCA CONDITION		I/CDD (NEG. RE-TRACTED)	
H.T./HARDNESS: -		REF. CISA-179/38	
PROTECTIVE FINISH: -		PHOSPHATE TO SPEC. JSS 0465-011934 CLASS 1 (ACCELERATED), OIL FINISH.	
NOMENCLATURE: -		PLUG, EXPANSION	
DSCAT. NO. 1005-000642		PART. NO.	
ORG. NO.		SIGN.	

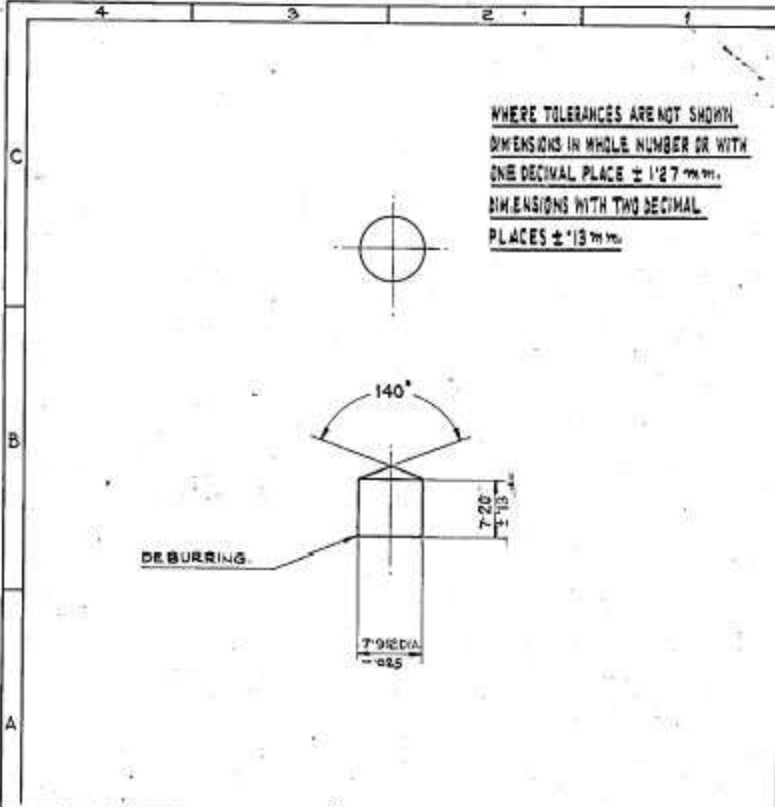

WHERE TOLERANCES ARE NOT SHOWN
 DIMENSIONS IN WHOLE NUMBER OR WITH
 ONE DECIMAL PLACE $\pm 1/27^{th}$ mm.
 DIMENSIONS WITH TWO DECIMAL
 PLACES $\pm 1/13^{th}$ mm.

METRIC

19669- 24	3.7.87	MATL. AMENDED		
17732- 24	23.10. 83	SEALED AS A RECORD OF RECEIPT CANCELLED & DRG. SEALED AS PER		
17706- 24	15.9. 87	MATL. AMENDED		
1524- 24	2.10.77	DS. CAT. NO. ADDED		
10403-5A	7.2.74	DRG. SEALED AS A RECORD OF RECEIPT		
AUTHY.	DATE	ZONE	BRIEF RECORD	SIG.
FOR EXPLANATION SEE DS NOTE SHEET NO.3				
DGN.	DATE	NAME	ASSY. DRG. NO. 1005-000628	CISA. ICHAPUR
DRU.			MATERIAL B3 970 DT 11783 Tm. 520 or 55 020001.400	
CD.			DIMENSIONS ARE IN MILLIMETRES	
TRD.		SOBARUA		
COMP.				
 K. L. K. K. IIC DO			PLUNGER, LOCKING, OPERATING HANDLE	APPROVED:- 10-12-89 FOR CISA DESIGNER'S REF. CISA. 179/39 DS. CAT. NO. 1005-000643
SEALED - 06/01/77/33-5A DT. 22.10.83				

Create PDF files without this message by purchasing novaPDF printer (http://www.novapdf.com)

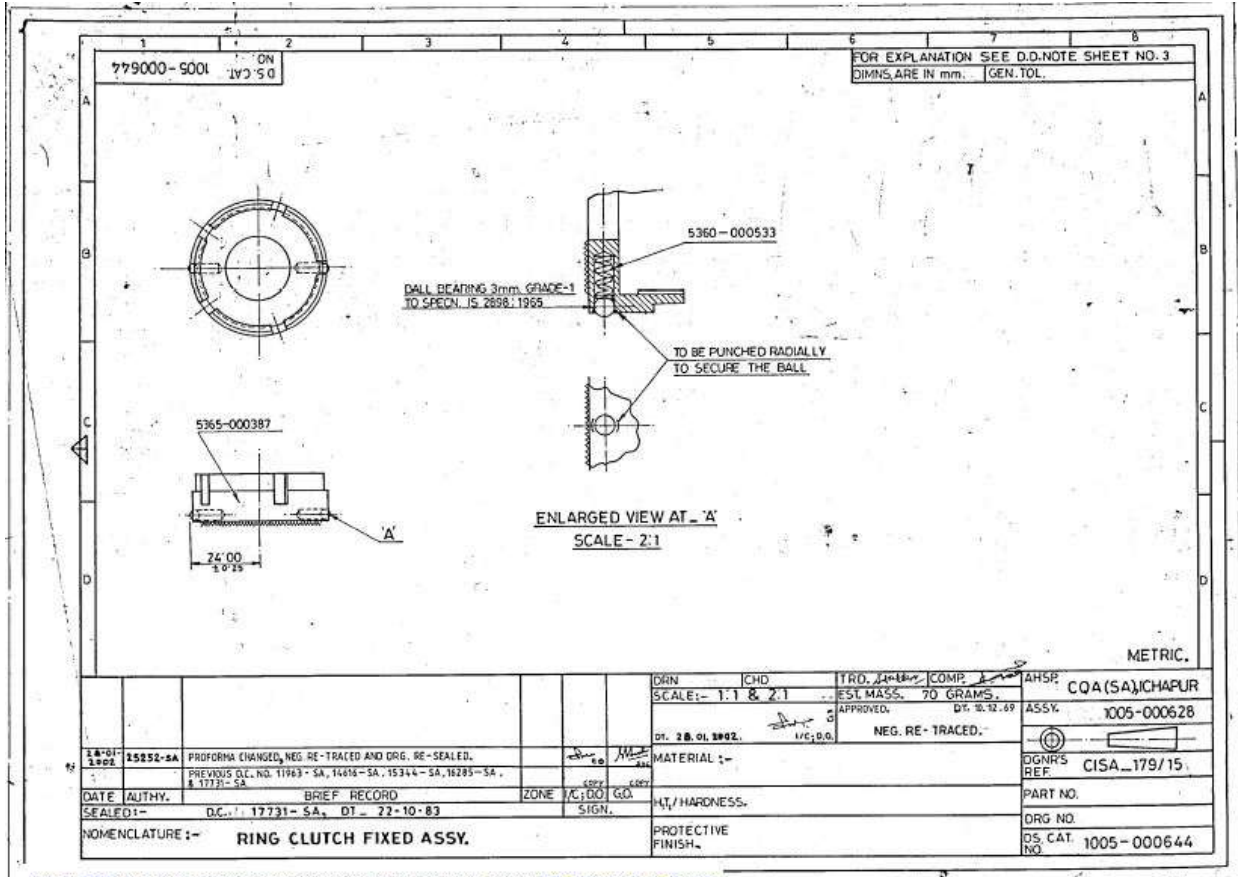

779000-5001		ON D.S. CAT. 50		FOR EXPLANATION SEE D.D.NOTE SHEET NO. 3 DIMNS. ARE IN mm. GEN. TOL.			
5365-000387		A'		5360-000533		METRIC.	
24.00 ± 0.25		A'		ENLARGED VIEW AT - A SCALE - 2:1			
15252-SA		PROFORMA CHANGED, NEG RE-TRACED AND DRG. RE-SEALED.		DRN [CHD] TRD. 14-10-83 [COMP] AHSE		CQA(SA)JCHAPUR	
PREVIOUS D.C. NO. 11963-SA, 14616-SA, 15344-SA, 16285-SA, 17731-SA		BRIEF RECORD		SCALE:- 1:1 & 2:1		EST. MASS. 70 GRAMS.	
DATE AUTHY. D.C. 17731-SA, DT - 22-10-83		SIGN.		APPROVED. DT. 10.12.89		ASSY. 1005-000628	
SEALING:-		ZONE		MATERIAL :-		NEG. RE-TRACED.	
NOMENCLATURE :- RING CLUTCH FIXED ASSY.		SIGN.		HT./HARDNESS.		DGNRS REF. CISA_179/15	
				PROTECTIVE FINISH.		PART NO.	
						DRG NO.	
						DS. CAT. NO. 1005-000644	

979000-0001 D.S.CAT. 1005-000628
 FOR EXPLANATION SEE D. D. NOTE SHEET NO. 3.
 DIMNS. ARE IN mm.

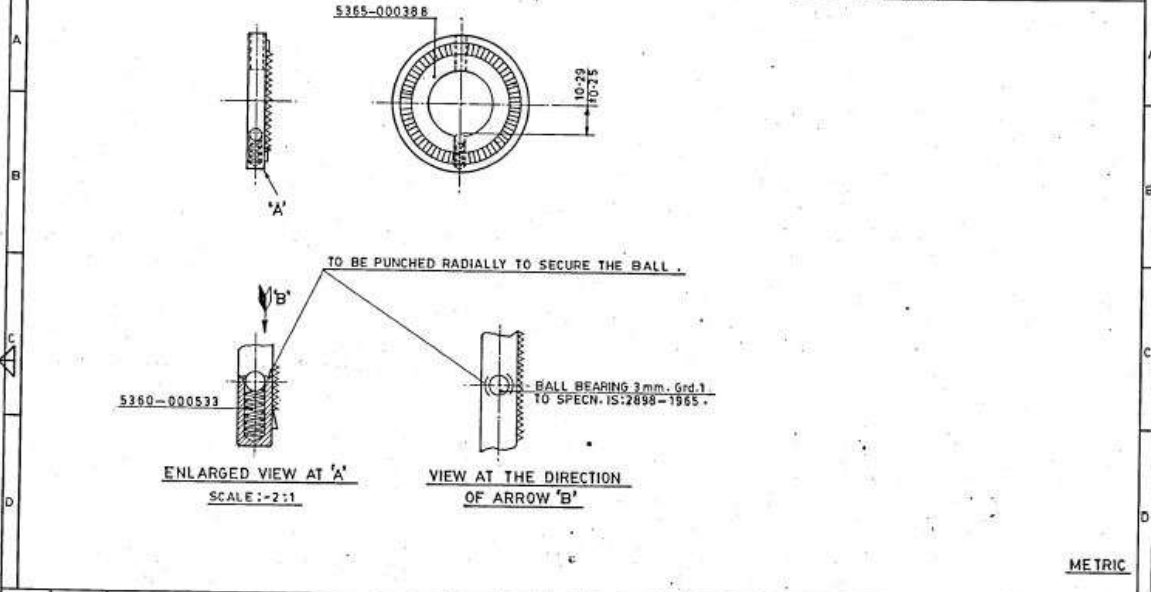

METRIC

DRN.	CHD.	TRD. Shaded	COMP. Marked	AHSP CQA(SA), ICHAPUR
SCALE: 1:1 & 2:1	EST. MASS:-	APPROVED. DT. 10.12.69	NEG. RE-TRACED	ASSY. 1005-000628
DT. 21-11-2001	IC, D.O.			
21-B-2001	2197-5A	PROFORMA CHANGED, NEG. RE-TRACED AND DRG. RE-SEALED.		DGNR'S REF CISA 179/16
DATE	AUTHY.	BRIEF RECORD		PART NO.
SEALED:-	D.C. NO. 17731-5A, DT. 22.10.83	ZONE	IC/D.O. G.O.	DRG. NO.
NOMENCLATURE:- RING CLUTCH SLIDING ASSY.				D.S.CAT. NO. 1005-000646
SIGN.				PROTECTIVE FINISH

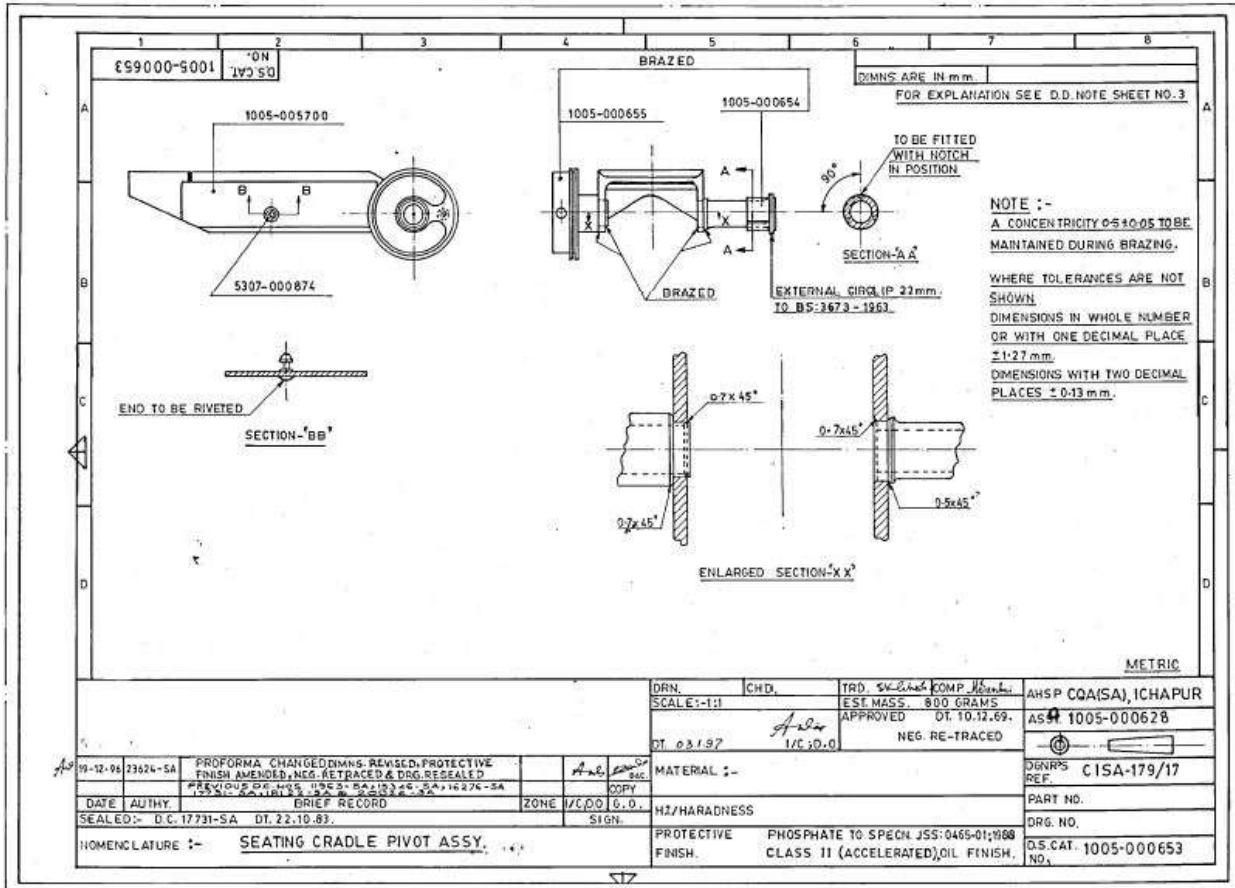

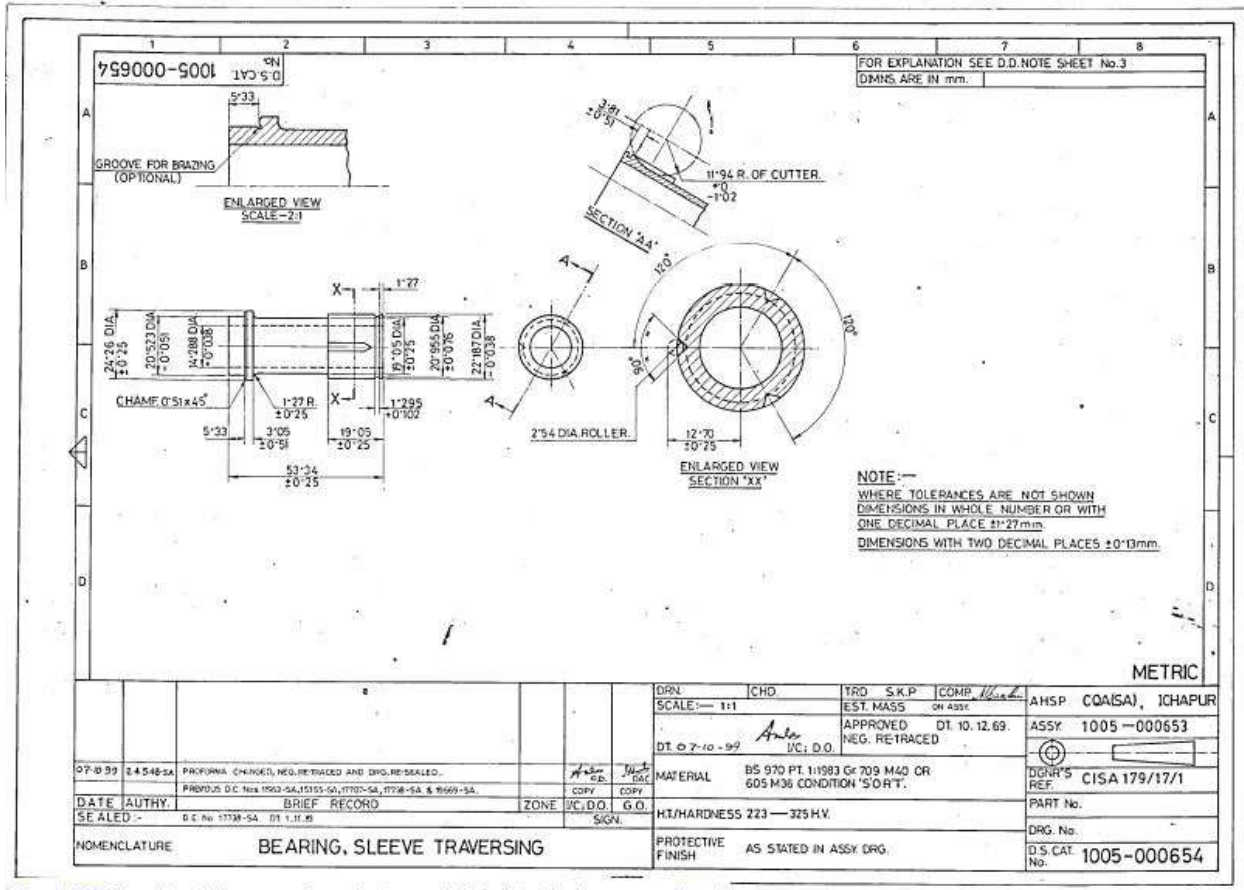

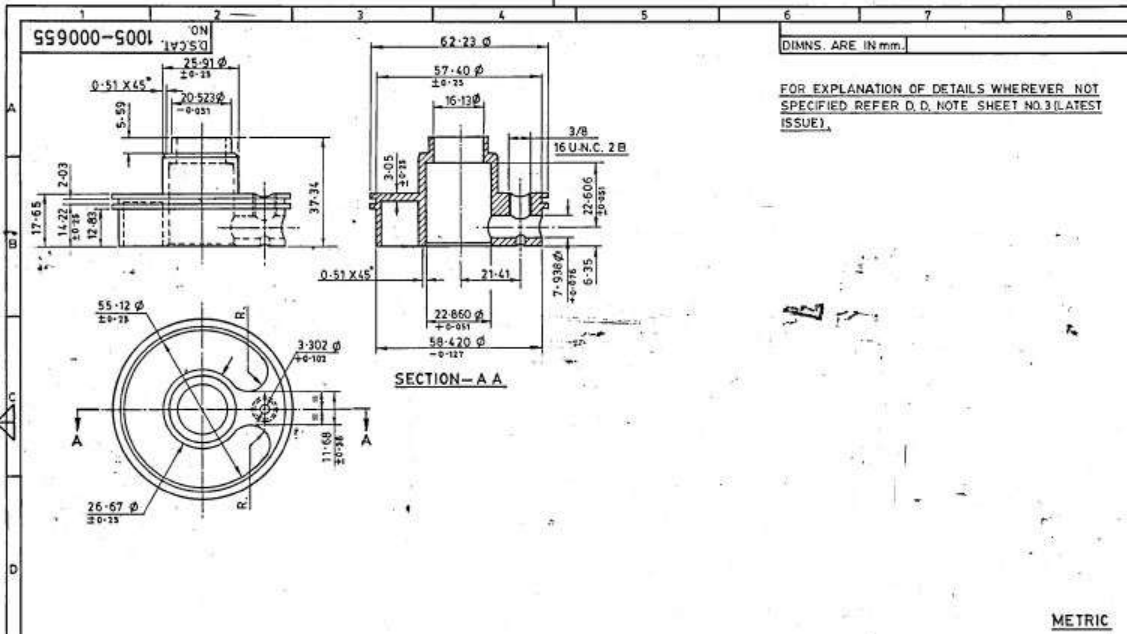

DRN.	CHD.	TRD. <i>Shankar</i>	COMP. <i>...</i>	AHSP. CQA(SA), ICHAPUR
SCALE :- 1:1		EST. MASS. :- ON ASSY.		ASSY. 1005-000653
		APPROVED. DT. 10.12.89		
DT. 25-4-2003	<i>...</i>	(NEGATIVE RE-TRACED)		
25-4-2003 25733-5A	PROFORMA CHANGED, TOLERANCE NOTE AMENDED, NEGATIVE RE-TRACED AND DRAWING RE-SEALED.			CGNR'S REF. :- CISA. 179/17/2
	PREVIOUS D.C. NOS. 11963-5A, 15845-5A, 17707-5A, 17738-5A & 19663-5A			PART NO.
DATE AUTHY.	BRIEF RECORD	ZONE	I/C:D.O. G.O.	ORG. NO.
SEALED :- D.C. NO. 17738-5A, DT. 1.11.83			SIGN.	D.S. CAT. 1005-000655
NOMENCLATURE :- HOUSING, HANDLE OPERATING.				PROTECTIVE FINISH :- AS STATED ON ASSY.

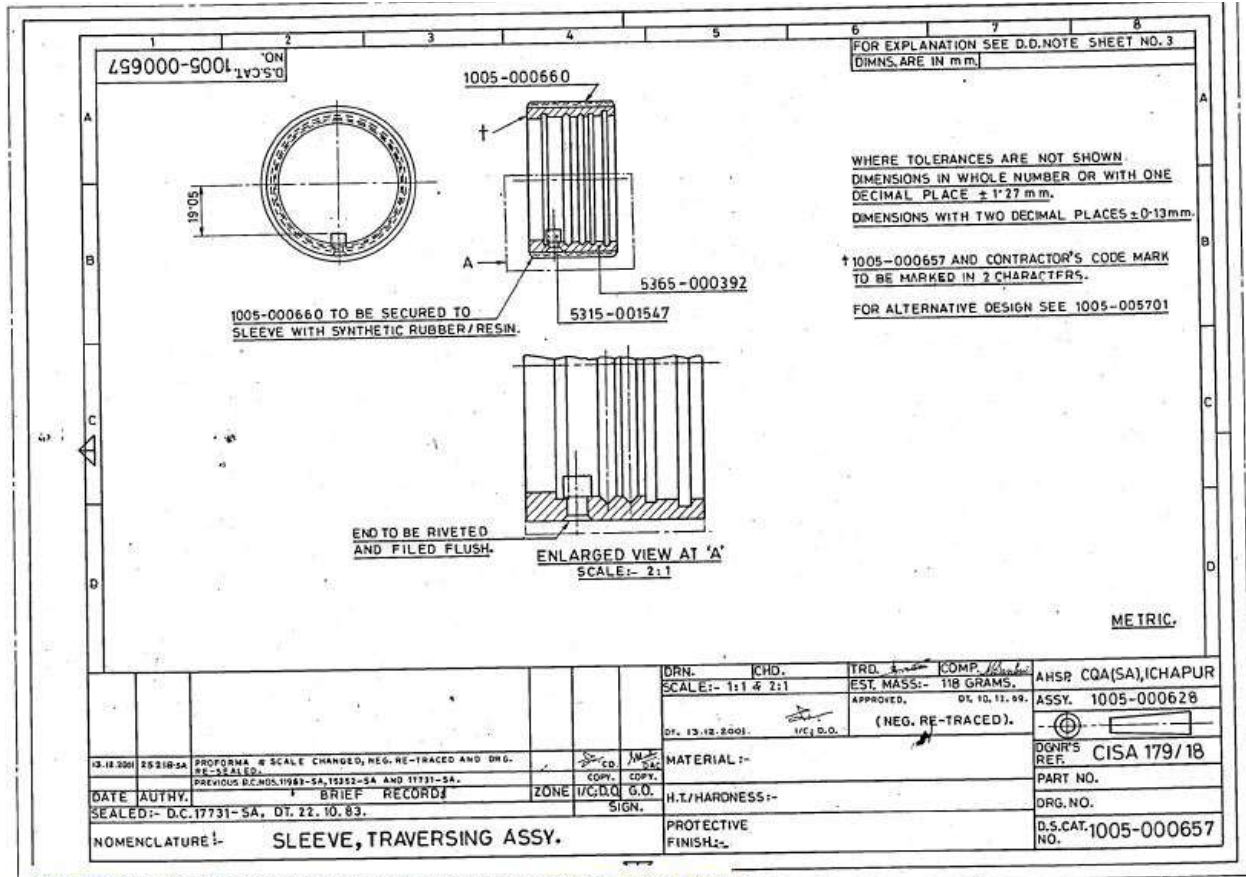

1005-000660		FOR EXPLANATION SEE D.D. NOTE SHEET NO. 3 [DIMNS. ARE IN mm.]	
1005-000660 TO BE SECURED TO SLEEVE WITH SYNTHETIC RUBBER/RESIN.		WHERE TOLERANCES ARE NOT SHOWN, DIMENSIONS IN WHOLE NUMBER OR WITH ONE DECIMAL PLACE ± 1.27 mm. DIMENSIONS WITH TWO DECIMAL PLACES ± 0.13 mm.	
5365-000392		† 1005-000657 AND CONTRACTOR'S CODE MARK TO BE MARKED IN 2 CHARACTERS.	
5315-001547		FOR ALTERNATIVE DESIGN SEE 1005-005701	
END TO BE RIVETED AND FILED FLUSH.		METRIC.	
ENLARGED VIEW AT 'A' SCALE:- 2:1			
DRN.	CHD.	TRD.	COMP. / 10.11.83
SCALE:- 1:1 & 2:1		EST. MASS:- 118 GRAMS.	
DT. 13.12.2001		APPROVED, 04.10.11.89	
		(NEG. RE-TRACED).	
MATERIAL :-		AHSP CQA(SA), ICHAPUR	
		ASSY. 1005-000628	
		DGNR'S REF. CISA 179/18	
		PART NO.	
		ORG. NO.	
		D.S.CAT. 1005-000657	
		NO.	
NOMENCLATURE :- SLEEVE, TRAVERSING ASSY.			

099000-COM

ON 1973 DIMNS. ARE IN mm.

FOR EXPLANATION OF DETAILS WHEREVER NOT SPECIFIED REFER D.D. NOTE SHEET 10.3 (LATEST ISSUE).

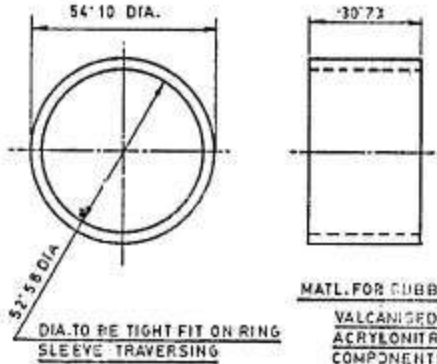

MATL. FOR RUBBER

VULCANISED BUTADIENE ACRYLONITRIL RUBBER COMPONENTS TO SPECN. BS 2751 BA-3

METRIC

13-03-06	26171-SA	PROFORMA CHANGED, TOL. NOTE AMENDED, NEG. RE-TRACED AND DRG. RE-SEALED.					
		PREVIOUS D.C.NOS. 11803-SA, 15259-SA, 15860-SA & 17018-SA.					
DATE	AUTHY	BRIEF RECORD	ZONE	P/C.D.O.	G.O.		
SEALED:-		D.C.NO. 17738 SA DT. 1.11.83.					
DRN.	CHD.	TRD.	COMP.	ANSP CQA(SA), ICHAPUR			
SCALE:- 1:1		EST. MASS:-		ASSY. 1005-000657			
DT. 13-03-06	IC/D.O.	APPROVED	DT. 10.12.83				
MATERIAL:-		AS STATED					
HT/HARDNESS:-				IGNR'S REF. CISA-179/18/3			
PROTECTIVE FINISH:-				PART. NO.			
				DRG. NO.			
NOMENCLATURE:-		SLEEVE SUPPORTING RING		D.S.CAT. NO. 1005-000660			

SCAN

Creates PDF files without this message by purchasing novaPDF printer (http://www.novapdf.com)

299000-5001 FOR EXPLANATION SEE DD FORM SHEET No. 3.
 DIMENSIONS ARE IN mm GEN. TOL

MARK IN 2 CHARACTERS:-
 1005-000662
 CONTRACTOR'S CODE MARK.

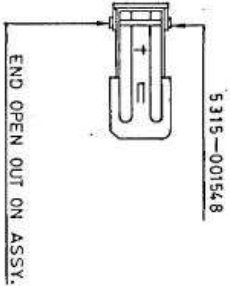
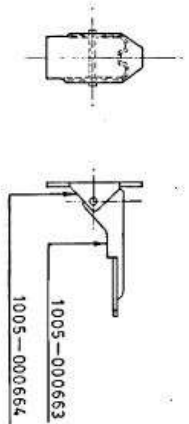

METRIC

4-5-2000 24710-SA	PROFORMA CHANGED, NEG. RE-TRACED AND DRG. RE-SEALED.		
DATE AUTHY	PREVIOUS D.C. NOS 11665-SA, 15343-SA, 16272-SA & 17231-SA.		
SEAL ED:- D.C. NO. 17231-SA	DT: 22.10.83.	BRIEF RECORD	
DRN	TRD	COMP	
SCALE: 1:2	APPROVED	EST. MASS. 36 GRAMS.	
DT: 4-5-2000	NEG. RE-TRACED	DT: 10.12.09	
MATERIAL		ASSY. 1005-000627	
H.T./HARDNESS		DGNR'S REF. CISA 179/11	
PROTECTIVE FINISH		PART No.	
NOMENCLATURE	DEFLECTOR CASE ASSY	DRG. NO.	
		D.S. CAT. NO.	1005-000662

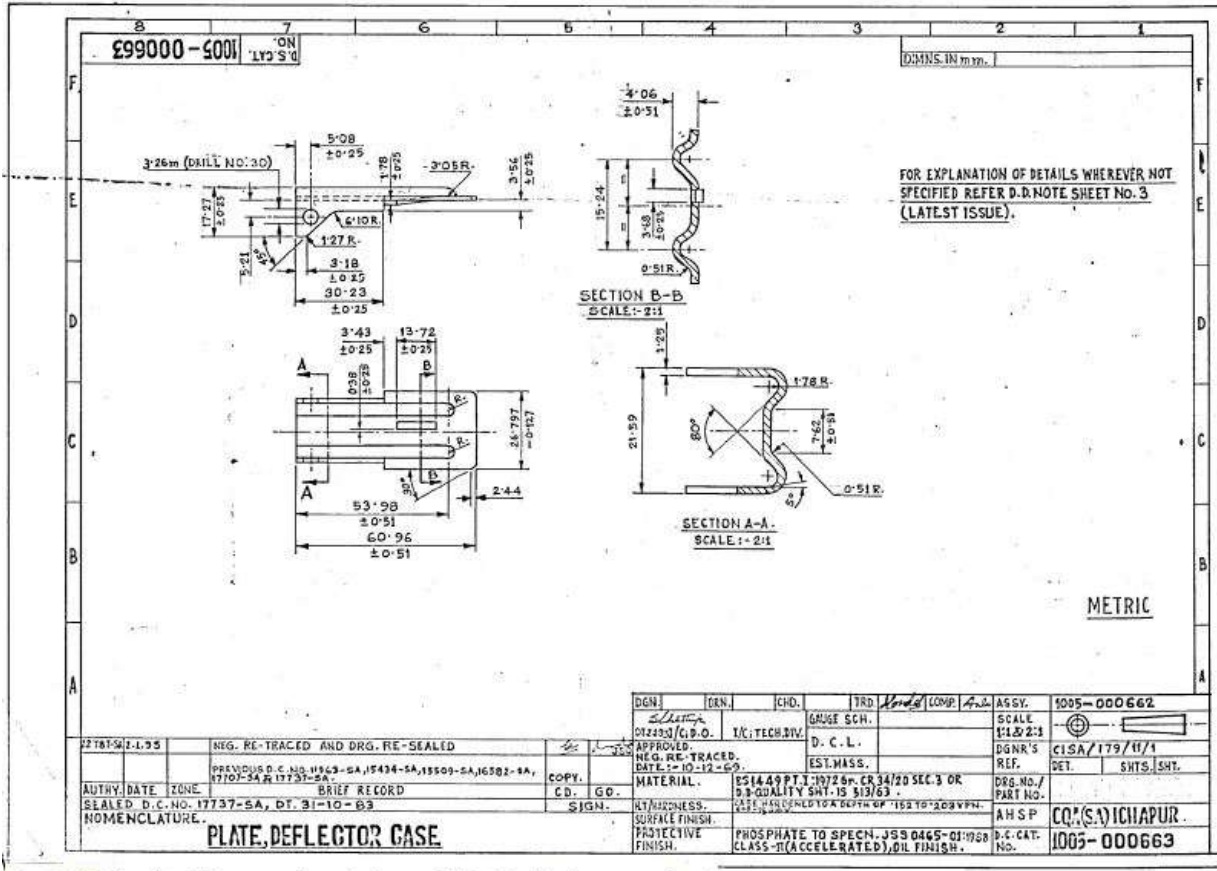

79 9000-5001

NON DIMENSIONS ARE IN mm.

FOR EXPLANATION OF DETAILS WHEREVER NOT SPECIFIED, REFER D.D. NOTE SHEET NO.3. (LATEST ISSUE)

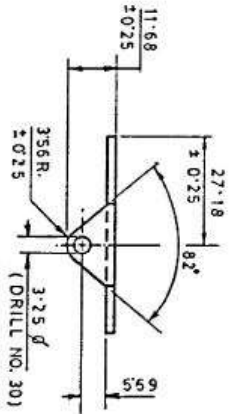

HEAT TREATMENT :-
CASE HARDENED TO A
DEPTH OF 0.20 AT 600-750 HV.

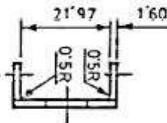
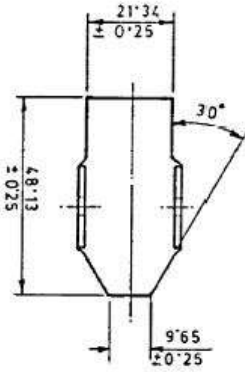

METRIC

17-03-81	PROFORMA CHANGED TO NOTE AND PROTECTIVE FINISH AMENDED, NEGATIVE TRACED & DRG. RE-SEALED.	APPROVED	DATE	AUTHY.
	PREVIOUS D.C. NOS. 1193-54, 15434-5A, 17707-5A, 17731-5A	DATE	SCALE	CHD.
	BRIEF RECORD	TRD. 24/83	1:1	EST. MASS:-
		DT. 31.10.83		DT. 10.12.89
				APPROVED
				(NEG. RE-TRACED)
DT. 17-03-83	MATERIAL: BS 1449 P11:1972 Gr. CR 34/20 SEC.3			
	OR D.D. QUALITY SHT. IS 513/83.			
	HARDNESS:- AS STATED			
	PROTECTIVE PHOSPHATE TO SPECN. JSS Q465-01:1994			
	FINISH: CLASS III (ACCELERATED) OIL FINISH.			
	ABBREVIATURE: PLATE OPERATING			
	DEFLECTOR CASE			
	D.S. CAT. NO. 1005-000664			

999000-5001

FOR EXPLANATION OF SYMBOLS REFER TO THE STANDARD DRAWING SYMBOLS AND TOLERANCES

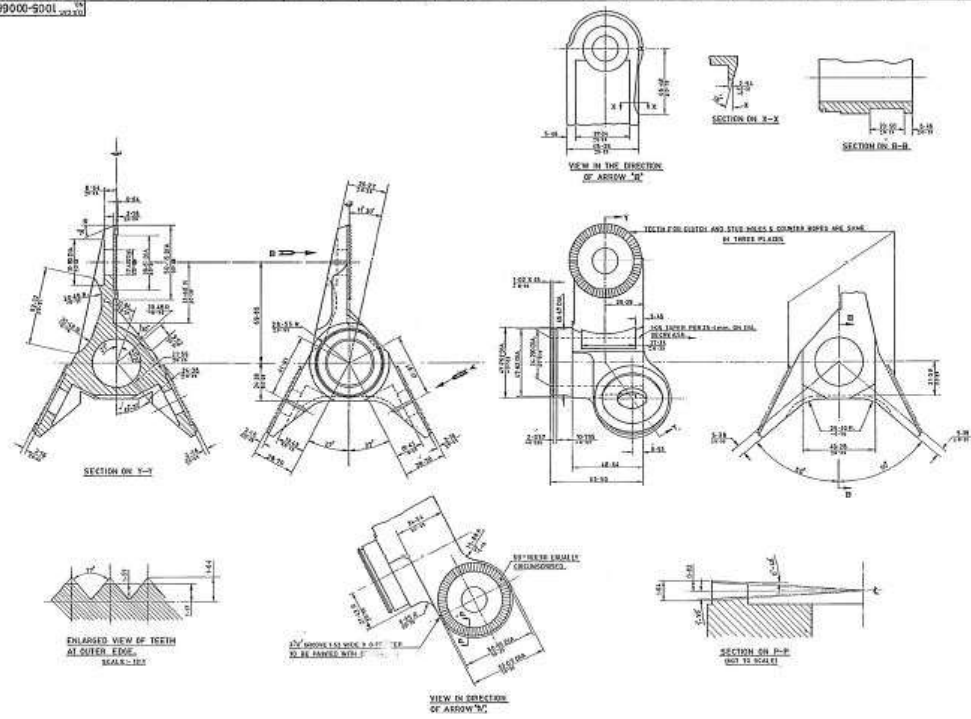

METRIC

DATE	1978	DESIGNER	...	APPROVED	...	GROUP	...
PROJECT	HOUSING PIVOT	CLASS.	...	PROJECT	...	CLASS.	...
NO.	...	REV.	...	NO.	...	REV.	...

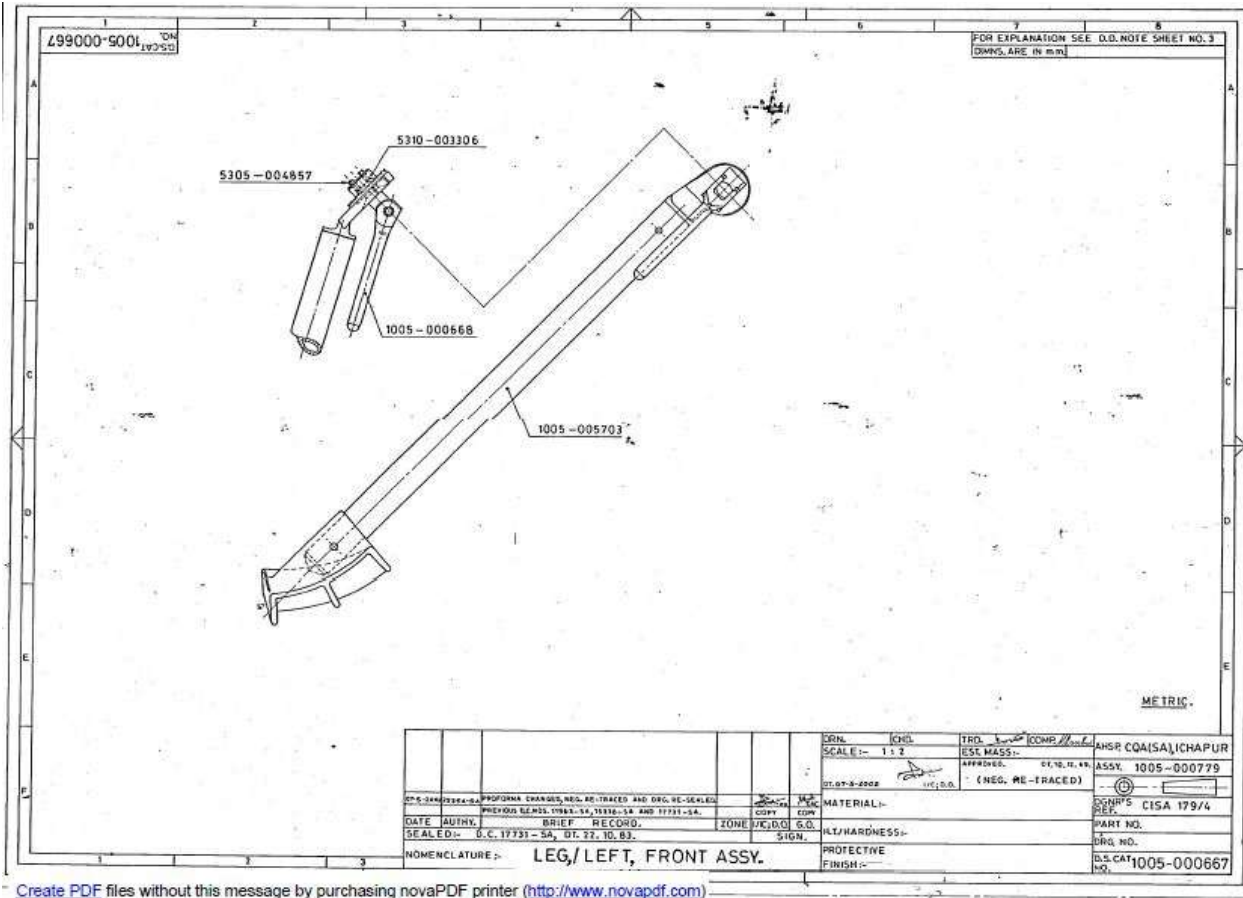

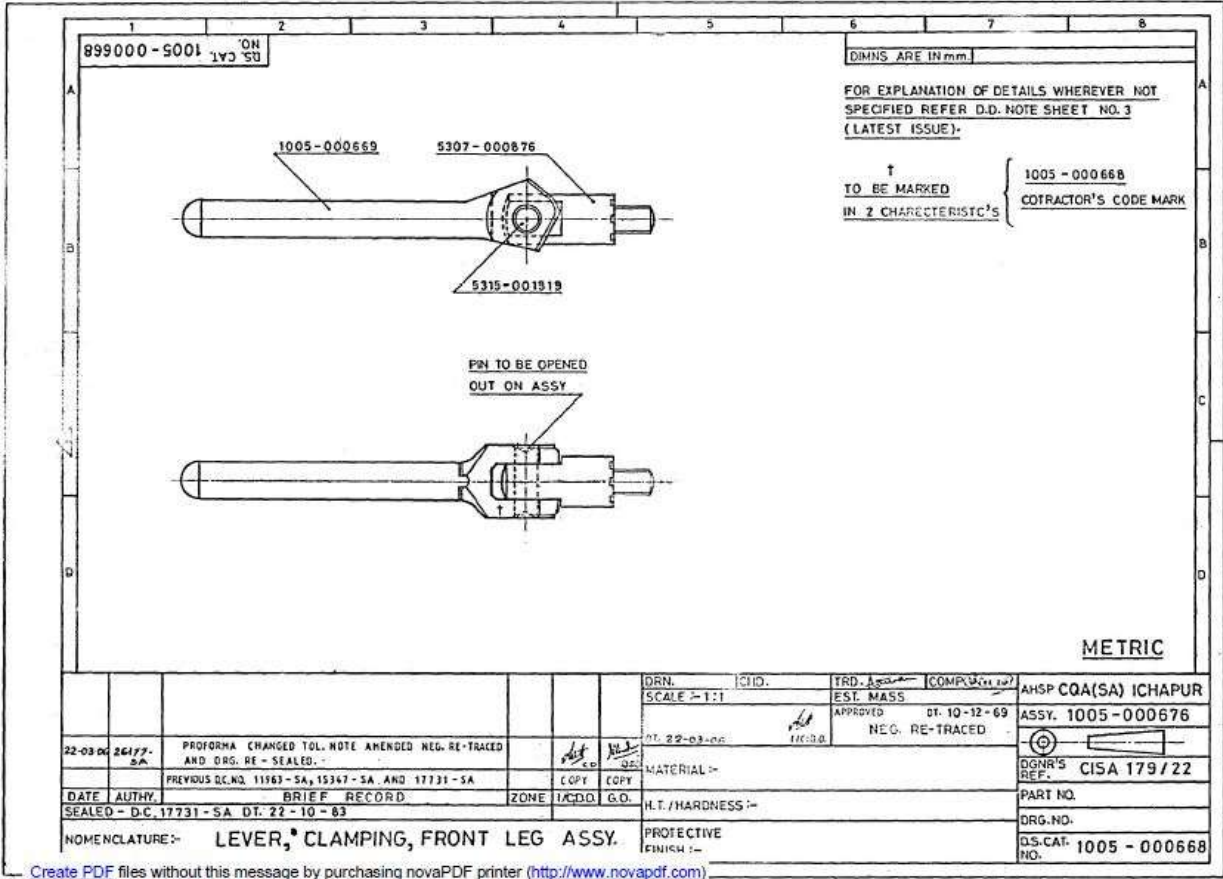

RS. CAT. 1005-000668
 ON NO.

DIMNS ARE IN mm.

FOR EXPLANATION OF DETAILS WHEREVER NOT SPECIFIED REFER D.D. NOTE SHEET NO. 3 (LATEST ISSUE).

↑
 TO BE MARKED IN 2 CHARACTERISTIC'S { 1005-000668 CONTRACTOR'S CODE MARK

METRIC

22-03-06		26177-5A	PROFORMA CHANGED TOL. NOTE AMENDED NEG. RE-TRACED AND DRG. RE-SEALED.	DRN.	SCALE :- 1:1	TRD. A	EST. MASS	COMP. (2/1/20)	AHSP CQA(SA) ICHAPUR
DATE AUTHY.		BRIEF RECORD		DT. 22-03-06	116-0.0	APPROVED	DT. 10-12-69	NEG. RE-TRACED	ASSY. 1005-000676
SEALD - D.C. 17731 - SA DT. 22-10-63		ZONE		COPY	COPY	MATERIAL :-		DGNR'S REF. CISA 179 / 22	
NOMENCLATURE :- LEVER, CLAMPING, FRONT LEG ASSY.				H.T. / HARDNESS :-		PROTECTIVE FINISH :-		PART NO.	
								DRG. NO.	
								D.S. CAT. NO. 1005-000668	

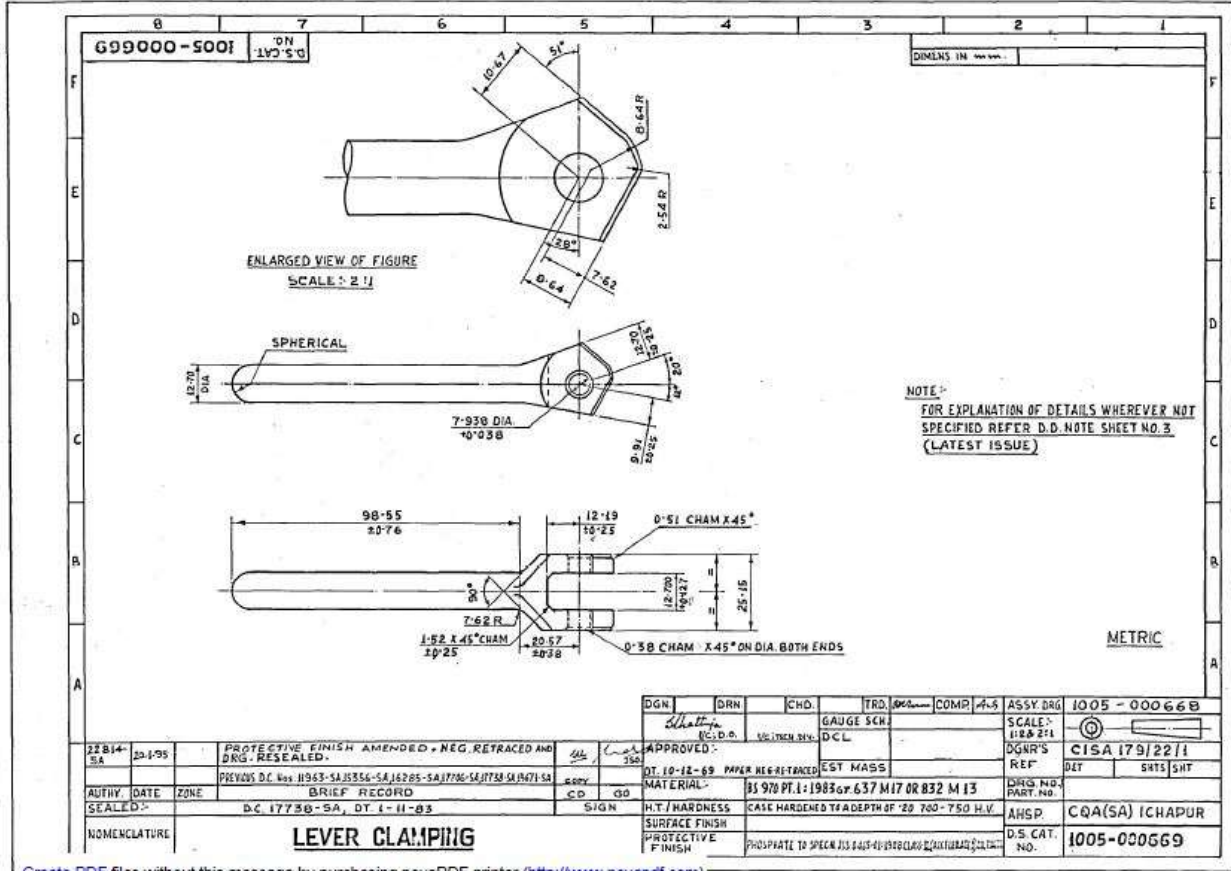

DGN		DRN	CHD.	TRD.	DATE	COMP.	REV.	ASSY. DRG.	1005-00066B
22814-5A		20-1-95						SCALE: 1:2.5	
PROTECTIVE FINISH AMENDED + NEG. RETRACED AND DRG. RESEALED.								DRAWN'S REF	CISA 179/22/1
PREVIOUS D.C. Nos. 11943-SAJ3356-SAJ6285-SAJ7790-SAJ7738-SAJ7154								DET	SATS/SHT
BRIEF RECORD								DRG. NO. PART NO.	
D.C. 17738-5A, DT. 1-11-83								AHSP.	CQA(SA) ICHAPUR
NOMENCLATURE		LEVER CLAMPING			H.T./HARDNESS		CASE HARDENED TO DEPTH OF 20-700-750 H.V.		D.S. CAT. No.
					SURFACE FINISH		PHOSPHATE TO SPEC. JIS S414-1983 (CLASS 2) (NITRIDING)		1005-000669
					PROTECTIVE FINISH				

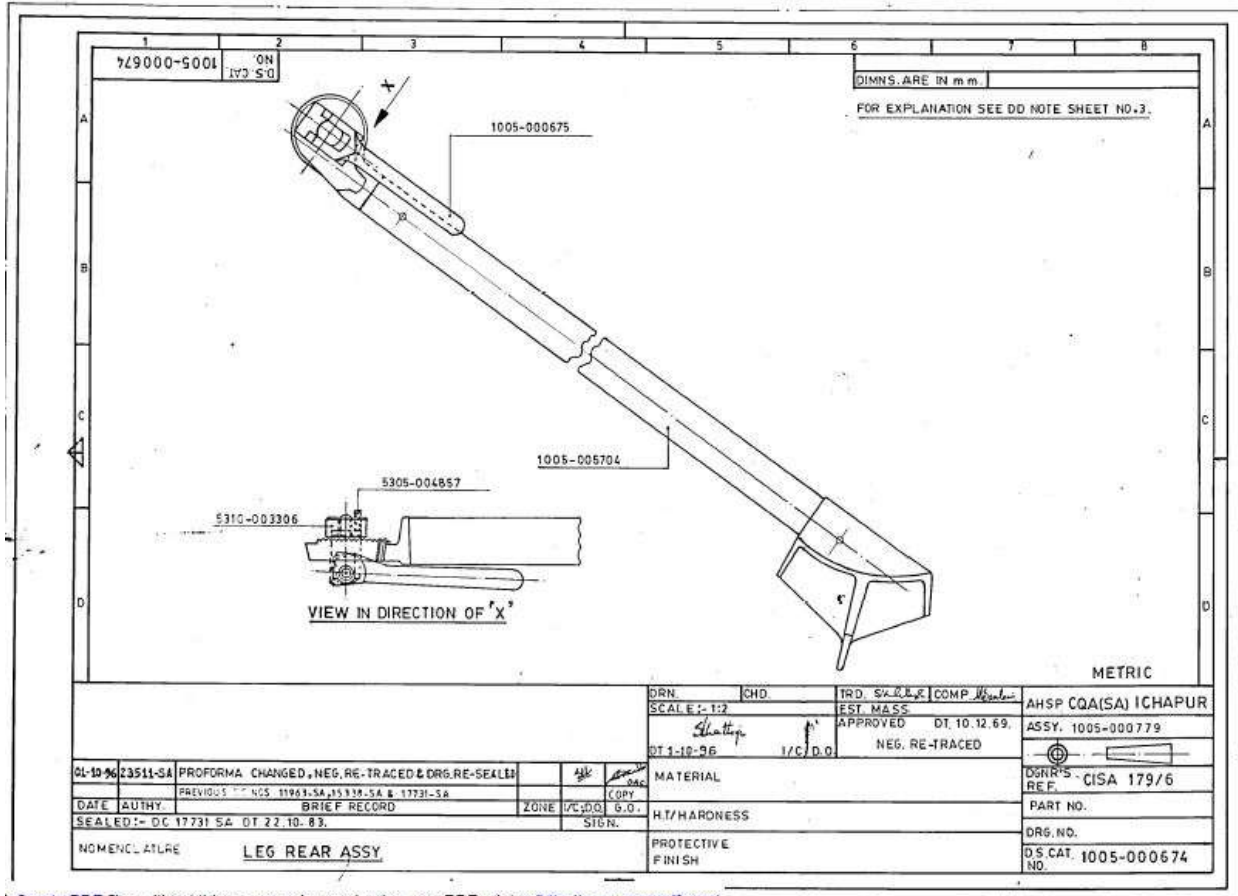

DRN.		CHD	TRD	SCALE	COMP	APPROVED	AHSP CQA(SA) ICHAPUR
SCALE: 1:2						EST. MASS	ASSY. 1005-000779
DT 1-12-96		1/C/D.O.				DT. 10.12.89	
NEG. RE-TRACED							
01-10-96	23511-SA	PROFORMA CHANGED, NEG. RE-TRACED & DRG. RE-SEALED					DGR'S REF. CISA 179/6
DATE AUTHY.	PREVIOUS NOS 11961-SA, 15138-SA & 17731-SA						
	BRIEF RECORD	ZONE	1/C/D.O.	G.O.			PART NO.
SEALED:-	DC 17731 SA DT 22.10.83.		SIGN.				DRG. NO.
NOMENCLATURE	LEG REAR ASSY						D.S. CAT. NO. 1005-000674

549000-5001

ON DIMS. ARE IN mm.

FOR EXPLANATION OF DETAILS WHEREVER NOT SPECIFIED, REFER DD NOTE SHEET NO. 3. (LATEST ISSUE)

TO BE MARKED IN 2 CHARACTERS { 1005-000675 CONTRACTORS CODE MARK

M. Madhoo
(S. C. Madhoo)
Dy. Asst. Controller
COA (SA) Mysore

5307-000876

1005-005705

5315-001549

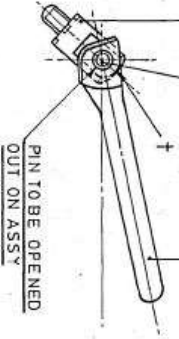

23.03.06 26178- PROFORMA CHANGED-TO-NOTE AMENDED-NEG-RE-TRACED
SA AND DRG. RE-FILED. PREVIOUS DC.NOS. 11893-SA, 13346-SA AND 17731-SA.

DATE AUTHY. BRIEF RECORD ZONE I/C: D.O. G.O. SIGN. COPY COPY

SEAL ED:- D.C. NO. 17731-SADT. 22.10.83. TRD. MR. [COMP. Sd/-] AHSR CQA(SA) CHAPUR

SCALE:- 1:2 EST. MASS:- DT. 10.12.89 APPROVED (NEG. RE-TRACED) ASSY. 1005-000674

DI. 23-03-06 I/C: D.O. MATERIAL:- DGNR'S CISA-179/24



H.T./HARDNESS:- PART NO. PROTECTIVE DRG. NO.

FINISH:- NOMENCLATURE:- LEVER, CLAMPING, REAR LEG, ASSY. D.S.CAT. NO. 1005-000675

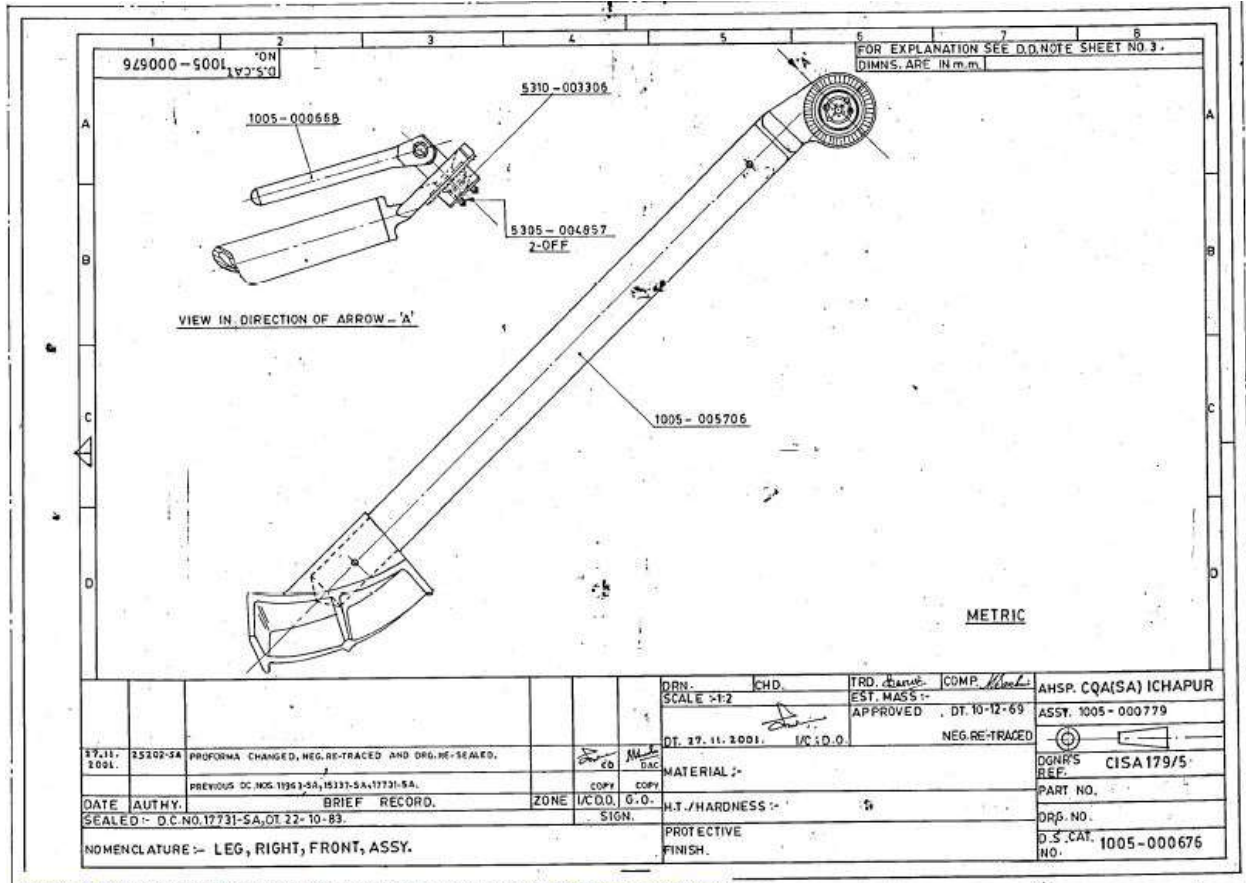
SCALE

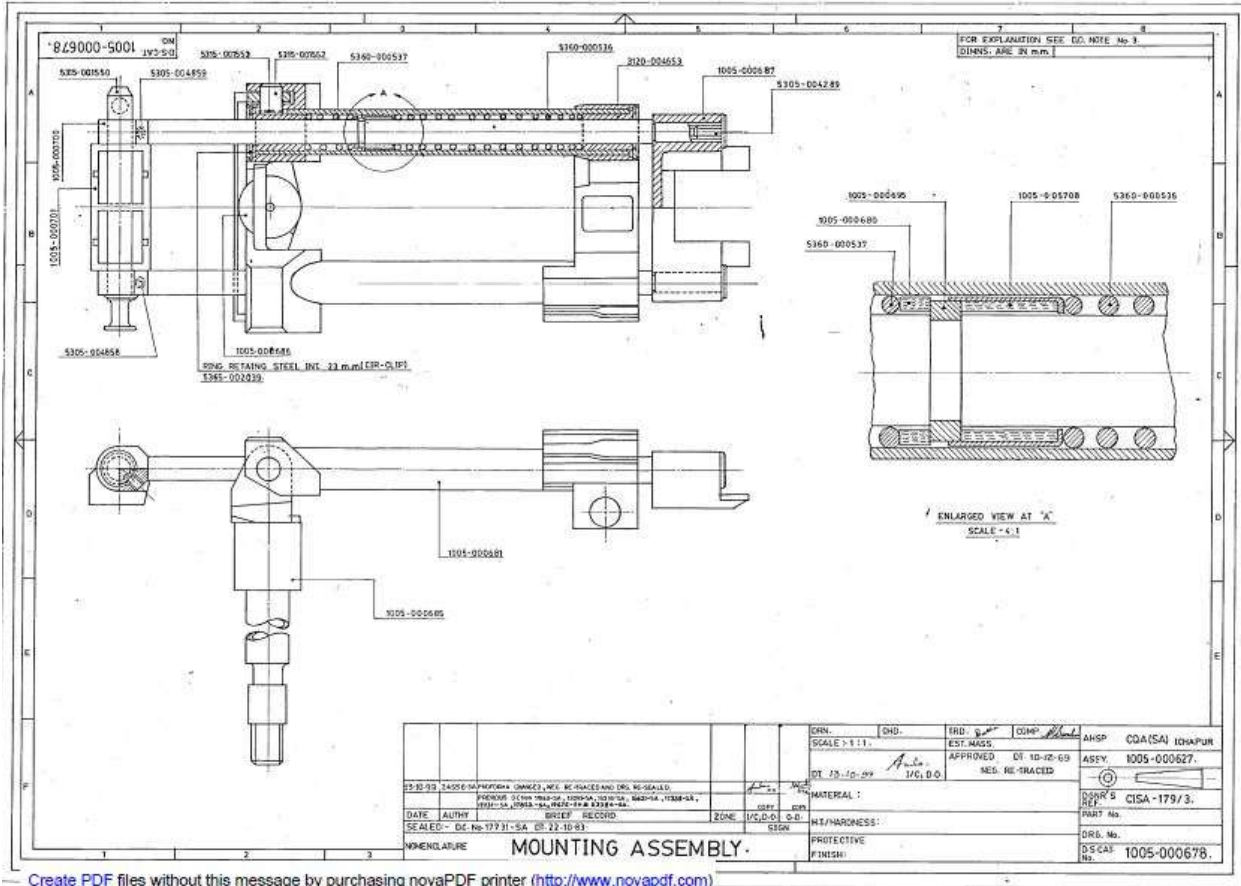

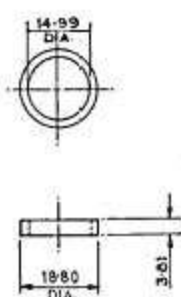

1	2	3	4
089000-5001		DRAWING CONVENTIONS CONFORM TO JSG-0104 DIMNS ARE IN mm.	
A			A
B			B
<p>ALT. MATERIAL</p> <p>ACRYLONITRILE BUTADIENE RUBBER COMPOUNDS TO SPECN. IND/ME/914 (PROV)</p> <p>NOTE</p> <p>FOR EXPLANATION OF DETAILS WHEREVER NOT SPECIFIED REFER D.D. NOTE SHEET NO. 3 (LATEST ISSUE)</p> <p style="text-align: right;">METRIC</p>			
C			C
12-3-95 22902-SA		NEG. RETRACED & DRG. RE-SEALED.	
SEALD. O.C. NO. 17734-SA DT. 1610-85		SIGN.	
PREVIOUS D.D. NOS. 1563-SA, 16376-SA, 15716-SA, 16282-SA, 17230-SA, 19158-SA, 20645-SA & 17387-SA		COPY	
DATA	AUTHY	BREF	RECORD
DRN	CHO	TRD	COMP
SCALE: 1:1	EST. MASS. 0.25 GRAM	ASSY.	1005-000678 1005-006863
MFG/INSP INSTRUCTIONS			
APPROVED: DT. 10-12-88 NEG. RE-TRACED.			
MATERIAL	VULCANISED BUTADIENE/ACRYLONITRIL RUBBER TO SPECN. BS. 2751:1976 BA-58.	AHSP	CQA(SA), ICHAPUR
HT./HARDNESS.		DGNR'S F.E.F.	CISA 179/50
PROTECTIVE FINISH.		PART NO.	
NOMENCLATURE	BUFFER RUNOUT	DRG. NO.	
		DS. CAT. NO.	1005-000680
1	2	3	4

Create PDF files without this message by purchasing no-va PDF printer (http://www.no-va.pdf.com/)

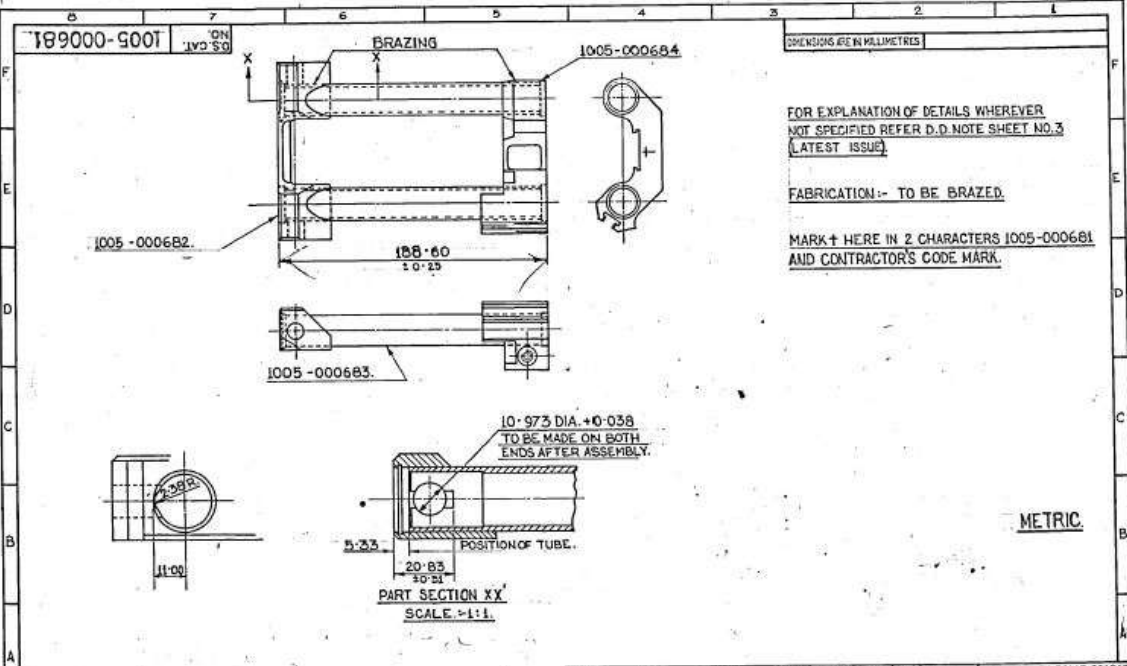

DGN.	DRN	CHD.	TRD.	10	20	COMP	4-3	ASSY.	1005-000678 & 1005-000683
								SCALE	1:2
								DGNR'S	CISA 179/25
								REF.	DET. 4-SHTS SHT. 1.
								DRG. NO./	
								PART. NO.	
								AHSP	CQA(SA)CHAPUR.
								D.S.CAT.	1005-000681.
								NO.	

17BIT- 20.3.95
 NEG. RE-TRACED AND DRG. RE-SEALED.
 PREVIOUS I.C. NOS. (1965-5A, 0352-5A, 0277-5A, 0754-5A, 2043-5A, 22535-5A)
 AUTHY. DATE ZONE BRIEF RECORD CD GO. MATERIAL. H.T./HARDNESS. SURFACE FINISH. PROTECTIVE FINISH.
 SEAL ED:- D.C.(Q) 17754-5A, DT. 26.10.83. SIGN. PHOSPHATE TO SPECN. JSS. 0445-01-1520 CLASS II (ACCELERATED) OIL FINISH.
 NOMENCLATURE **CARRIER RE-COIL**

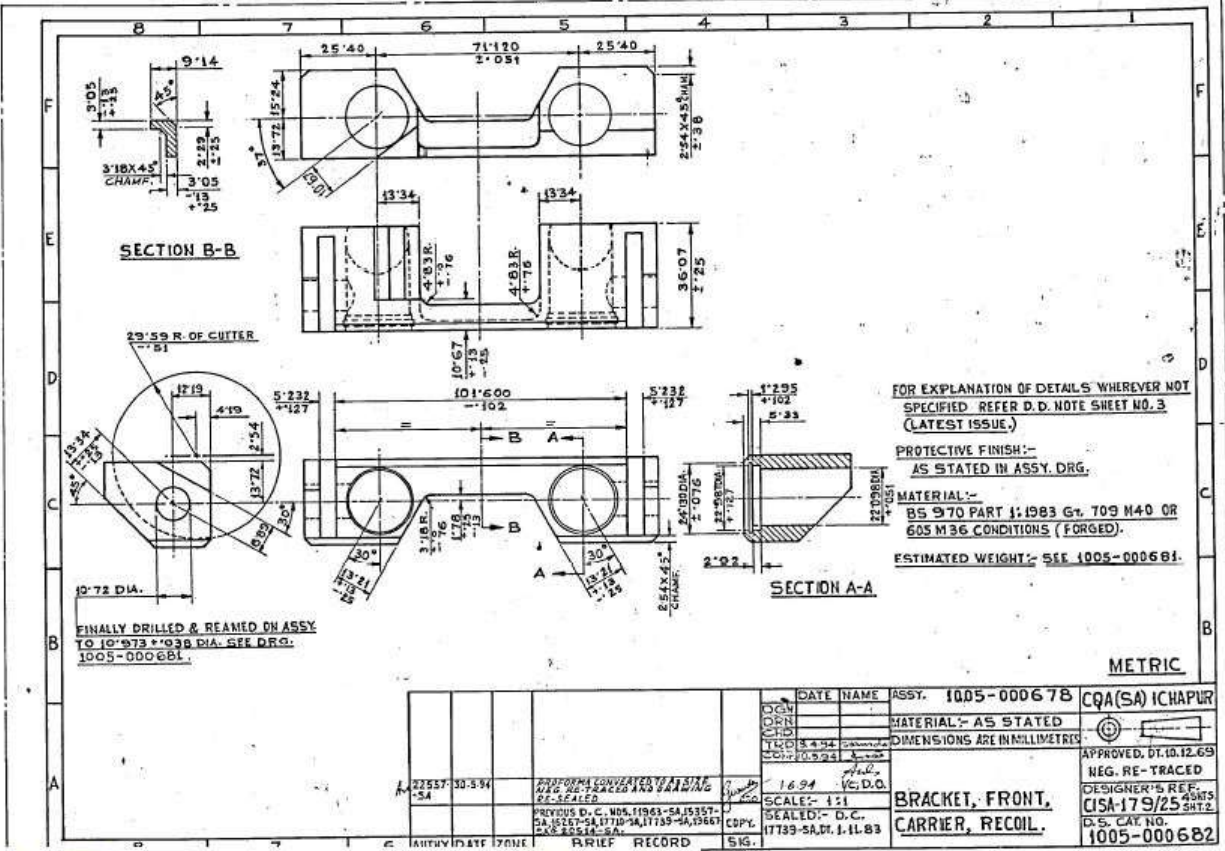

899000-5001 105-000683 DIMENSIONS ARE IN mm.

FOR EXPLANATION OF DETAILS
WHEREVER NOT SPECIFIED REFER
D.D. NOTE SHEET NO.3 (LATEST ISSUE)
NOTE:- SMOOTH M/C FINISH WHERE
MARKED

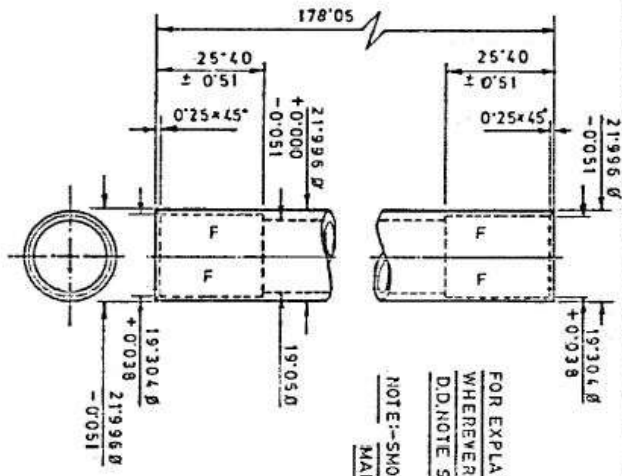

24-03-06	26179	PROFORMA CHANGED TO L. NOTE AMENDED, NEG RE-TRACED AND DRG. RE-SEALED.					
		PREVIOUS D.C. NOS. 17863-5A, 18335-5A, 18312-5A, 18283-5A, 17712-5A, 17773-5A, 17816-5A AND 18511-5A					
DATE	AUTHY	BRIF F RECORD	ZONE	I/C:DD	G.O.		
SEALED:—	D.C. NO. 17739-SADT. 1.11.83.						
DRN.	CHN.	TRD.	CONR.	APPROVED	DI:101269		
SCALE:—							
DT. 24-03-06							
MATERIAL:—	BS 6323 Pt. 4: 1982 CFS 3 BK.						
H./HARDNESS:—							
PROTECTIVE FINISH:—	AS STATED IN ASSY DRG.						
NOMENCLATURE:—	TUBE RECOIL						

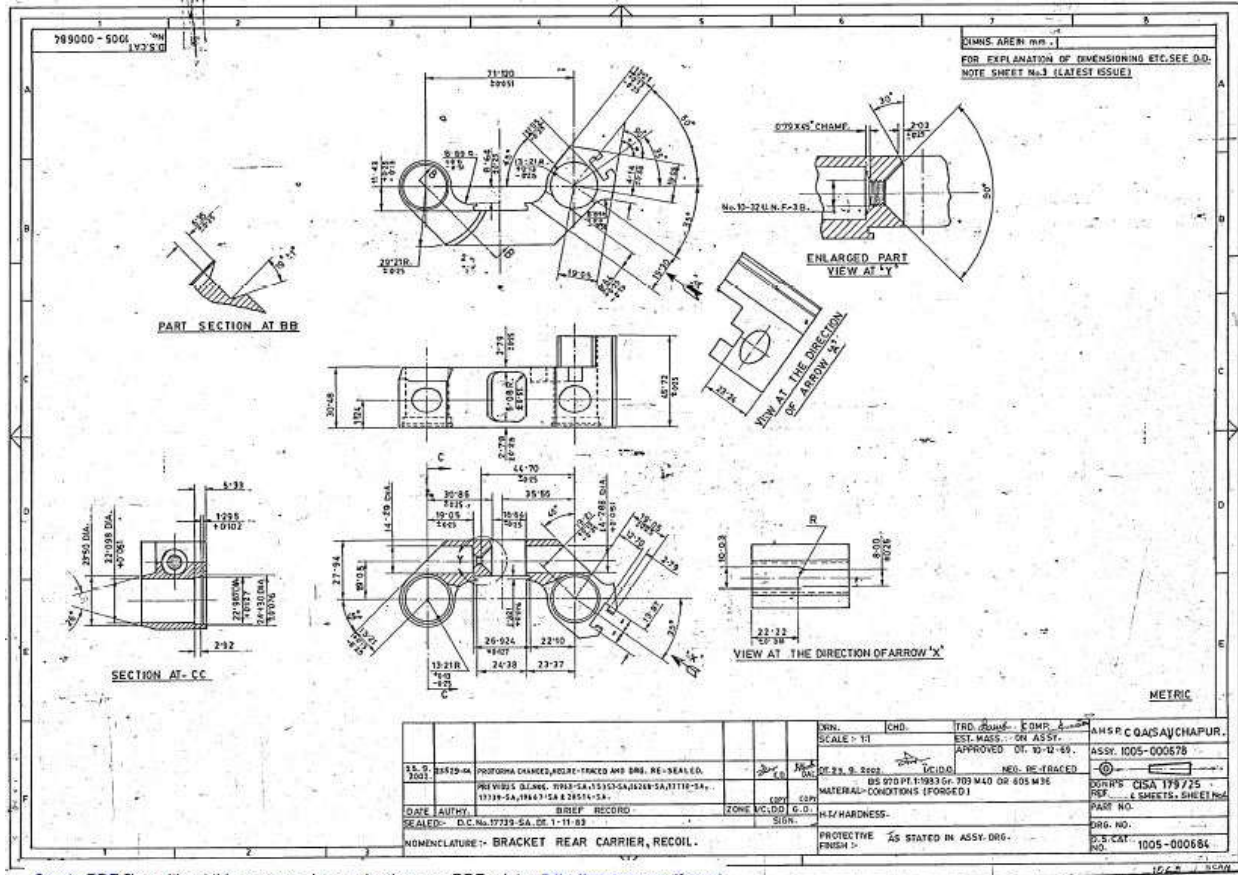

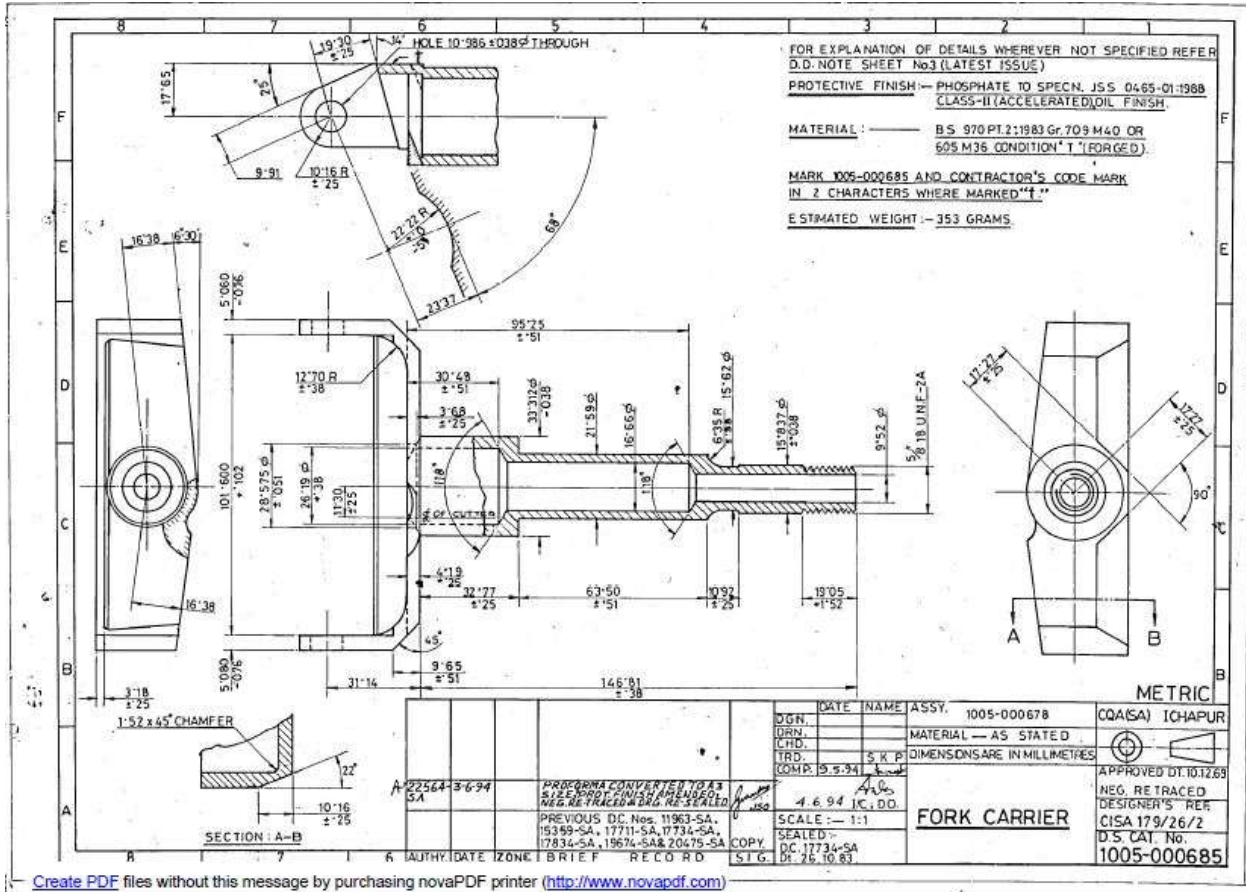

989000-5001
 DIMS. ARE IN MM.

FOR EXPLANATION OF DETAILS WHEREVER NOT SPECIFIED, REFER DD. NOTE SHEET NO. 3 (LATEST ISSUE)

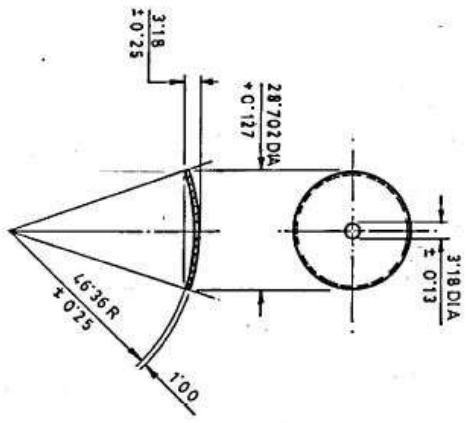

27-5-06		PROFORMA CHANGED TO NOTE AND PROTECTIVE FINISH AMENDED, NEG. TRACED & DRG. RE-SEALED.		C.D. COPY	
DATE	AUTHY.	BRIEF RECORD	ZONE	U/C/D.O.	G.O.
SEALD	DC/NO. 17734-SA DT. 26.10.83.	TRD. & EST. MASS. 5 GRAMS	AHSP CQA(SA) CHAPUR	ASSY.	1005-000678 & 1005-000686
SCALE	1:1	APPROVED	DI: 10.12.89	U/C/D.O.	G.O.
DI. 27-5-06	MATERIAL: D.D. QUALITY SH. 15-513/63	U/C/D.O.	(NEG. RE-TRACED)	SIGN.	
H.T/HARDNESS	PHOSPHATE TO SPECN. JSS 0465-01:1994	FINISH	CLASS II (ACCELERATED), OIL FINISH.	PART NO.	CISA-179/26/1
NOMENCLATURE	DISC FORK	D.S. CAT. NO.	1005-000686		

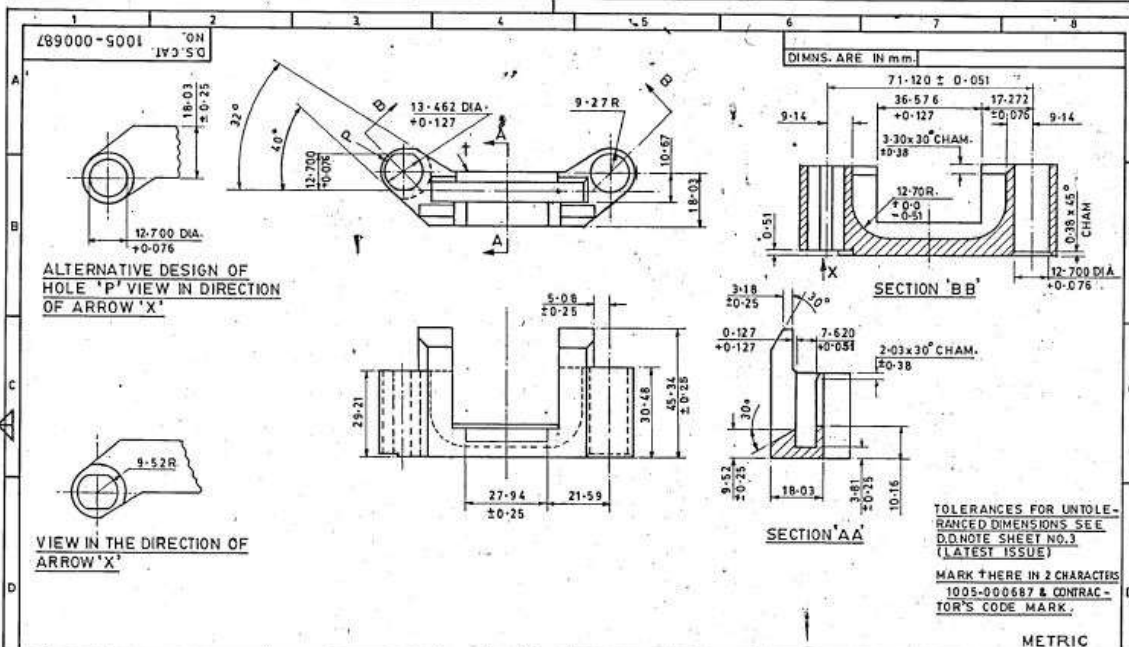

DRN.		CHD.	TRD. <i>Sharma</i>	COMP. <i>M. S. Reddy</i>	AH SP CQA(SA) ICHAPUR
SCALE:- 1:1			EST. MASS:- 200 GRAMS	APPROVED DT. 10.12.69	ASSY. 1005-000 678
198-99	24463-SA	PROGRAM CHANGED & REDUCED, PROTECTIVE FINISH AMENDED, NEG. RE-TRACED AND D.D. RE-SEALED.	DT 12-8-99	NEG. RE-TRACED	
DATE AUTHY.		BRIEF RECORD	ZONE I/C/D/O	G.O.	DGNR'S REF. CISA 179/51
SEALD :- D.C. NO. 17734-SA, DT. 26.10.83			H.T./HARDNESS :-		PART NO.
NOMENCLATURE :- MOUNTING REAR			PROTECTIVE FINISH :-	PHOSPHATE TO SPECN. JSS:0465-01:1988 CLASS II (ACCELERATED) OIL FINISH.	DRG. NO.
					D.S. CAT. NO. 1005-000687

969000-5001		FOR EXPLANATION SEE D.D. NOTE SHEET NO. 3.	
ON 1975 Q		DIMMS. ARE IN mm.	
<p>WHERE TOLERANCES ARE NOT SHOWN DIMMS. IN WHOLE NUMBER OR WITH ONE DECIMAL PLACE ± 1.27mm. DIMMS. WITH TWO DECIMAL PLACES ± 0.13mm.</p>			
METRIC			
PROFORMA CHANGED, PROTECTIVE FINISH AMENDED, NEG. RE-TRACED AND DRG. RE-SEALED. PREVIOUS D.C. NOS: 1933-SA, 1334-SA, 17734-SA, 18238-SA, 1937-SA, AND 2213-SA			
DATE	AUTHY.	TRD.	COMP.
23-7-2003	25813-SA	18238-SA	1937-SA
SEALING: - DCNO17739-SA D.I.1.1.83.			
BRIEF RECORD			
DRN.	CHD.	TRD.	COMP.
DI. 23-7-2003	1937-SA	18238-SA	1937-SA
EST. MASS: - 2.5 GRAMS.			
APPROVED (NEG. RE-TRACED)			
MATERIAL: - B.S. 970 P.L. 1: 1983 G. 6: 070 M. 20. OR D.D.			
QUALITY SH. 15: 513-1986			
H.V. HARDNESS: -			
PHOSP. DATE TO SPECN: JS: 0.65: 01-1994			
FINISH: - CLASS: 1 (ACCELERATED), OIL FINISH			
NOMENCLATURE: - SPACER, SLEEVE.			
D.S. CAT. 1005-000696		PART NO.	
D.O.		DRG. NO.	

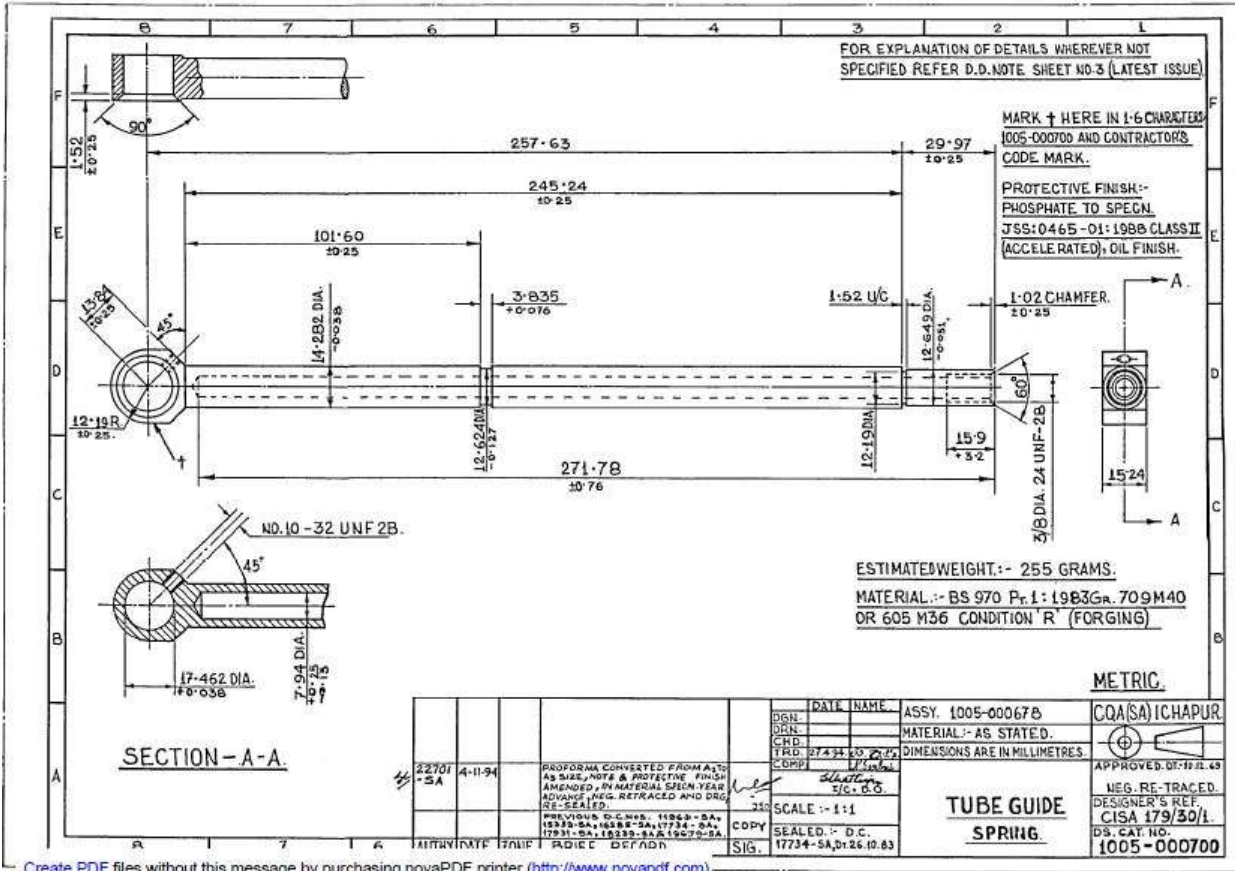

FOR EXPLANATION OF DETAILS WHEREVER NOT SPECIFIED REFER D.D.NOTE SHEET NO.3 (LATEST ISSUE)

MARK † HERE IN 1:6 CHARACTERS 1005-000700 AND CONTRACTOR'S CODE MARK.
 PROTECTIVE FINISH:- PHOSPHATE TO SPECN. JSS:0465-01:1988 CLASS II (ACCELERATED), OIL FINISH.

ESTIMATED WEIGHT:- 255 GRAMS.
 MATERIAL:- BS 970 Pr.1: 1983 Gr. 709M40 OR 605 M36 CONDITION 'R' (FORGING)

METRIC.

SECTION - A-A.

22701	4-11-94	PROFORMA CONVERTED FROM A TO AS SIZE, NOTE & PROTECTIVE FINISH AMENDED, IN MATERIAL SPEC YEAR ADVANCE (P.C. RETRACED AND DRG. RE-SEALED).
		PREVIOUS D.C.NOS. 11968-5A, 15339-5A, 16588-5A, 17734-5A, 17831-5A, 18239-5A & 19070-5A.

DATE	NAME	ASSY. 1005-000678
DRN.		MATERIAL:- AS STATED.
CRD.		DIMENSIONS ARE IN MILLIMETRES.
TRD.	27.4.94	
COMP.	17/10/63	
	S. C. D. C.	
COPY	SCALE 1:1	
	SEALED:- D.C.	
SIG.	17734-5A, 01.26.10.63	

TUBE GUIDE SPRING

CQA(SA) ICHAPUR
 APPROVED: 07-11-83
 NEG. RE-TRACED.
 DESIGNER'S REF. CISA 179/30/1.
 DS. CAT. NO. 1005-000700

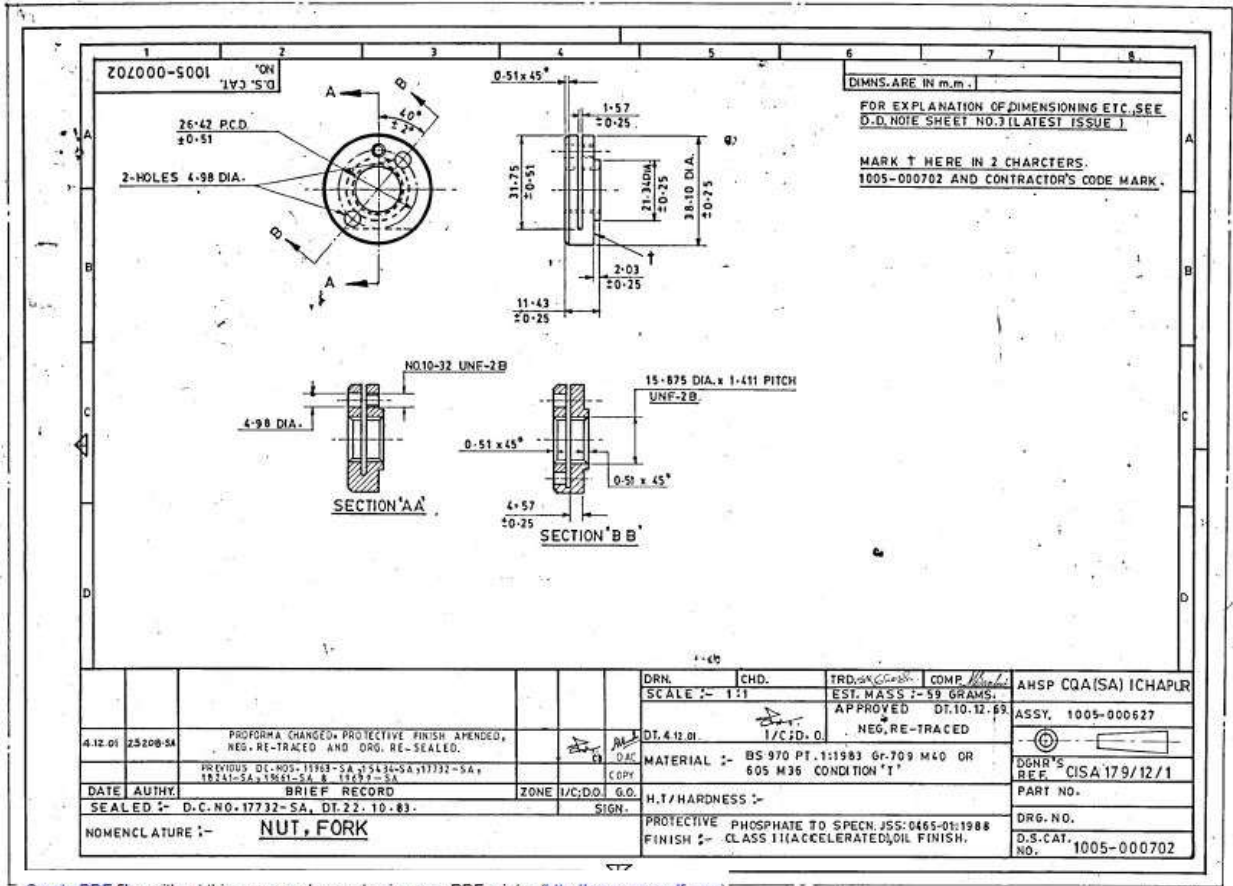

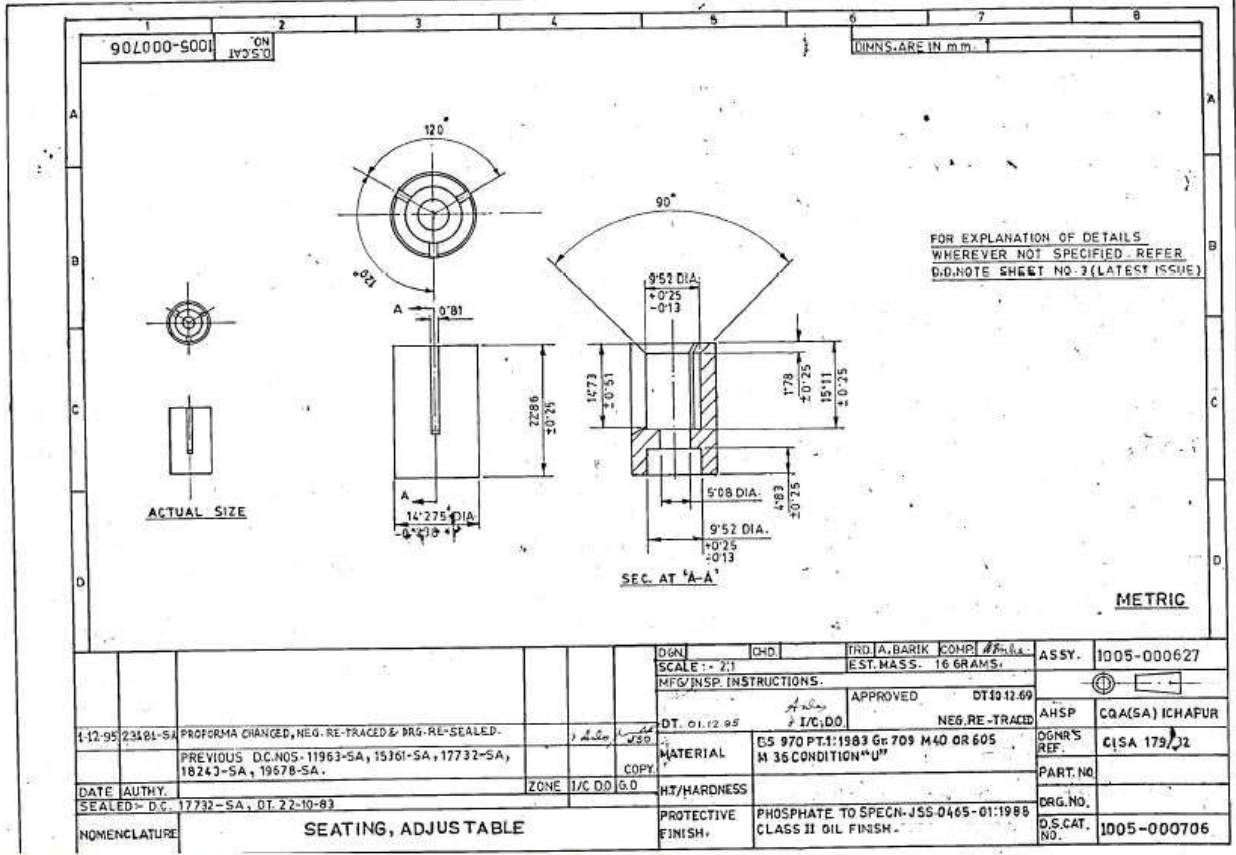

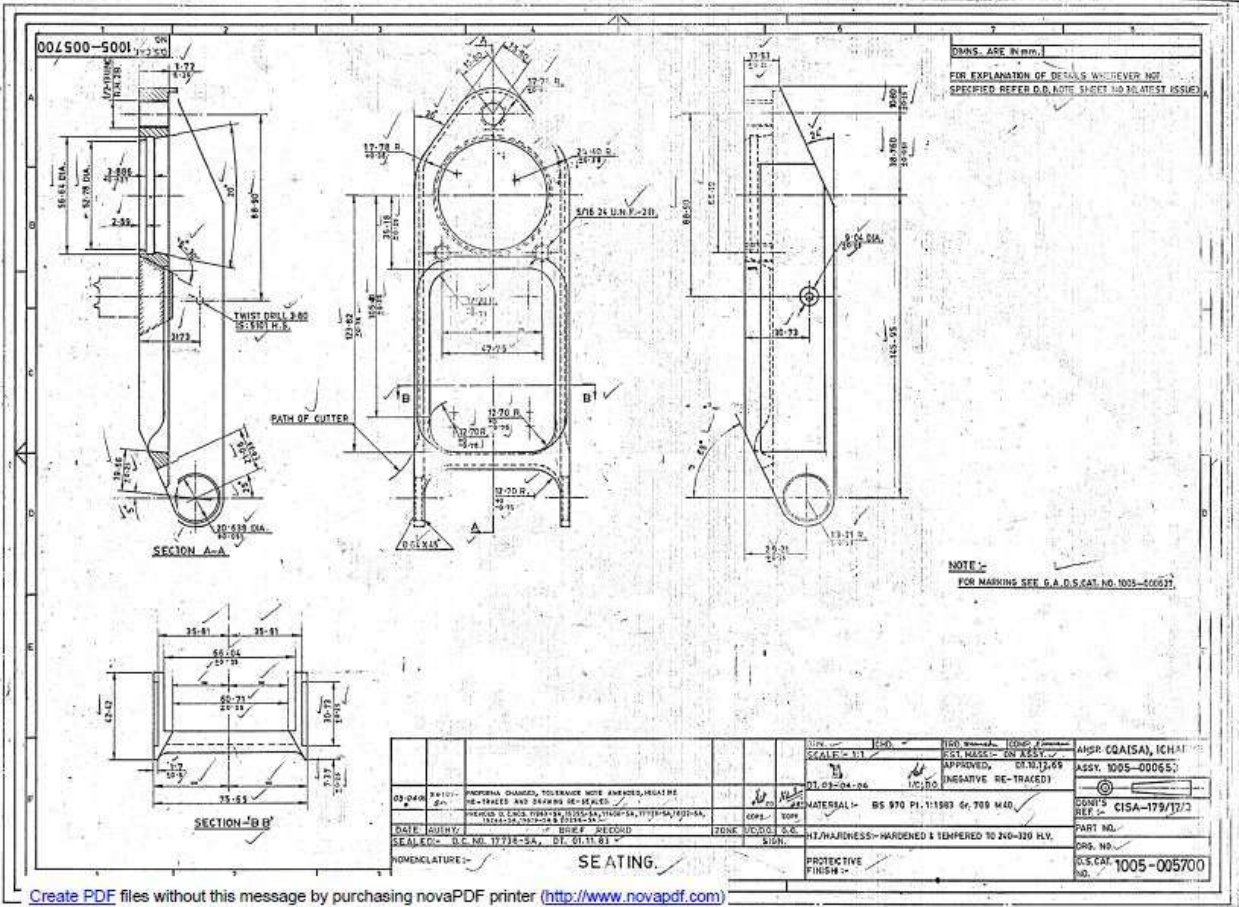

2 LMS 54MS 4
 001900-9001 2P 5

DIMENSIONS ARE IN mm.
 FOR EXPLANATION OF DIMENSIONING ETC SEE
 D.O. NOTE SHEET No. 3 (LATEST ISSUE)

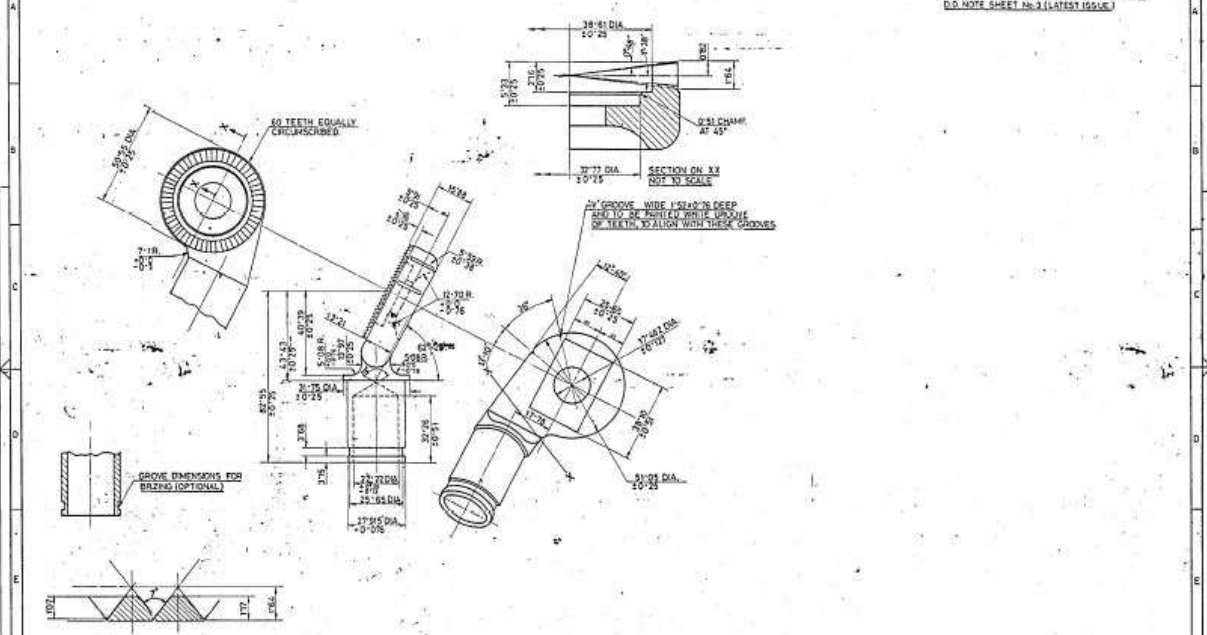

										METRIC		
QRM	QMD	TRD. S.X.P.	COMP.	ASHP	COA(SA)	ICHAPUR						
SCALE	1:1	EST. MASS	316 GRAMS	APPROVED	01.10.12.69	ASSY	1005-005703(SHT 1)					
DT. 16.10.1999	VC: D.O.	NEG. RE-TRACED										
MATERIAL	85 970 P11 1983 Qr 803 M17 QR 637 M17.											
HUMIDNESS	RIGHT OF LINE XX 650-750 KV TO A DEPTH OF 0.20mm											
PROTECTIVE FINISH	ON SHT. 1											
NON-SIGNATURE							JOINT, LEFT, LEG, FRONT					
DATE	AUTHY	DATE	RECORD	ZONE	QRM	QMD	QRM	QMD	QRM	QMD	PART No.	85 CAT 1005-005703
SEALED	D.E. No 1793-64, 01.10.12.61										5 SHTS: SHT 2	

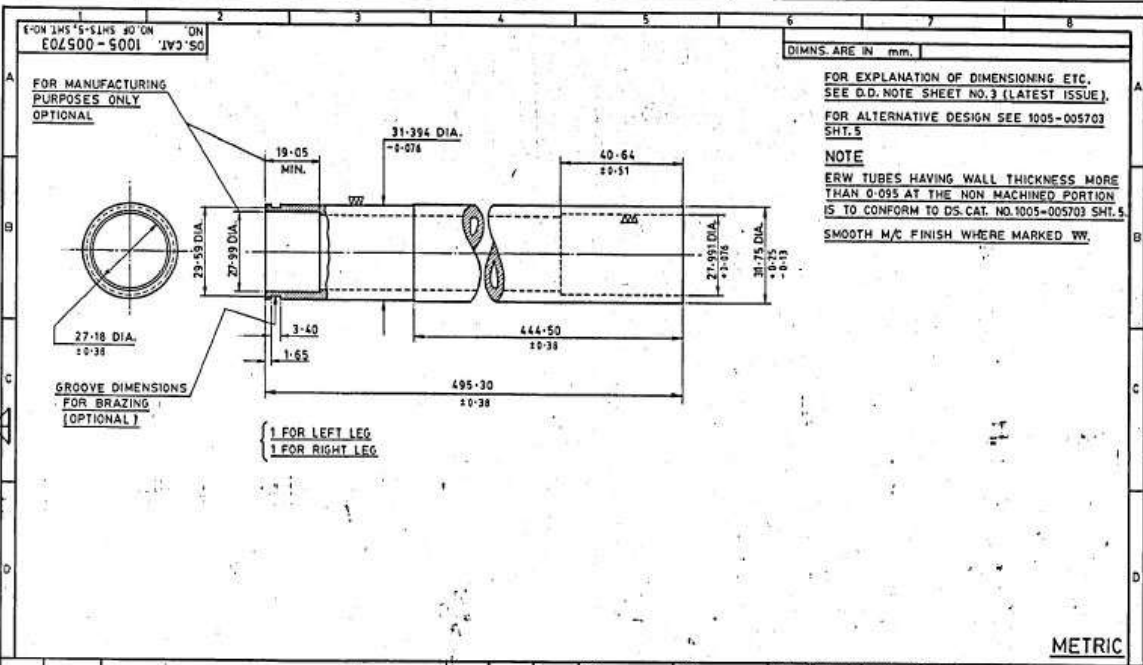

DIMNS. ARE IN mm.

FOR EXPLANATION OF DIMENSIONING ETC. SEE O.D. NOTE SHEET NO. 3 (LATEST ISSUE).
FOR ALTERNATIVE DESIGN SEE 1005-005703 SHT. 5

NOTE
ERW TUBES HAVING WALL THICKNESS MORE THAN 0.095 AT THE NON MACHINED PORTION IS TO CONFORM TO DS. CAT. NO. 1005-005703 SHT. 5.
SMOOTH M/C FINISH WHERE MARKED WW.

METRIC

DRN		CHD.	TRD. <i>Handwritten</i>	COMP. <i>Handwritten</i>	AHSP, CQA(SA), ICHAPUR
SCALE:- 1:1		EST. MASS:- 700 GRAMS			ASSY. 1005-005703, SHT-1 & 1005-005704, SHT-1
DT. 4-3-2000		APPROVED, DT. 10-12-69 (NEGATIVE RE-TRACED)			
4-3-2001 A4097-SA		PROFORMA CHANGED, M/C FINISH SYMBOL AMENDED, NEGATIVE			DGNR'S CISA 179/59
DATE AUTHY.		BRIEF RECORD			REF. NO OF SHTS-3, SHT NO-3
SEALED:- D.C. 17733-SA, DT. 26-10-83		ZONE	INC/DG.	G.O.	PART NO.
NOMENCLATURE: TUBE, LEG, FRONT.		PROTECTIVE FINISH:-			DRG. NO.
		INTERNAL SURFACE OF TUBE TO BE PHOSPHATE TO SPECN. ISS: 0465-01-1988 CLASS-II (ACCELERATED), OIL FINISH.			DS. CAT. 1005-005703 NO. NO OF SHTS-3, SHT NO-3.

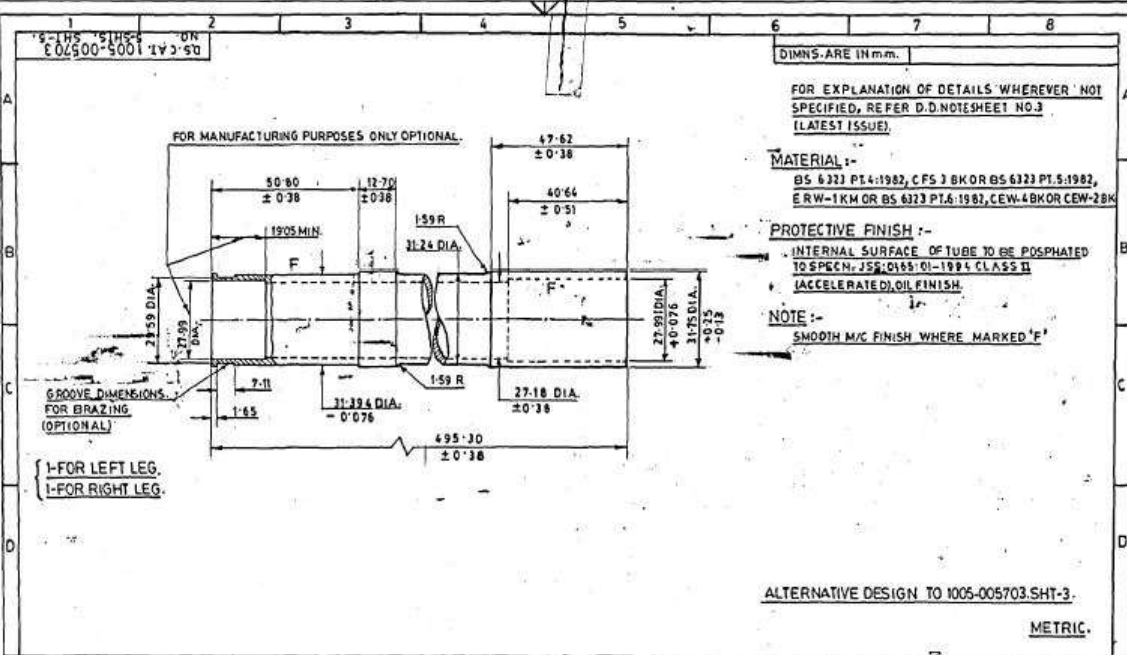

DRN.		I.C.H.D.		TRD.		COMP.		AHSPCQA(SA)CHAPUR.	
SCALE 1:1				EST. MASS 700 GRAMS				ASSY.	
DT. 01-11-02		1/C, 00		APPROVED. DT. 29.11.04				NEG. RE-TRACED.	
10573-3-11-02		PROPORNA CHANGED, TOL. NOTE AND PROTECTIVE FINISH AMENDED, NEG. RE-TRACED AND DNG. RE-SEALED.		MATERIAL :- AS STATED				DGNR'S CISA 179/59	
AUTHY. DATE		BRIEF RECORD		HI/HARDNESS :-				REF. 5 SHTS, SHT. 5	
SEALED :- D.C. NO. 17733-5A.DT. 29.10.03		ZONE		1/C, 00		G.O.		PART NO.	
NOMENCLATURE :- TUBE, LEG, FRONT.		S. 10.21		PROTECTIVE FINISH :- AS STATED				DRG. NO.	
								D.S.CAT. 1005-005703	
								NO 5 SHTS, SHT. 5.	

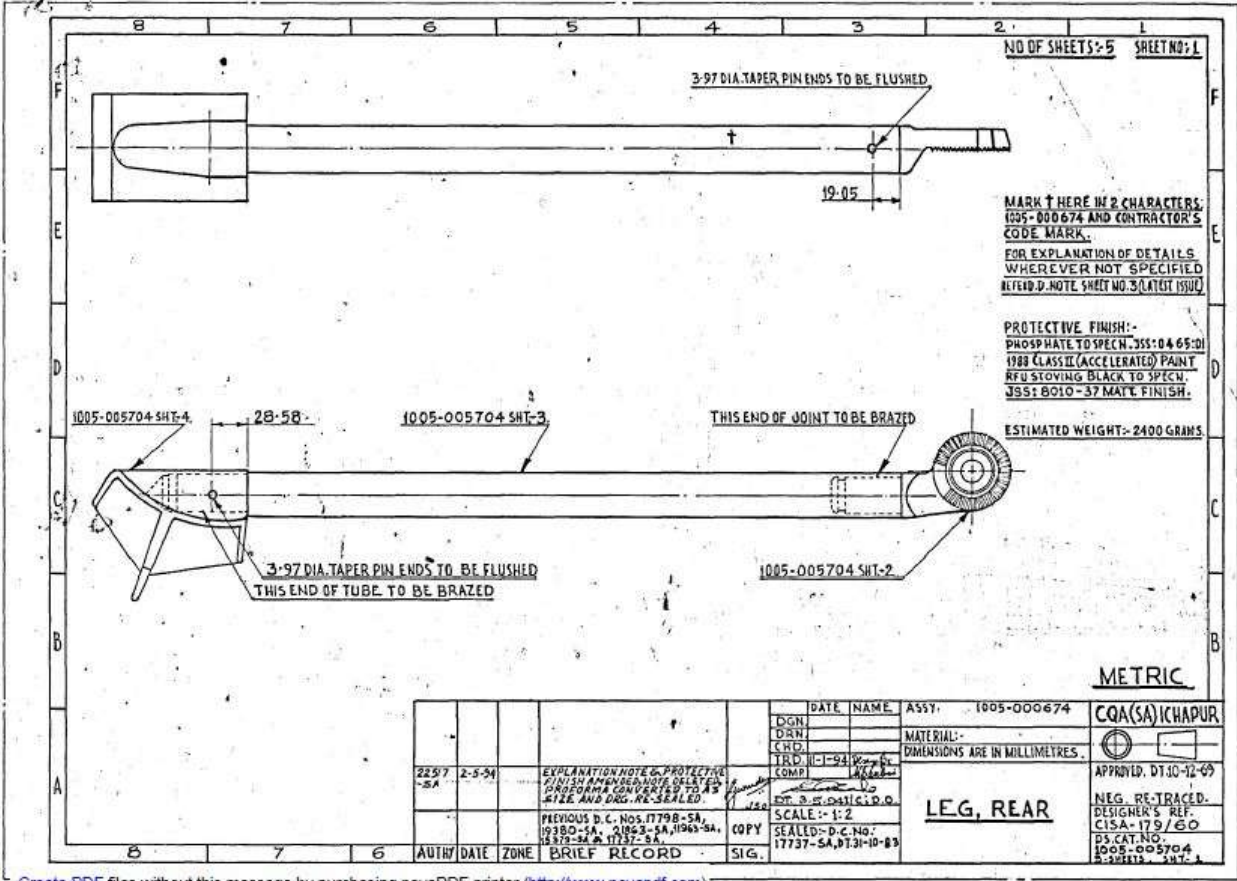

NO OF SHEETS: 5 SHEET NO: 1

MARK T HERE IN 2 CHARACTERS:
1005-000674 AND CONTRACTOR'S
CODE MARK.
FOR EXPLANATION OF DETAILS
WHEREVER NOT SPECIFIED
REFER D. NOTE SHEET NO. 3 (LATEST ISSUE)

PROTECTIVE FINISH:-
PHOSPHATE TO SPECN. JSS: 04 65:01
1988 CLASS II (ACCELERATED) PAINT
RFU STOVING BLACK TO SPECN.
JSS: 8010-37 MATL. FINISH.

ESTIMATED WEIGHT:- 2400 GRAMS

METRIC

		DATE	NAME	ASSY.	1005-000674	CQA(SA) ICHAPUR	
		DGN		MATERIAL:			APPROVD. DT: 10-12-69
		DRN		DIMENSIONS ARE IN MILLIMETRES.		NEG. RE-TRACED. DESIGNER'S REF. CISA- 179/60 DS CAT. NO. 1005-005704 5 SHEETS - 2/1-1	
		CHD			DATE		
2257 -SA		2-5-54			1-1-93		
			EXPLANATION NOTE G, PROTECTIVE FINISH APPROVED BY GSA. PROGRAM CONVERTED TO A3 #122 AND DWS-RE-SEALED.	COMP			
			PREVIOUS D.C. NOS. 17798-SA, 19380-SA, 21053-SA, 19649-SA, 25879-SA & 17737-SA.				
AUTH		DATE	ZONE	BRIEF RECORD	COPY		
					17737-SA, DT: 31-10-83		
				SIG.			

LEG, REAR

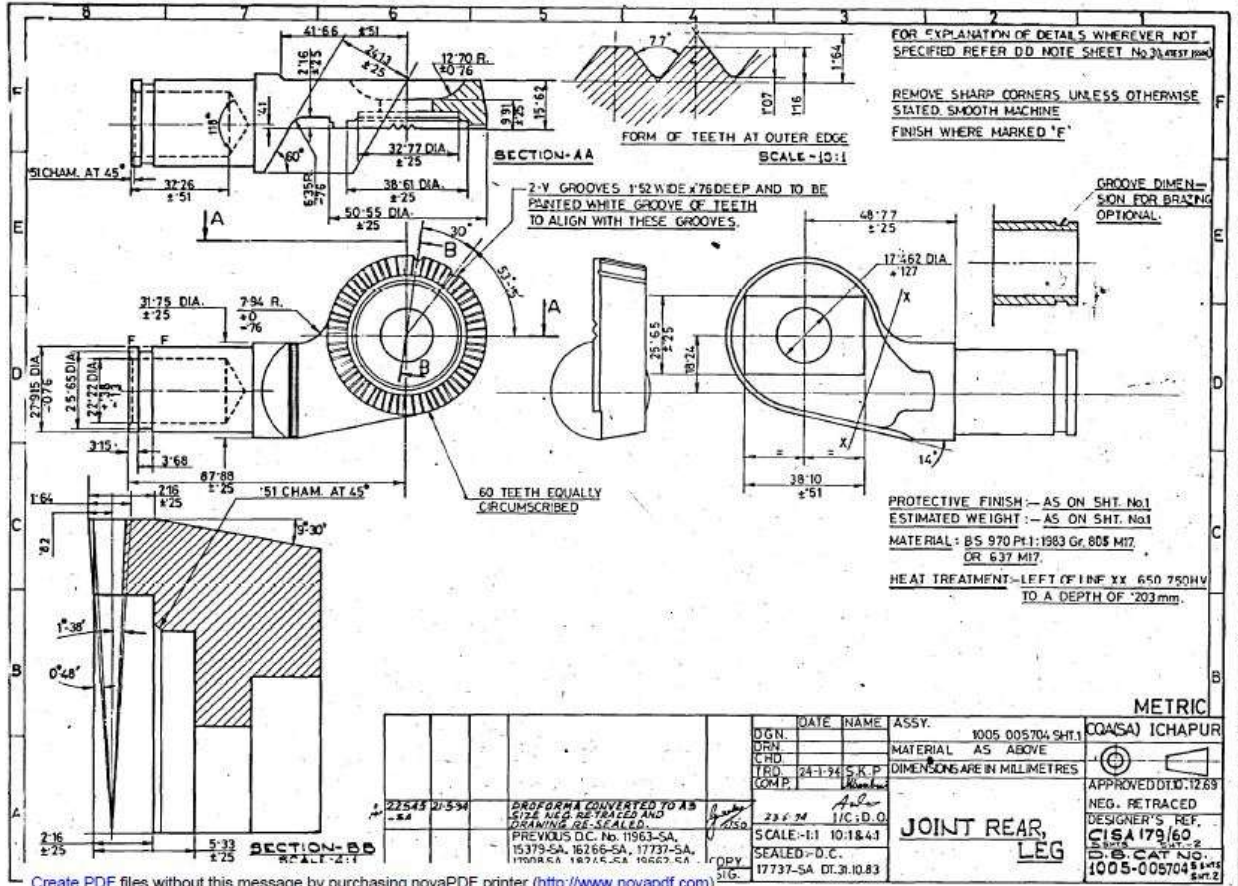

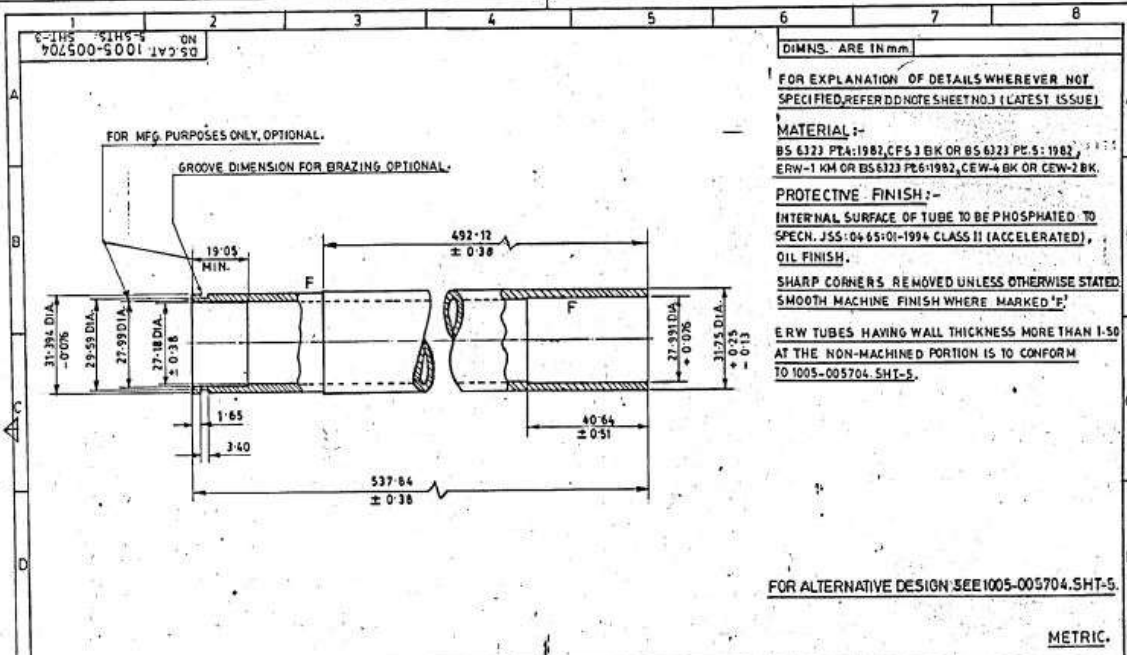

DIMNS. ARE IN mm

FOR EXPLANATION OF DETAILS WHEREVER NOT SPECIFIED, REFER DD NOTE SHEET NO.3 (LATEST ISSUE)

MATERIAL :-
 BS 6323 PTA:1982, CF5.3 BK OR BS 6323 PE.5:1982,
 ERW-1 KM OR BS 6323 PE.6:1982, CEW-4 BK OR CEW-2 BK.

PROTECTIVE FINISH :-
 INTERNAL SURFACE OF TUBE TO BE PHOSPHATED TO SPECN. JSS:04-65:01-1994 CLASS II (ACCELERATED), OIL FINISH.
 SHARP CORNERS REMOVED UNLESS OTHERWISE STATED.
 SMOOTH MACHINE FINISH WHERE MARKED 'F'

ERW TUBES HAVING WALL THICKNESS MORE THAN 1.50 AT THE NON-MACHINED PORTION IS TO CONFORM TO 1005-005704.SHT-5.

FOR ALTERNATIVE DESIGN SEE 1005-005704.SHT-5.

METRIC.

11.9.2002		25510-54	PROFORMA CHANGED, TOLNOTE AND PROTECTIVE FINISH AMENDED, NEG. RE-TRACED AND ORG. RE-SEALED.	CD	CD	DT. 11.9.2002	APPROVED. DT.10.12.69	ANSP. CQA(SA)CHAPUR.
DATE		AUTHY	BRIEF RECORD	ZONE	CD	CD	NEG. RE-TRACED.	ASSY. 1005-005704.SHT-1
SEALED:-		D.C. NO. 17737-SA, DT. 31.10.83		CD	CD	MATERIAL :- AS STATED		DGN'S REF. CISA 179/60
NOMENCLATURE :-		TUBE, REAR LEG.		CD	CD	HT./HARDNESS :-		PART NO.
				CD	CD	PROTECTIVE FINISH :- AS STATED		DRG NO.
				CD	CD			D.S. CAT. 1005-005704
				CD	CD			S-SWTS. SHT-1

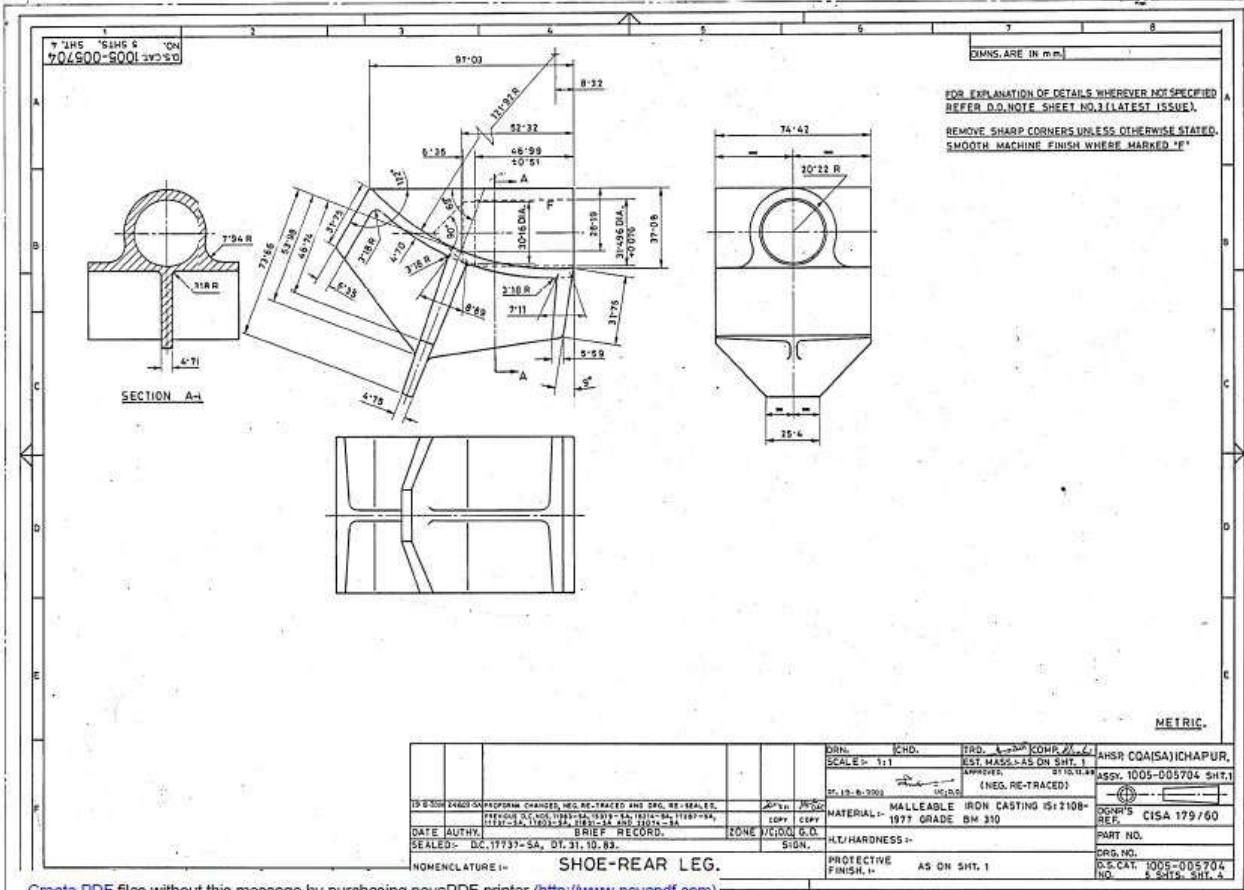

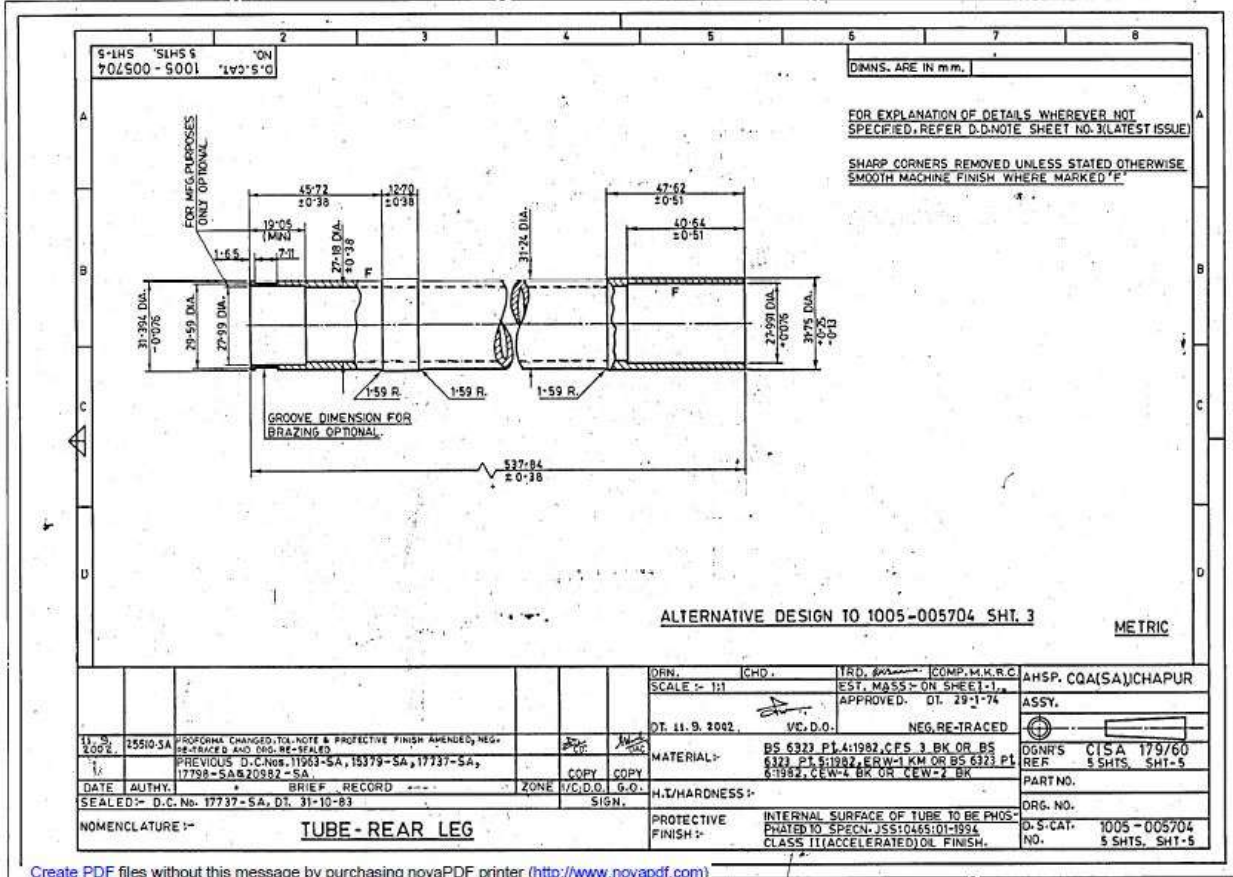

D.F.N.		C.H.D.		TRD. 60		[COMP. M.K.R.C.]		AHSP. CQA(SA) CHAPUR	
SCALE: 1:1				EST. MASS: ON SHEET 1		APPROVED: DT. 29-1-74		ASSY.	
DT. 11.9.2002		VE. D.O.		NEG. RE-TRACED				DGN'S CISA 179/60	
17798-SAB2082-SA		MATERIAL:		BS 6323 Pt. 4:1982, CFS 3 BK OR BS 6323 Pt. 5:1982, ERW-1 KM OR BS 6323 Pt. 6:1982, CEW-4 BK OR CEW-2 BK		REF. 5 SHTS. SHT-5		PART NO.	
DATE AUTHY.		BRIEF RECORD		ZONE		I/C, D.O. G.O.		H.T/HARDNESS	
SEALED: D.C. No. 17737-SA, DT. 31-10-83		SIGN.		PROTECTIVE FINISH:		INTERNAL SURFACE OF TUBE TO BE PHOSPHATED TO SPECN. JSS:0465:01-1994 CLASS II (ACCELERATED) OIL FINISH.		DRG. NO.	
NOMENCLATURE: TUBE - REAR LEG								D.S.-CAT. NO. 1005-005704 5 SHTS. SHT-5	

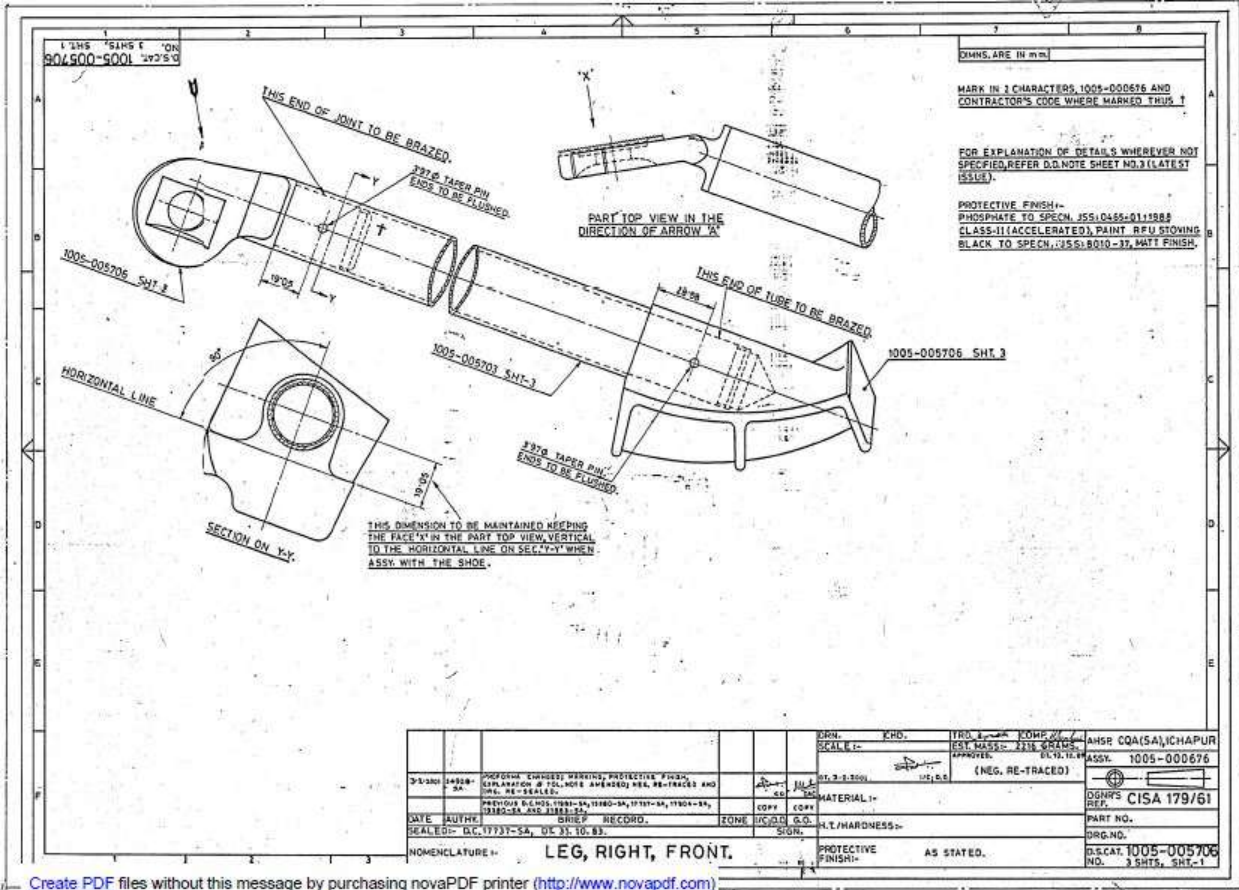

DIMS. ARE IN INCH.
 MARK IN 2 CHARACTERS, 1005-000676 AND CONTRACTOR'S CODE WHERE MARKED THIS ↑
 FOR EXPLANATION OF DETAILS WHEREVER NOT SPECIFIED, REFER D.D. NOTE SHEET NO. 3 (LATEST ISSUE).
 PROTECTIVE FINISH:-
 PHOSPHATE TO SPECN. J5510455-011588 CLASS-II (ACCELERATED), PAINT RFU STOVING BLACK TO SPECN. J5518010-37, MATT FINISH.

1005-005705 SH1-3 1005-005703 SH1-3 1005-005706 SH1-3		DIM. END. TYP. 2. COMP. 2.2 SEAL E. EST. MASS. 2316 GRAMS APPROVED. 06.19.1961 (NEG. RE-TRACED)	ANSR CQA(SA), ICHAPUR ASSY. 1005-000676
3776 TAPER PIN ENDS TO BE FLUSHED	3776 TAPER PIN ENDS TO BE FLUSHED	MATERIAL:- COPY COPY G.O. SIGN.	DGN/RS REF. CISA 179/61 PART NO. DRG. NO. D.D. CAT. 1005-005706 NO. 3 SH15, SH1-1
DATE 14/07/61 SEALER:- DC, 1133-54, DL 31 TO 83		PROTECTIVE FINISH:- AS STATED.	

LEG, RIGHT, FRONT.

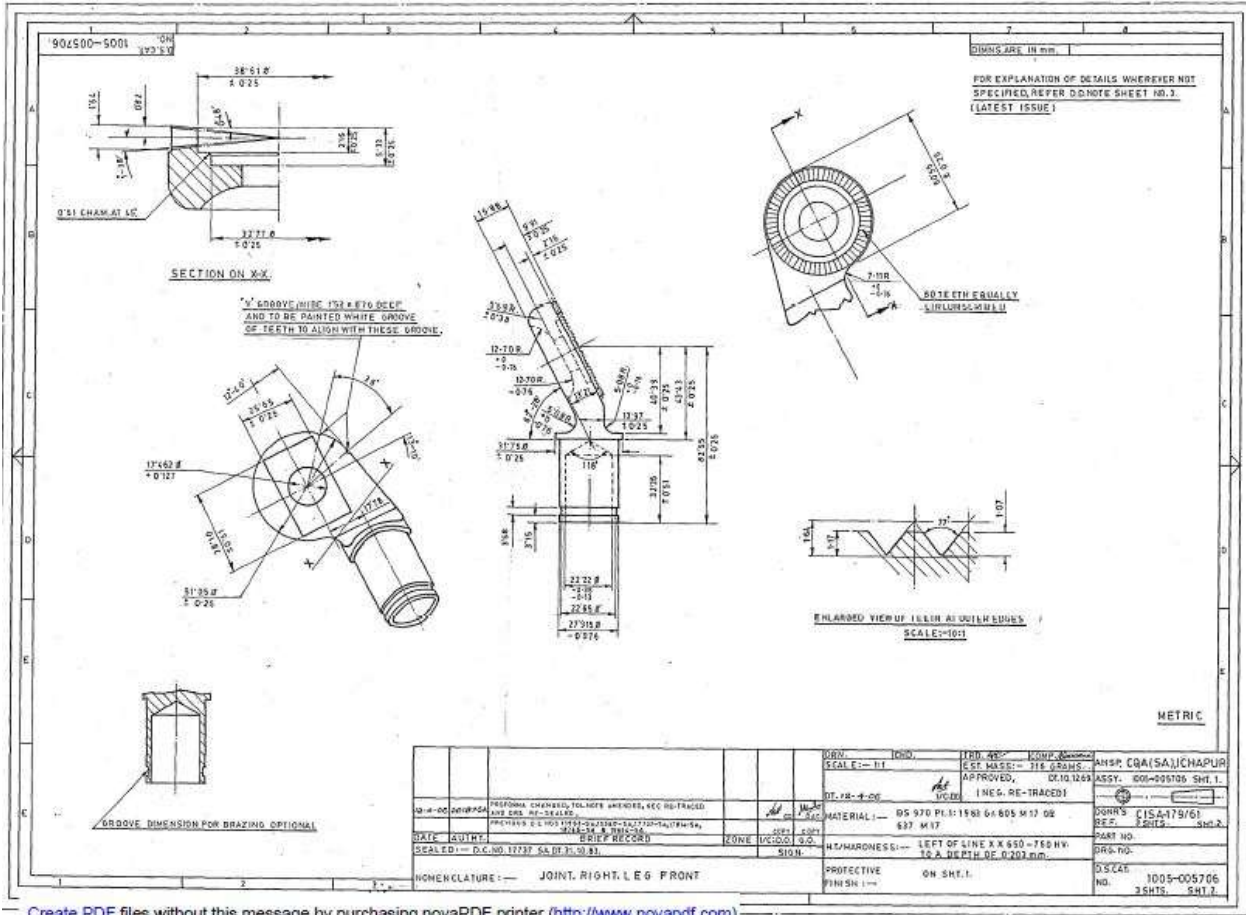

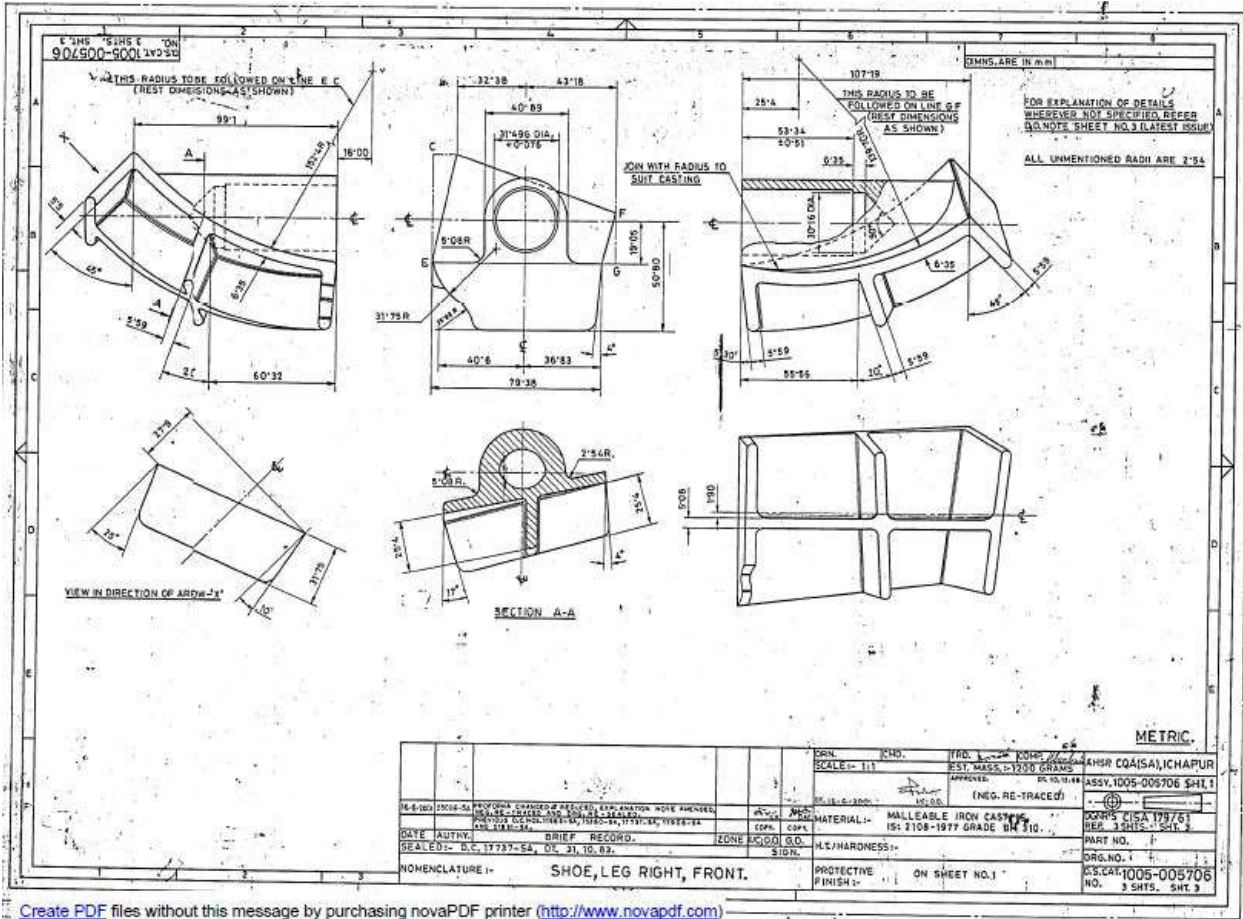

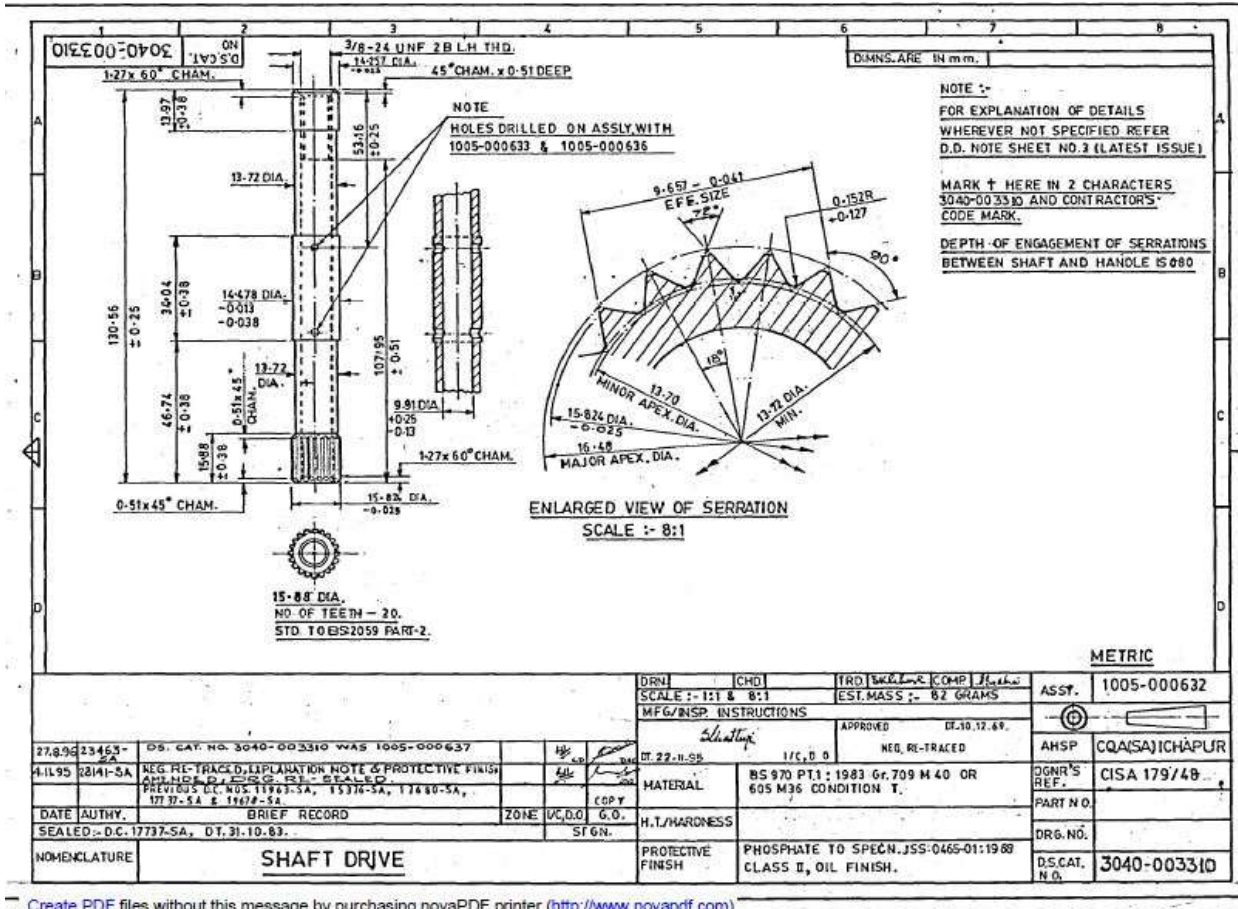

NOTE :-
 FOR EXPLANATION OF DETAILS
 WHEREVER NOT SPECIFIED REFER
 D.D. NOTE SHEET NO.3 (LATEST ISSUE)
 MARK † HERE IN 2 CHARACTERS
 3040-003310 AND CONTRACTOR'S
 CODE MARK.
 DEPTH OF ENGAGEMENT OF SERRATIONS
 BETWEEN SHAFT AND HANDLE IS 880

METRIC

DRN	CHD	TRD	TRD	TRD	TRD	TRD	TRD	ASST.	1005-000632
SCALE :- 1:1 & 8:1								EST. MASS :- 82 GRAMS	
MFG/INSP INSTRUCTIONS								APPROVED DT. 10.12.69.	
27.893	23453-2A	D.S. CAT. NO. 3040-003310 WAS 1005-000637						AHSP	
4.1195	28141-5A	NEG. RE-TRACED, EXPLANATION NOTE & PROTECTIVE FINISH APPLIED & DISC RE-SEALED.						CQA(SA)ICHAJUR	
DATE AUTHY.		BRIEF RECORD		ZONE		U.C.D.O.		G.O.	
SEALED - D.C. 17737-5A, DT. 31.10.63.									
NOMENCLATURE		SHAFT DRIVE						DRG. NO.	
								D.S. CAT. NO.	
								3040-003310	
		PROTECTIVE FINISH						PHOSPHATE TO SPECN. JSS-0465-01:1969 CLASS II, OIL FINISH.	

559700-021C

ON DRAWING CONVENTIONS CONFORM TO JSG-0104.
1973 S.D. DIMNS. ARE IN MM.

MARKING (SUITABLY) ON SAMPLE/TAG.

† Yr. OF Mfg.

* MANUFACTURER'S CODE.

⊗ D.S. CAT. NO.

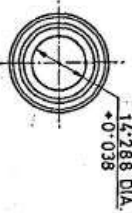
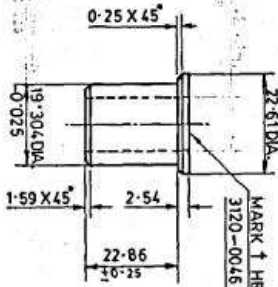

NOTE:-
FOR EXPLANATION OF DETAILS WHEREVER NOT SPECIFIED
REFER D.D. NOTE SHEET NO.3 (LATEST ISSUE).

1-06-06	26216-SA	PROFORMA CHANGED, NEGATIVE RE-TRACED AND DRAWING RE-SEALED.							
DATE	AUTHY.	PREVIOUS D.C. NOS. 11863-SA, 13376-SA, 16732-SA, 16291-SA, 16321-SA, 17151-SA, 18131-SA, 18133-SA, 18135-SA, 18136-SA, 18137-SA							
SCALE:-	1:1	TRD. SHEET NO. 1	COMP. SHEET NO. 1						
DRN.	CHD.	17714-SA	DI. 26.10.83						
SEAL ED:-	D.C. NO.	17714-SA	DI. 26.10.83						
DI. 1-06-06	EST. MASS:-	37 GRAMS	APPROVED. DI. 10.12.69						
	MATERIAL:-	BS 2874 PB 102M OR IS: 7811	VEG. D.O. (NEGATIVE RE-TRACED)						
	H.T./HARDNESS:-								
	PROTECTIVE FINISH								
	NOMENCLATURE	BEARING SLEEVE							
	D.S. CAT. NO.	3120-004653							

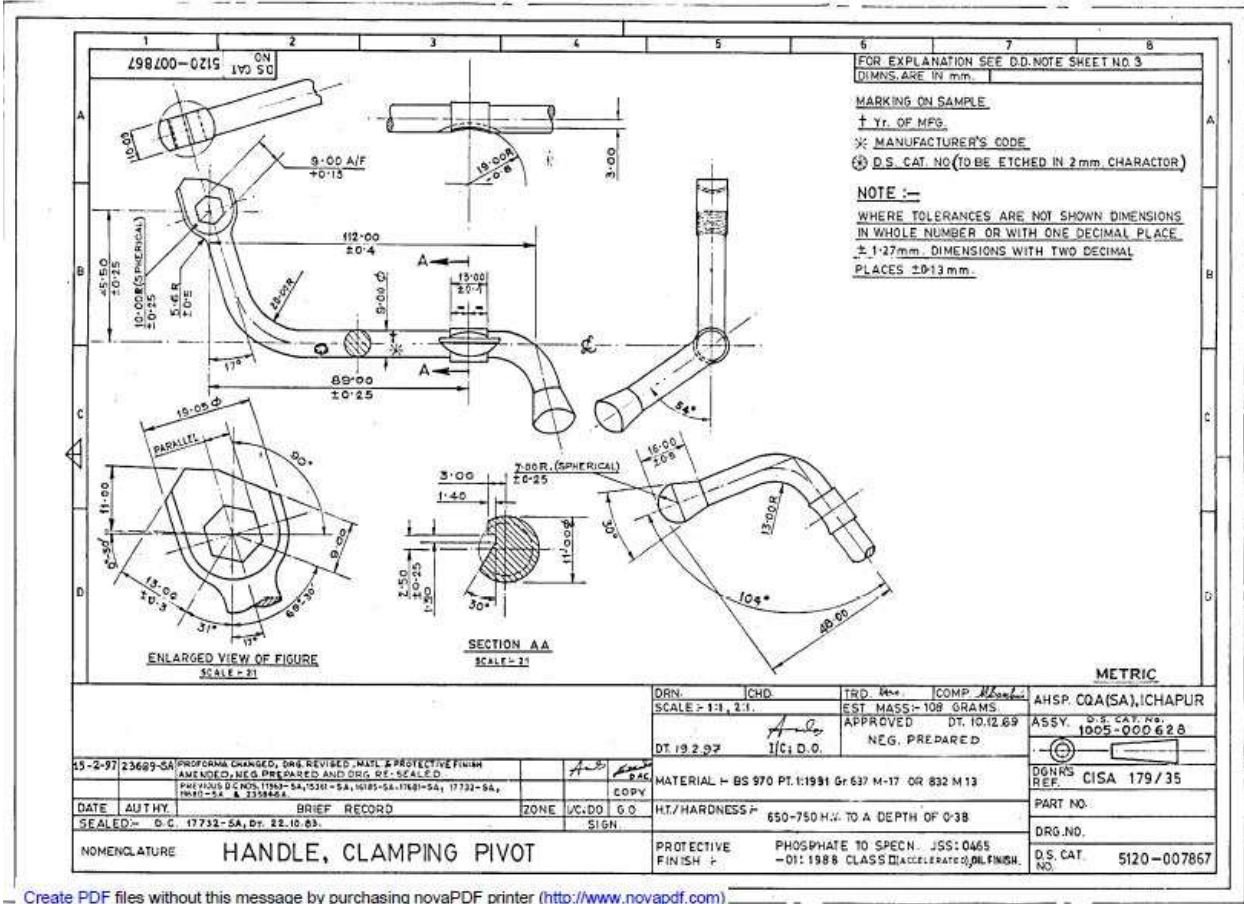

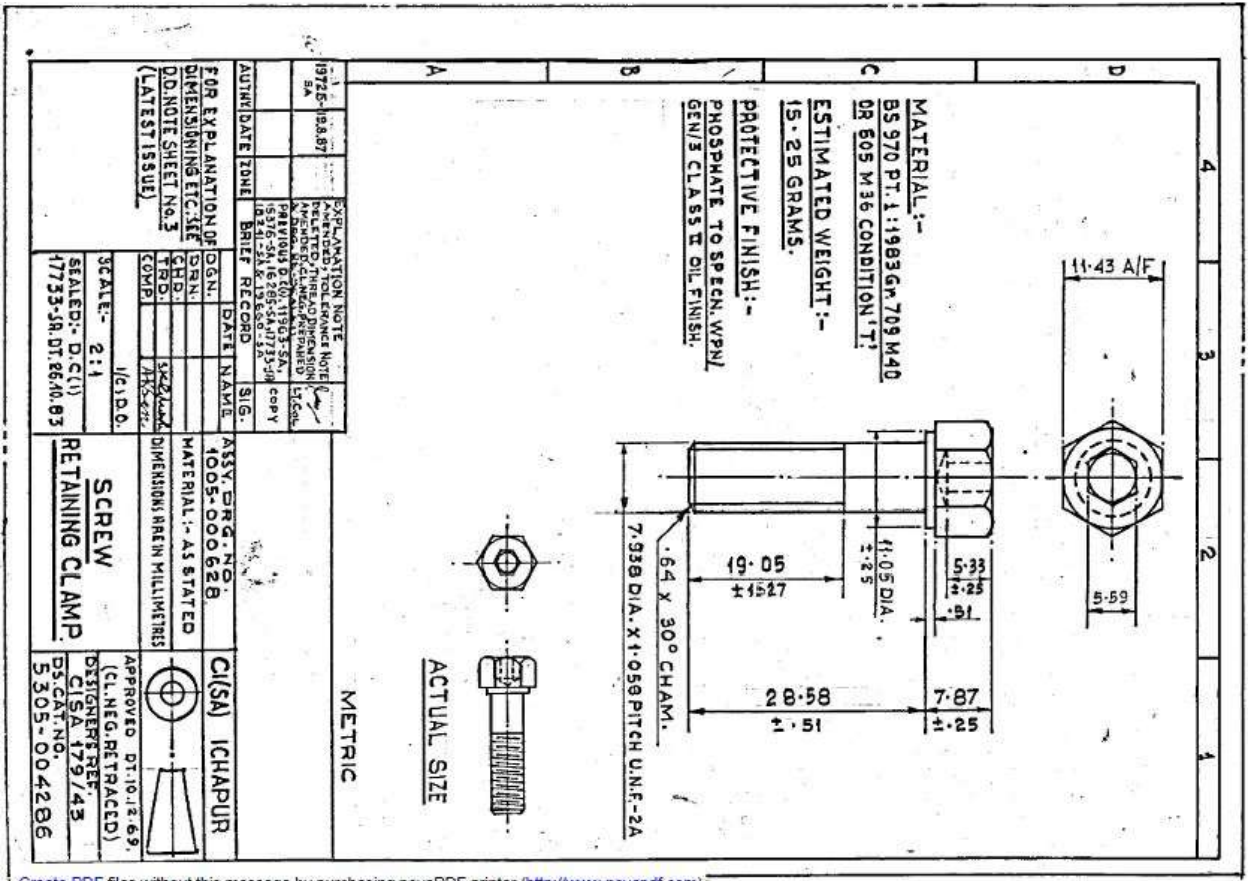

1972E-193.87		EXPLANATION NOTE AMENDED TOLERANCE NOTE AS PER THE DIMENSION AS SHOWN IN THE DRAWING 15/10/01 16:28:14 CD32A 15/11/21 13:55:00 J53598 copy	
AUTOMATED FROM		BRIEF RECORD	
FOR EXPLANATION OF DIMENSIONING ETC. SEE DRAWING SHEET NO. 2 (LATEST ISSUE)		DATE NAME SIG.	
SCALE:- 2:1		ASSY. DRG. NO. 1005-000628	
SEALD:- D,C(1)		MATERIAL:- AS STATED	
17733-JR.DT.26/0.03		DIMENSIONS ARE IN MILLIMETRES	
		C(SA) ICHAPUR	
		APPROVED DT:10.12.09 (CL. NEG. RETRACED)	
		DESIGNER/REF C(SA) 179/43	
		DSCAT. NO. 5305-004206	

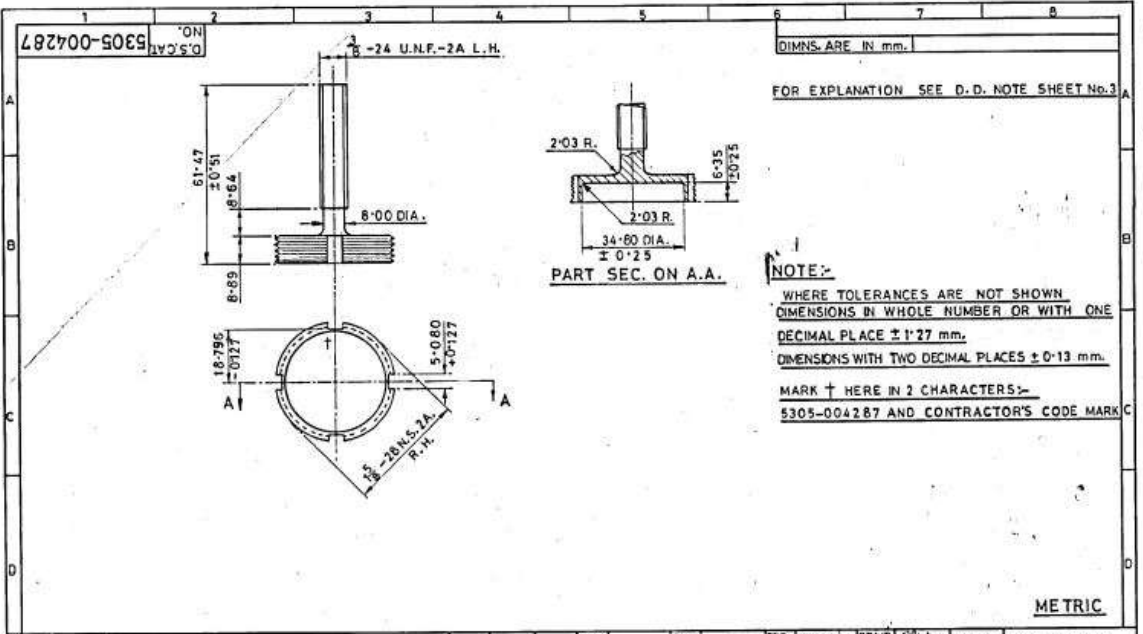

DIMNS. ARE IN mm.
FOR EXPLANATION SEE D.D. NOTE SHEET No.3

NOTE:-
WHERE TOLERANCES ARE NOT SHOWN
DIMENSIONS IN WHOLE NUMBER OR WITH ONE
DECIMAL PLACE ± 1.27 mm.
DIMENSIONS WITH TWO DECIMAL PLACES ± 0.13 mm.
MARK † HERE IN 2 CHARACTERS:-
5305-004287 AND CONTRACTOR'S CODE MARK

METRIC

DRN		CHD	TRD	COMP	ASSY.	1005-000628
SCALE: 1:1		MFG./INS. INSTRUCTIONS		EST. MASS:- 6.2 GRAMS.	APPROVED DT 10.12.69 NEG. RE-TRACED	
208896	23454 - SA	PROFORMA CHANGED, PROTECTIVE FINISH & MATERIAL AMENDED, NEG. RE-TRACED & DRG. RE-SEALED		DT. 21.8.96	A H S P	QQA(SA) ICHAPUR
DATE AJJTHY. SEALED:- D. C. 17733-SA, DT. 26.10.63		BRIEF RECORD		ZONE	IC.D.O.	G.O.
NOMENCLATURE		SCREW, TRAVERSING.		MATERIAL		HS:970 PT.1:1991 GR.709 MA0 OR 605 M 36 CONDITION 'T'
		SIGN.		H.L.HARDNESS		PROSPHATE TO SPECN. J55.0465-01:1988 CLASS III(ACCELERATED)DL FINISH
				PART No.		DRG. No.
				D.S. CAT NO.		5305 004287

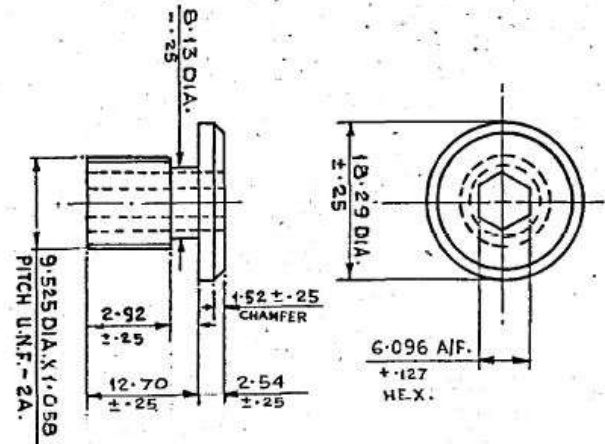

MATERIAL:-
 BS 970 PT.1: 1983 Gr 080
 M 40

PROTECTIVE FINISH:-
 PHOSPHATE TO SPECN. W/PN/
 GEN/3 CLASS II OIL FINISH.

1777-13/087 SA	EXPLANATION NOTE: 2. THREAD DIM. AMENDED. TOLERANCE NOT DELETED. DRAWING RE-TRACED AND RE-SEALED. 3. PREVIOUS D.L(D) NO: 11963 SA, 1537-2A, 16285-5A, 17734-8A, 18241-50L, 19708-8B	MAJ	COPY
AUTHY/ DATE ZONE	BRIEF RECORD	SIG.	
FOR EXPLANATION OF DIMENSIONING ETC SEE DD NOTE SHEET NO.3 (LATEST ISSUE)	DESIGNER: <i>AK</i>	DATE:	NAME:
	CHKD:		
	TRD:		
	COD:		
	SCALE:- 2:1		
	SEALED:- D.C.(1)		
	17734-8A, DT.26.10.83		
	ASSY DRG. NO. 1005-000678		
	MATERIAL:- AS STATED		
	DIMENSIONS ARE IN MILLIMETERS		
	SCREEN CAP SOCKET HEAD		
	DESIGNER'S REF. CISA 179/52		
	5305-004285		

METRIC

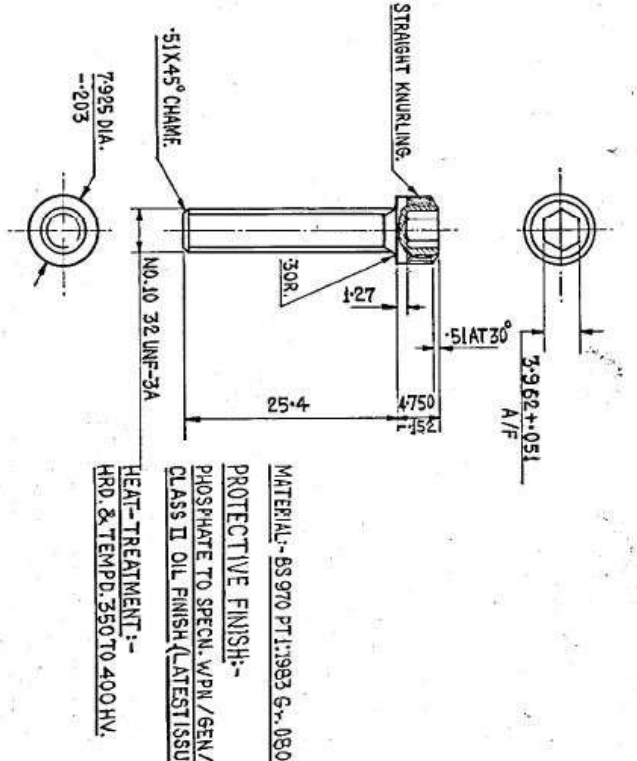

MATERIAL:- BS 970 PT.1:1993 Gr. 080N40

PROTECTIVE FINISH:-
PHOSPHATE TO SPECN. W/PN/GEN/3
CLASS II OIL FINISH (LATEST ISSUE)

HEAT-TREATMENT:-
HRD. & TEMPD. 350 TO 400 HV.

METRIC

20333- SA	28.12.09	CL. NEG. PREPARED & DRG. RE-SEALED. PREVIOUS DCG NO: 10242663-3A 15529-3A/17737-3A 17737-3A/17737-3A	DATE	NAME	ASSY. DRG. 1005-000632	COAS(SA) CHAPUR.
FOR EVALUATION OF DIMENSIONING ETC. SEE D.DIAGNOSTIC SHEET NO. 3(LATEST ISSUE)			DATE	NAME	MATERIAL: AS STATED	SCREW, CAP, SOCKET HD.
			BRIEF RECORD	SIG.	DIMENSIONS ARE IN MILLIMETRES.	HEX. NO. 10 32 UNF.
			DGN.			3A x 25.4 LONG.
			DRN.			
			CHKD.			
			APPD.			
			DATE	NAME		
			SCALE:-	2:1		
			SEALING	06(D)17737-3A		
			DT.	31-10-83		
			APPROVED		CL. NEG. PREPARED	DESIGNER'S REF.
					CI SA / 373	5305-004854
					DS. CAT. NO.	

5305-004855

ALL DIMENSIONS ARE IN MM.

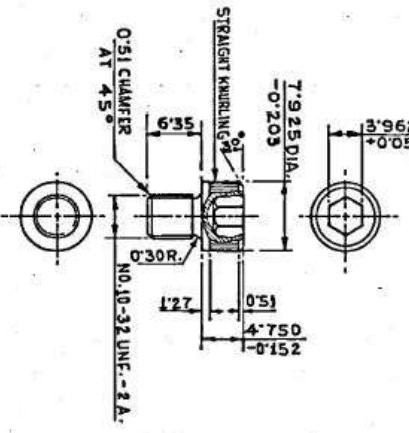

FOR EXPLANATION OF DETAILS WHEREVER NOT SPECIFIED REFER D.D. NOTE SHEET NO. 3 (LATEST ISSUE).

METRIC

216134137494	NEG. RETRACED AND DRG. RE-SEALED	CD	60
AUTHY. DATE	ZONE	BRIEF RECORD	CD
SEALED:- D.C. 7737-5A, DT. 31.10.83			
DGN. DRN.	CHD.	TRD. SIGNED/COMP. SIGNED	ASSY. 1005-000632
APPROVED	DT. 29.11.84	EST. MASS	SCALE: 2:1
MATERIAL	BS 970 Pt. 1:1983 Gy.080 W.40	REF. DET.	CISA/375
HARDNESS	HARDENED & TEMPERED 350-400 HV.	REF. DET.	BRIS. SUC.
SURFACE FINISH	PHOSPHATE TO SPECN. J55 04-65-01:3988 CLASS II (ACCELERATED), OIL FINISH.	PART NO.	
FINISH		ANSP.	COA(SA) 1CHAPUR
NOMENCLATURE	HEX. NID-32 UNF ZAV635 LONG.	D.S. CAT. NO.	5305-004855

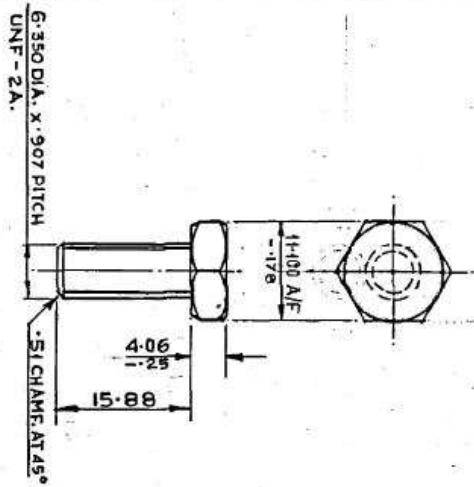

MATERIAL :-
BS 970 PT.1:1983 GR.080 M40.

PROTECTIVE FINISH :-
PUDSPRPHATE TO SPECN. W/PN/
GEN/3 CLASS II OIL FINISH.

HEAT TREATMENT :-
HARDENED & TEMPERED
350 TO 400 HV.

METRIC

19774-1340.87 SA		EXPLANATION NOTE: THREAD DIM. AND REFACE TO BE RE-TRACED AND RE-SEAL'D WAS		PREVIOUS D.C. (1) NOS. 11963-SA, 15391-SA, 17233- SA, 17764-SA & 19708- SA.		SIGNATURE	
AUTHY. DATE		ZONE		BRIEF RECORD		SIG.	
FOR EXPLANATION OF DIMENSIONING ETC SEE D.D NOTE SHEET No. 3 (LATEST ISSUE)							
DGN.		DATE		NAME		SIGNATURE	
DRN.							
CHD.							
TRD.							
COMP.							
SCALE:- 2:1		SCALE:- 1/6:0.0		SEALD:- D.C. (1)		17733-SA, DT. 26.10.83	
ASSY. DRG. NO. 1005-00062B		MATERIAL:- AS STATED		DIMENSIONS ARE IN MILLIMETERS		CIS(A) CHAPUR	
SCREW HEX. HD. SCREWED TO HEAD 6:350 DIA. X .907		PITCH UNF - 2A x 15.88		LONG		APPROVED DT. 29.1.74 (CL. NEG. RETRACED)	
DESIGNER'S REF. CISA/377		DESIGNER'S REF. CISA/377		D.S. CAT. NO. 5305-004856			

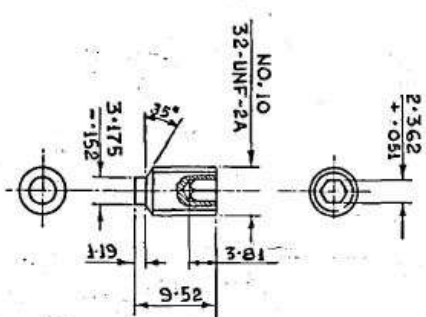

MATERIAL:-
BS 970 Pt. 1:1983 Gr 70 9 M40 OR
605 M 36

PROTECTIVE FINISH:-
PHOSPHATE TO SPECN. JSS 0465-01:
1989, CLASS II, OIL FINISH.

HEAT-TREATMENT:-
HRD. & TEMPD. 400 TO 500 H.V.

FOR EXPLANATION OF DIMENSIONING
ETC, SEE D.D. NOTE SHEET NO. 3
(LATEST ISSUE)

METRIC

20976-31.10.90	CL. NEG. RETRACED & DRAWING RESAMPLED	SSG
SA	PREVIOUS P.2.0 (M01983-54) 1980-54, 1983-54, 1984-54	COPY
AUTHY. DATE	ZONE	BRIEF RECORD
		SIG.
	DATE	NAME
	DGN.	
	DRN.	
	TRD.	5-9-90 <i>[Signature]</i>
	COMP.	5-9-90 <i>[Signature]</i>
	SCALE:- 1:2:1	
	SEALED:- D.C. (017733-54, DT. 26.10.83)	
	ASSY. DRG 1005-000674	CQA(SA) ICHAPUR
	1005-000667 & 1005-000676	
	MATERIAL:- AS STATED	
	DIMENSIONS ARE IN MILLIMETRES	
	APPROVED. DT. 29.1.74	
	SCREW SET SOCKET HEX	(CL. NEG. RETRACED)
	NO. 10 32 UNF-2A X 9.52	DESIGNER'S REF.
	LONG. HALF DOG POINT	C15A - 372
		D5-CAT. NO.
		5305-004857

858700-506 5 DRAWING CONVENTIONS CONFORM TO JS6-0104
 DIMENSIONS ARE IN mm. GEN. TOL.

MARKING (SUITABLY) ON SAMPLE/TAG
 + Yr. OF Mfg.
 * MANUFACTURER'S CODE
 @ D.S. CAT. NO.

FOR EXPLANATION OF DETAILS
 WHEREVER NOT SPECIFIED, REFER
 TO NOTE SHEET NO. 3 (LATEST ISSUE)

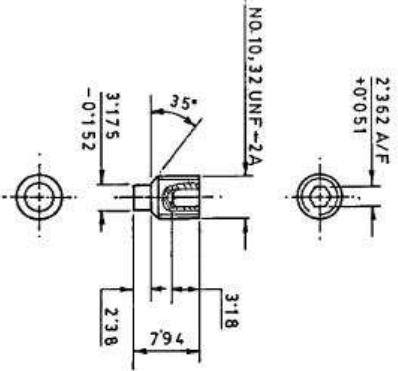

11-04-06		26/186-		PROGRAM CHANGED PROTECTIVE FINISH AMENDED.			
PREVIOUS D.C. NOS. 11983-SAJ5381-SAJ734-SAJ755-SAJ 19709-SAJ2095-SAJ AND 22872-SAJ.							
DATE	AUTHY.	BRIEF RECORD					
SEALING	D.C. NO. 17734-SAJ, DT: 26.10.83.						
DRN.	CHD.	TRD: W	COMP. SIGN: S				
SCALE: -2:1		EST. MASS: -					
DI. 11-04-06	I/C.D.O.	APPROVED	DT. 29.1.94	AHSP CQA(SAJ)CHAPUR			
MATERIAL: - BS. 970.P1.1:1983 Gr. 709 M 4.0 OR 605 M 35.				ASSY. 1005-000678			
H.T/HARDNESS: - HARD. & TEMPD. 400 TO 500 HV.				DGNR'S REF. CISA/378			
PROTECTIVE FINISH: - PHOSPHATE TO SPECN.JSS. 0465-01:1994 (NEG. RETRACED), OIL FINISH.				PART NO.			
NOMENCLATURE: - 32 UNF-2A X 7.94 LONG				DRG. NO.			
FULL DOG POINT.				D.S. CAT. NO. 5305-004858			

5305-00-5055

ON DRAWING CONVENTIONS CONFORM TO J56-0104
 ALL DIMENSIONS ARE IN MM.

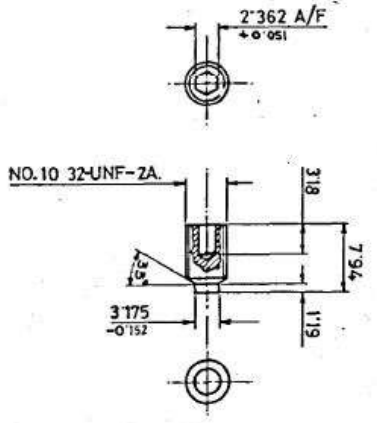

NOTE:-
 FOR EXPLANATION OF DETAILS WHEREVER
 NOT SPECIFIED REFER TO NOTE SHEET
 NO. 3 (LATEST ISSUE)

METRIC

19-5-95	29902-SA	PROTECTIVE SHEATH ASSEMBLY, NEG. RE-TRACTED #002A, RE-TRACTED	54	1/201
DATE	AUTHY	BRIEF RECORD	ZONE	V/G: D.O. G.O.
SEAL ED:	DC NO 17734-SA	DT 26.10.83	TRD	COMP
DRN	CHD	EST. MASS	ASSY	DS CAT NO.
SCALE :-	2:1			1005-000678
MFG/INSP INSTRUCTIONS		APPROVED	DT. 29.11.74	
DR. 24.1.95.		NEG. RE-TRACTED		
MATERIAL.	BS 970 PT. 1:1983 Gr. 709	AHSP	CQA (SA), ICHAPUR	
	M 40 OR 605 M 36	IGNRS	CISA - 379	
HT/HARDNESS.	HARD& TEMPD. 400 TO 500 HV.	REF.		
PROTECTIVE FINISH.	PHOSPHATE SPECN. JSS 0465-01: 1988 CLASS D, OIL FINISH.	PART NO.		
NOMENCLATURE.	SCREW SET SOCKET HEX NO. 10 32-UNF-2AX794 LONG. HALF DOG POINT.	DRG. NO.		
		DS CAT.		5305-004859

098700-5305

NO. DIMS. ARE IN mm

3.962 A/F
+0.051

FOR EXPLANATION OF DETAILS
WHEREVER NOT SPECIFIED REFER
TO NOTE SHEET NO.3 (LATEST
ISSUE).

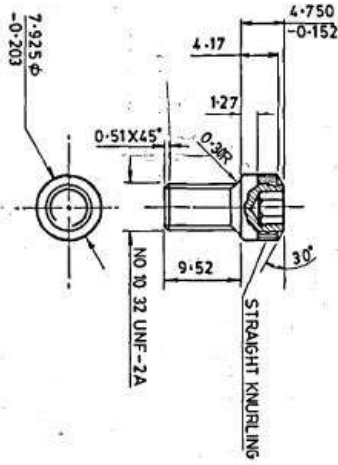

METRIC

23-6-06	26229-SA	PROFORMA CHANGED, TOL. NOTE AND PROTECTIVE FINISH SPEC. AMENDED, NEGATIVE RE-TRACED AND DRG. RESEALED.	19708-SA & 20333-SA	19708-SA & 20333-SA	19708-SA & 20333-SA
DATE	AUTHY	BRIEF RECORD	ZONE	I/CDO	G.O.
DRN	ICHD	TRD	COMP	EST. MASS	DT 29.1.74
SCALE:-		APPROVED	NEGATIVE RE-TRACED	ASSY. 1005-000627	
DT. 23-6-06	1/31 D.O.				
MATERIAL:-	BS 970 PT. 1.1963 Gr. 080 M 40				
H.T./HARDNESS:-	HARDENED & TEMPERED 350 TO 400 HV.				
PROTECTIVE FINISH:-	PHOSPHATE TO SPEC. JSS 0465-01:1994 CLASS II (ACCELERATED) OIL FINISH.				
NOMENCLATURE:-	NO 10. 32 UNF-2A X 9.52 LONG.				
	SCREW CAP SOCKET HD. HEX.				
	D.S. CAT. NO. 5305-004860				

198700-5035 ON

173 SQ

DIMENSIONS IN M.M.

FOR EXPLANATION OF DETAILS WHEREVER NOT SPECIFIED, REFER D.D NOTE SHEET NO.3 (LATEST ISSUE).

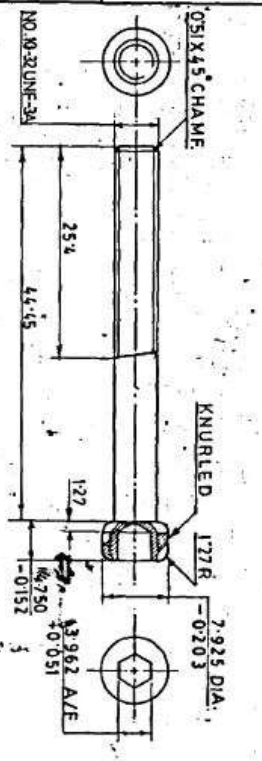

HEAT TREATMENT :-
HARDENED & TEMPERED 350 TO 400 H.V.

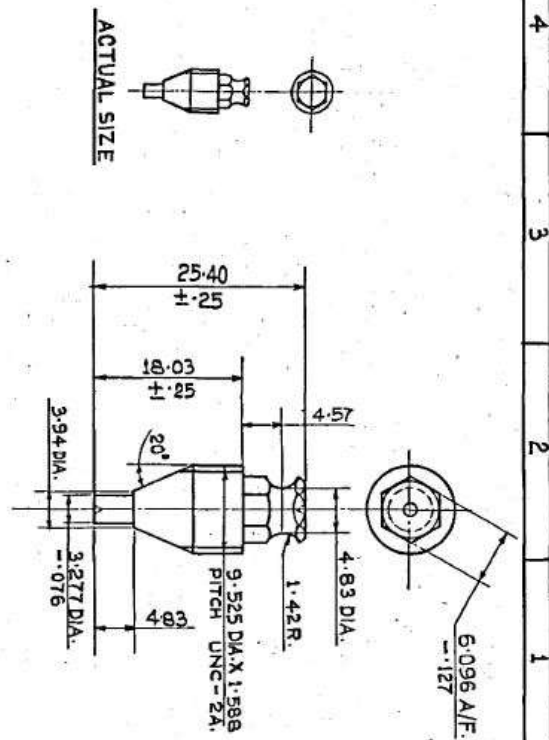

Q-12-2002	25614-5A	PROGRAMMA HANDLED, PROTECTIVE FINISH & TOLERANCE AMENDED, NEG. RE-TRACED AND SHG. RE-SEALED.						
		PREVIOUS DCNOS. 1982-5A, 1938-5A, 1987-5A, 1972-5A, 1984-5A, 1970-5A AND 2042-5A.						
DATE	AUTHY	BRIEF RECORD						
SEALED:-	DCN.O.1772-5A DT. 22.10.83							
DBN	CHD.	TRD. <i>[Signature]</i>	AHSP.CQ(A)(CHAPUR.					
SCALE: 2:1		EST. MASS.	ASSY. 1005-000627					
DT. 10-12-2002	VC, D.O.	APPROVED, DT. 29.1.76.	NEG. RE-TRACED.					
MATERIAL :-	ES 970 P1J:1983 G-080 M40							
HT/HARDNESS :-	AS STATED							
PROTECTIVE FINISH :-	PHOSPHATE TO SPECN. JSS 0465-01:1994 CLASS III (ACCELERATED), OIL FINISH.							
NOMENCLATURE :-	SCREW CAP SOCKET HD.		DGNRS REF. CISA/374					
	HEX. NO. 10 32 UNF 3A X 44.45 LONG.		PART NO. DRG. NO.					
	HEX. NO. 10 32 UNF 3A X 44.45 LONG.		DS. CAT. NO. 5305-004861					



MATERIAL:-
B5970 PT.1:1983 Gr-A17 M40
HEAT TREATMENT:-
HARDENED AND TEMPERED TO
500 - 550 HV EXCEPT TIP PORTION.
ESTIMATED WEIGHT:- 7 GRAMS.

METRIC

EXPLANATION NOTE & TOLERANCE NOTE	DATE	NAME	SIG.
1977B-13.10.87			
EXPLANATION NOTE & TOLERANCE NOTE SA RELEASED, DES. RETRACED PREVIOUS P&O NOS. 11893-34 15376-SA, 17733-A 17733-SA, 18487-54 & 1978-V			MAE COPY
AUTHY	DATE	ZONE	BRIEF RECORD
FOR EXPLANATION OF DIMENSIONING ETC.	DGN.		
SEE D.D. NOTE SHEET	CHKD.		
NOS 3 (LATEST ISSUE)	TRD.		
	COMP.		
	SCALE:- 2/1 & 1/1.		
	SEALED:- DCI.		
	17733-SA, DT 26-10-83.		
ASSY. DRG. 1005-000628	CISA	IGHAPUR.	
MATERIAL:- AS STATED			
DIMENSIONS ARE IN MILLIMETRES			
SCREW			
LOCKING RING			
APPROVED. DT 10-11-86 (CL. NEG. RE-TRACED)			
DESIGNERS REF.			
CISA 179/42			
DSCAT NO.			
5305-005126			

	4	3	2	1
D				
C	<p>MATERIAL :- BS 970 PT.1 : 1983 Gr.045 M-10 OR 210 M-15.</p> <p>HEAT TREATMENT :- CASE HARDENED AT THE CONICAL PORTION TO A DEPTH OF .20 650 - 750 HV.</p> <p>PROTECTIVE FINISH :- SEE ON ASSY. DRG.</p> <p>NOTE :- PORTION 'A' TO BE LEFT SOFT FOR RIVETTING.</p>			
B	 <p>SCALE :- 5/1</p>			
A	<p>EXPLANATION NOTE ARRANGED, TOLERANCE NOTE DELETED, DIMENSIONING RE-TRACKED AND CORRECTED SERIOUS CORRECTIONS ISSUED ON 17/7/83 17819-5A5, 18711-5A1 COPP, NVAJ.</p> <p>1977/6 13.10.87 - SA</p>			
METRIC				
AUTHY. DATE ZONE		BRIEF RECORD SIG.	DATE NAME	
FOR EXPLANATION OF DIMENSIONING ETC. SEE DD NOTE SHEET NO.3 (LATEST ISSUE)				
DESIGNED BY	DGN.	DRAWN BY	CHKD. BY	
TRD.		TRD.		
CORNER				
SCALE :- 1/4" = 1".	1/4" = 0.0			
SEALED :- DC(1) 17738-S				
SA DT. 1-11-83.				
ASSY. DRG.	1005-000653	CISA) ICHAPUR		
MATERIAL :-	AS STATED			
DIMENSIONS ARE IN MILLIMETRES				
APPROVED	DT. 10-12-83			
(CL. NEG. RE-TRACED)				
DESIGNER'S REF	CISA. 179/174			
5307-000874				

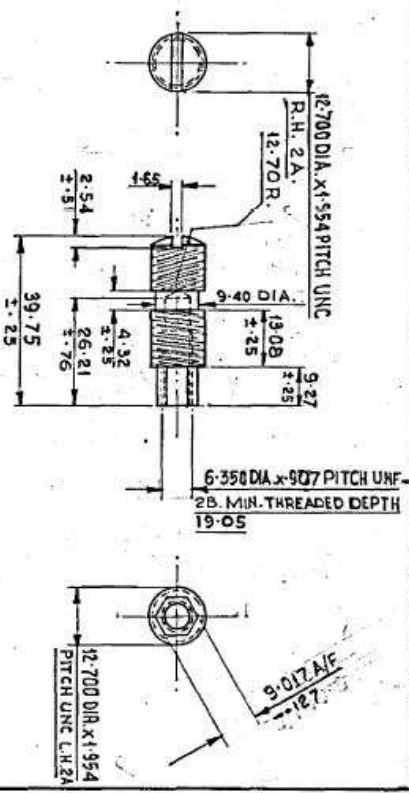

MATERIAL:-
 STEEL S5 970 PT. 1:1903 G. 709
 M40 OR 605 M 36 CONDITION 'U'.
 PROTECTIVE FINISH:-
 PHOSPHATE TO SPECN. WPN/GEN/3
 CLASS II OIL FINISH.
 ESTIMATED WEIGHT:-
 20 GRAMS.

19000- A.H. 87	19000- A.H. 87	PREVIOUS D.C. NO. 11963-98 13090-SA, 15386-SA, COPY 17753-SA, 17794-SA, 18417-SA & 19710-SA	DATE RECORD	SIG	ASSY. DRG. 1005-000628	QA(SA) ICHAPUR
AUTHY. DATE ZONE	BRIEF EXPLANATION OF DIMENSIONING ETC.	BRIEF RECORD	DATE	NAME	MATERIAL:- AS STATED	(CLNG. R. TRACED)
NO. 3 (LATEST ISSU)	SEE DD NOTE SHEET	TRID	SCALE:- 1:1	1/2 D.D.	DIMENSIONS ARE IN MILLIMETERS	DESIGNER'S REF. CISA-179/19/1
			SEALD:- D.C.(1)	17733-SA, DT. 26.10.83		DS. CAT. NO. 5307-000875

STUD CLAMP

METRIC

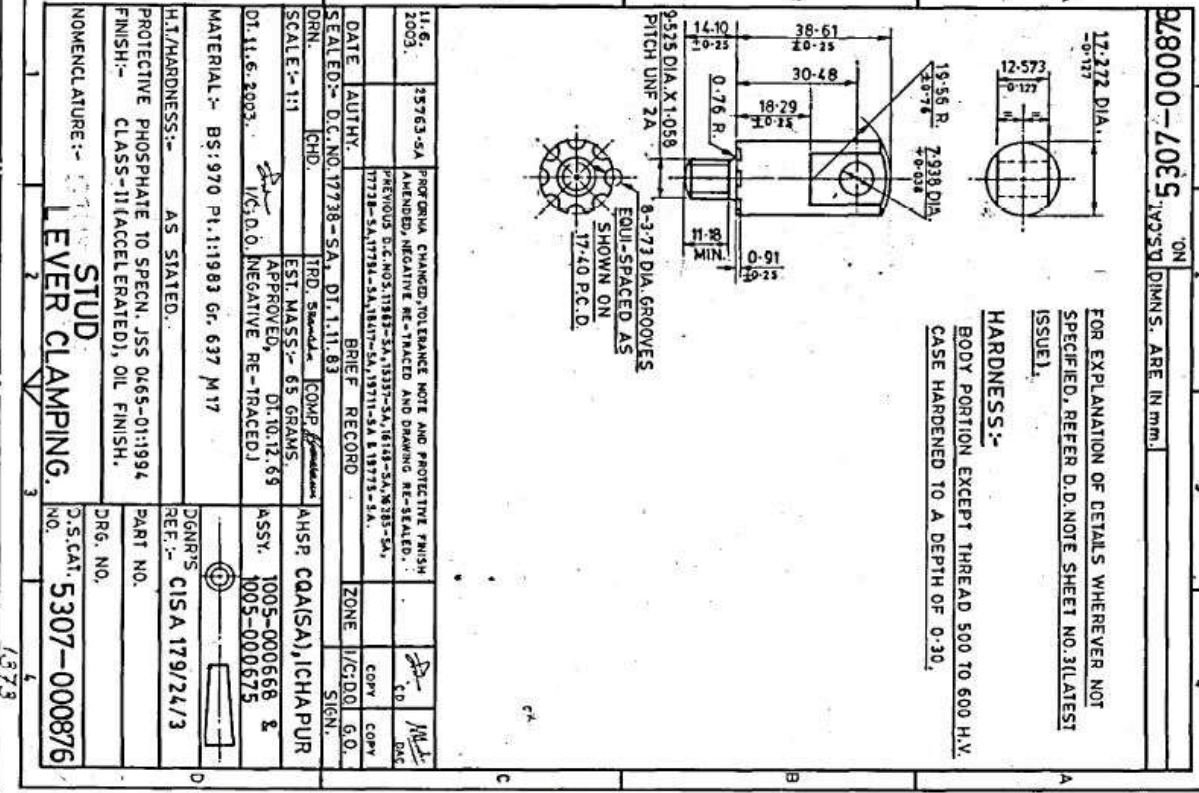

FOR EXPLANATION OF DETAILS WHEREVER NOT SPECIFIED, REFER D.D. NOTE SHEET NO. 31(LATEST ISSUE).

HARDNESS:-
 BODY PORTION EXCEPT THREAD 500 TO 600 H.V.
 CASE HARDENED TO A DEPTH OF 0.30.

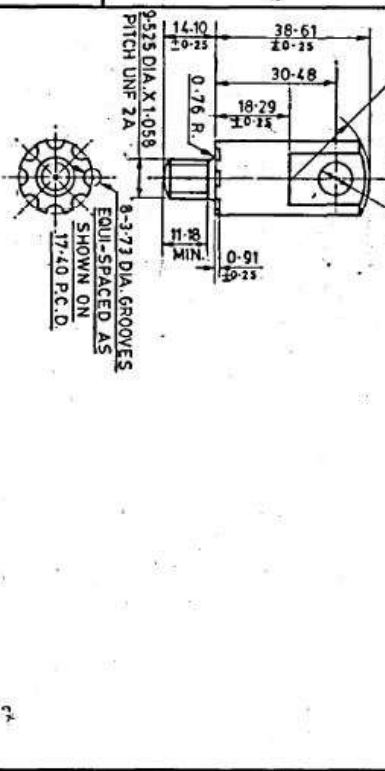

11.6. 2003.	25763-5A	PROGRAMA CHANGED; TOLERANCE NOTE AND PROTECTIVE FINISH AMENDED; NEGATIVE RE-TRACED AND DRAWING RE-SEALED.			
DATE	AUTHTY.	PREVIOUS D.C. NOS: 17738-5A, 17739-5A, 17740-5A, 17741-5A, 17742-5A, 17743-5A, 17744-5A, 17745-5A, 17746-5A, 17747-5A, 17748-5A, 17749-5A, 17750-5A.			
SCALE:-	1:1	TRD. Standard - COMP. <i>Handwritten</i>	EST. MASS:- 65 GRAMS.		
DI. 11.6. 2003.		APPROVED, DI. 10.12.03	ASSY. 1005-000668 &		
MATERIAL:-	BS: 970 P. 1: 1983 Gr. 637 M17	I/C: D.O. [NEGATIVE RE-TRACED]	1005-000675		
H.I./HARDNESS:-	AS STATED.	DRN. [Handwritten]	DGNR'S CISA 179/24/3		
PROTECTIVE PHOSPHATE TO SPECN. JSS 0465-01:1994 FINISH:- CLASS-II (ACCELERATED), OIL FINISH.		SEALING:- D.C. NO. 17738-5A, DI. 1.11.03	PART NO.		
NOMENCLATURE:-	STUD	BRIEF RECORD	DRG. NO.		
	LEVER CLAMPING.	ZONE I/C: D.O. G.O. SIGN.	D.S. CAT. NO. 5307-000876		

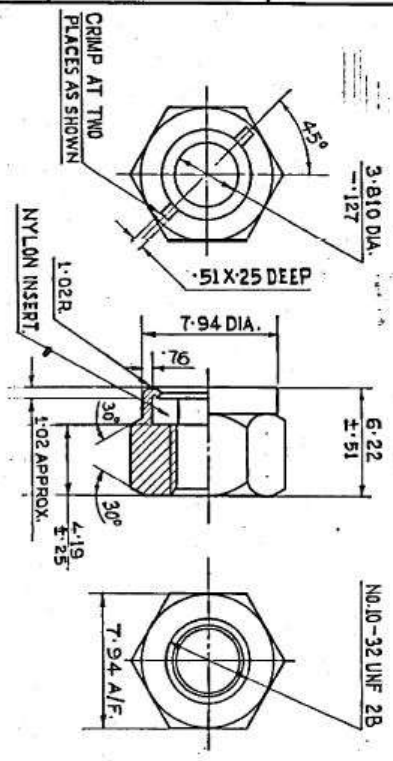

MATERIAL :-
 BS 970 PT. 1:1983 Gr. 220 M 07.
 PROTECTIVE FINISH :-
 ZINC PLATING TO SPECN IS: 1573-
 GRADE-B EXCEPT THREADED &
 NYLON PORTION.

METRIC

19776	13/08/87	EXPLANATION NOTE AMENDED TOLERANCE NOTE DELETED, DRAWING RE-SEALED AND RE-TRACED	MAJ
19776	13/08/87	PREVIOUS DRAFT NOS. 11983-SA, 19340-3A, 0732-SA, 0731-0A, 0848-0A	MAJ
AUTHY DATE ZONE		BRIEF RECORD	SIG.
FOR EXPLANATION OF DIMENSIONING ETC		DATE	NAME
SEE DD NOTE SHEET NO.3. (LATEST ISSUE)		DGN.	
		DRN.	
		CHD.	
		TRD.	
		COMB.	
SCALE:- 4:1		APPROVED DT 10/7/85	
SEALED:- DC(U)		DESIGNER'S REF.	
17732-SA, DT-22-10-83		CISA 289	
		DSCAT NO.	
		5310-003305	

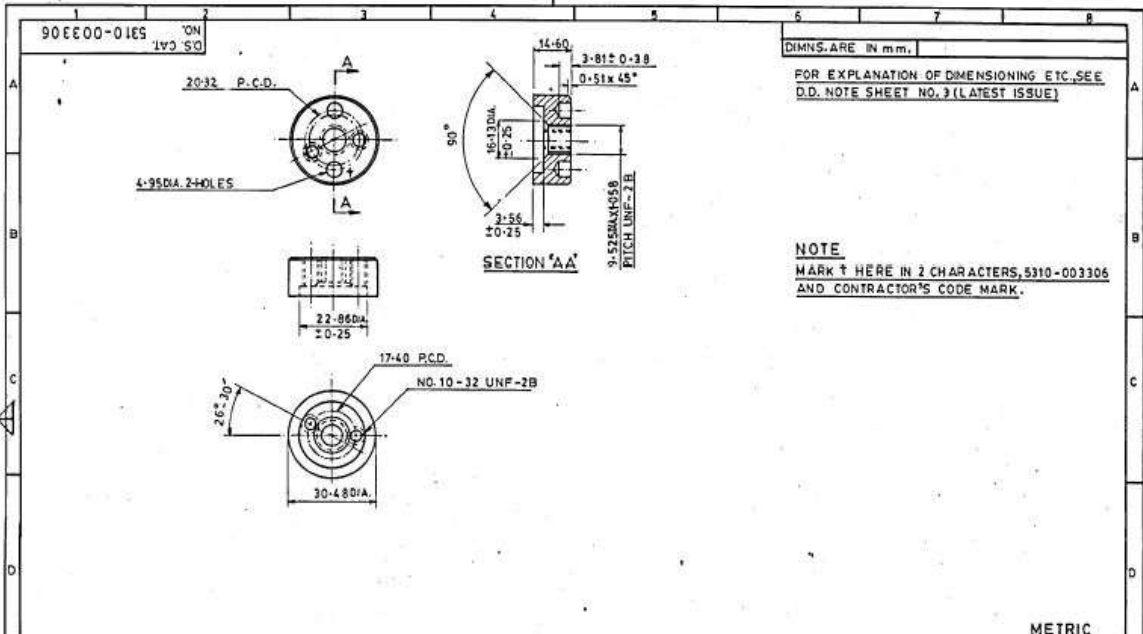

DIMNS. ARE IN mm.
FOR EXPLANATION OF DIMENSIONING ETC. SEE
D.D. NOTE SHEET NO. 3 (LATEST ISSUE)

NOTE
MARK † HERE IN 2 CHARACTERS, 5310-003306
AND CONTRACTOR'S CODE MARK.

METRIC

DRN.	CHD.	TRD.	COMP.	AHSP	COA(SA),	ICHAPUR
SCALE :- 1:1		EST. MASS :- 52.5 GRAMS		APPROVED	DT. 10.12.69.	
DT. 28.4.98	<i>Aruls</i>	1/C;D;D	NEG. RE-TRACED	ASSY.	1005-000467 + 1005-100074	1005-000476
		MATERIAL :-	BS:970 PT.1: 1983 Gr. 709 M40 OR 605 M36 T-CONDITION	DGNP'S	CISA 179/23/1	
DATE	AUTHY.	BRIEF RECORD	ZONE	1/C;D;D	G.O.	H.T/HARDNESS :-
SEALED :-	DC.NO.17733-SA,	DT. 26.10.83			SIGN.	
NOMENCLATURE :-			NUT CLAMPING LEVER			
PROTECTIVE FINISH :-			PHOSPHATED TO SPECN. J55:0465-01-1988 CLASS II (ACCELERATED), OIL FINISH.			
DRG. NO.			5310-003306			
D.S.CAT. NO.			5310-003306			

98 Q 220-0155

FOR EXPLANATION OF DIMENSIONING ETC. SEE DRAWING SHEET NO. 1 FIRST ISSUE
 UNITS: DIMS. ARE IN IN. & MM.

MARK 'T' HERE IN 2 CHARACTER'S
 1005-000703 AND CONTRACTOR'S
 CODE MARK.

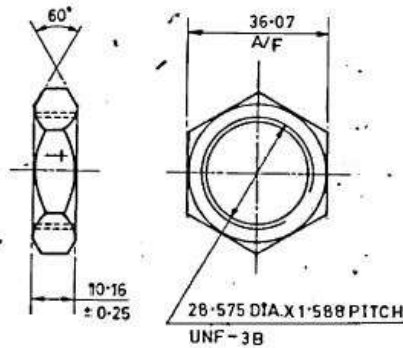

21.5.1001 25014-SA	DS. CAT. NO. 5310-022386 WAS 1005-000703	DATE	AUTHY.	SEALING: D.C. No. 1723-SA, DT. 22.10.83.	DRN.	CHD.	TRD.	COMP.	AHSP.	COA(SA)ICHAUR
19-10-99	24552-SA	19861-SA, 19899-SA, 21743-SA,	19861-SA, 19899-SA, 21743-SA,	PROFORMA CHANGED, NEG. RE-TRACED AND RE-SEALED.	19861-SA, 19899-SA, 21743-SA,	19861-SA, 19899-SA, 21743-SA,	19861-SA, 19899-SA, 21743-SA,	19861-SA, 19899-SA, 21743-SA,	19861-SA, 19899-SA, 21743-SA,	19861-SA, 19899-SA, 21743-SA,
BRIEF RECORD										
SCALE: 1:1										
MATERIAL: BS970 Pt. 1: 1983 GR. 703 M 40 OR 605										
M 38 CONDITION '1'										
H1/HARDNESS.										
PROTECTIVE FINISH: PHOSPHATE TO SPECN. JSS: 0465-01: 1988 CLASS II (ACCELERATED), OIL FINISH										
NOMENCLATURE NUT PLAIN PRECISION										
D.S. CAT. No. 5310-022386										

475100-5185

ON DIMS. ARE IN MM.

FOR EXPLANATION OF DIMENSIONING ETC. SEE D.D.
NOTE SHEET NO. 3 LATEST ISSUE.

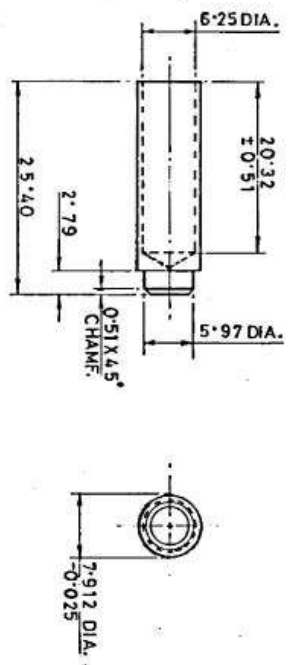

METRIC

25.03.2003	25703-SA	6.25 DIA. WAS 5.25 DIA.	B/I.	<i>MD</i>	DATE
11-6-96	23554-SA	PROFORMA CHANGED, NEG. RE-TRACED & DRG. RE-SEALED.		<i>MD</i>	DATE
		PREVIOUS D.C. NOS. 1983-SA, 1987-SA, 1991-SA, 1993-SA, 1997-SA, 2001-SA, 2003-SA.		<i>MD</i>	DATE
		BRIEF RECORD		<i>MD</i>	DATE
		SEALED:-D.C. 17737-SA, DT. 31.10.83.		<i>MD</i>	DATE
		DRN. CHD. TRD. SHOWED COMP. <i>MD</i>		<i>MD</i>	DATE
		SCALE: 2:1.		<i>MD</i>	DATE
		EST. MASS. 3.5 GRAMS.		<i>MD</i>	DATE
		APPROVED. DT. 10.12.69.		<i>MD</i>	DATE
		NEG. RE-TRACED		<i>MD</i>	DATE
		DT. <i>MD</i>		<i>MD</i>	DATE
		I/C D.O.		<i>MD</i>	DATE
		MATERIAL BS 970 PT. 3:1991 Gr. 080 M40 OR 070 M 55.		<i>MD</i>	DATE
		HT./HARDNESS.		<i>MD</i>	DATE
		PROTECTIVE PHOSPHATE TO SPECN. J55:0465-FINISH. 01:1988 CLASS-II OIL FINISH.		<i>MD</i>	DATE
		NOMENCLATURE PIN SHOULDER HEADLESS		<i>MD</i>	DATE
		DRG. NO.		<i>MD</i>	DATE
		DSCAT. NO. 5315-001544		<i>MD</i>	DATE

4 3 2 1

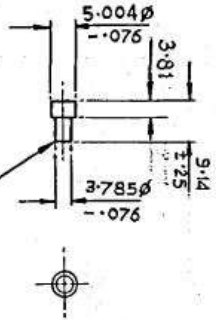

END TO BE RIVETED
AND FILED FLUSH ON ASSEMBLY

MATL:-
B5 970 Pt.1:1983 G-070 M 20 OR
ATA CL II BRIGHT DRAWN.

PROTECTIVE FINISH:-
PHOSPHATE TO SPEC. W/PN/GEN/3 CLASS
II OIL FINISH. (LATEST ISSUE)

9.2.89	20132	CL. WEA. PREPARED DWS. RE-SEALED	PKS SSO
		PREVIOUS EXT. NO. 1993-5418352-51, COPY 17733-5418352-51, COPY	
AUTHY. DATE	ZONE	BRIEF RECORD	SIG.
FOR EXPLANATION OF DIMENSIONING ETC.			
SEE DD NOTE SHEETS 3 LATEST ISSUE.			
ESTIMATED WEIGHT- ON ASSY		OR 1.8.89 16:10 SCALE:- 1:1 SEALED: DC(0)17738-SA DT. 1-1-83	
		ASSY. DRG. 1005-000657	COA(SA) CHAPUR
		MATERIALS AS STATED.	METRIC
		DIMENSIONS ARE IN MILLIMETRES	
		APPROVED: 10/12/89 (CLNEG. PREPARED)	
		DESIGNER'S REF: CISA.179/18/1	
		DS. CAT. NO. 5315-001547	
		PIN, STOP	

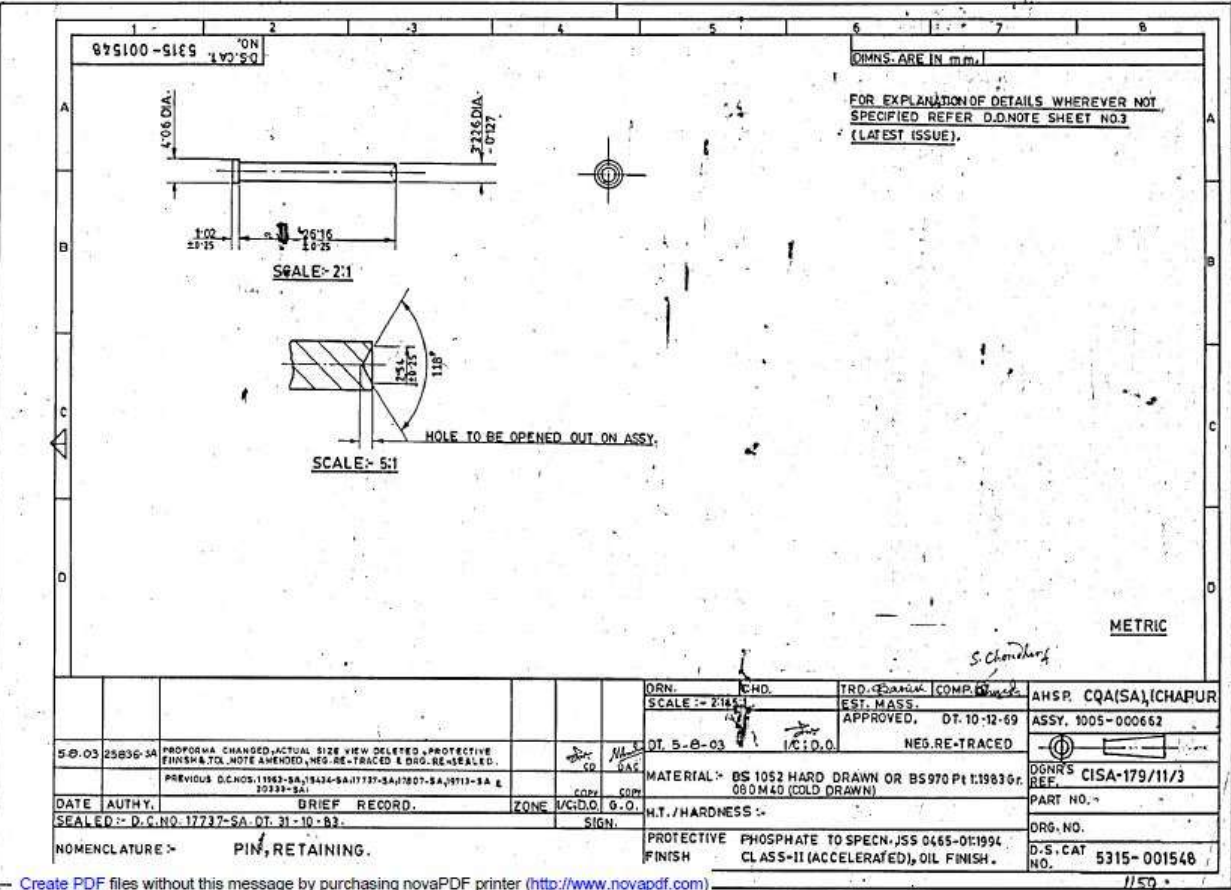

FOR EXPLANATION OF DETAILS WHEREVER NOT SPECIFIED REFER D.D. NOTE SHEET NO.3 (LATEST ISSUE).

METRIC

ORN.		COND.	TRD. Q.	COMP.	APPROVED.	DT.	AHSP. CQA(SA), ICHAPUR
SCALE :- 2:1					EST. MASS.	10-12-69	ASSY. 1005-000662
DT. 5-8-03				NEG. RE-TRACED			
MATERIAL :- BS 1052 HARD DRAWN OR BS 970 Pt 1: 1983 or 080 M40 (COLD DRAWN)							DGNR'S REF. CISA-179/11/3
DATE AUTHY.		BRIEF RECORD.		ZONE		P.A.R.T. NO.	
SEALED :- D.C. NO. 17737-SA-OT. 31-10-83.		SIGN.		H.T./HARDNESS :-		DRG. NO.	
NOMENCLATURE :- PIN, RETAINING.		PROTECTIVE PHOSPHATE TO SPECN. JSS 0465-01:1994		FINISH CLASS-II (ACCELERATED), OIL FINISH.		D.S. CAT NO. 5315-001548	

675100-515

ON I.V.C.S.D. DIMNS. ARE IN mm

FOR EXPLANATION OF DETAILS WHEREVER NOT SPECIFIED, REFER D.D.NOTE SHEET NO 3.(LATEST ISSUE)

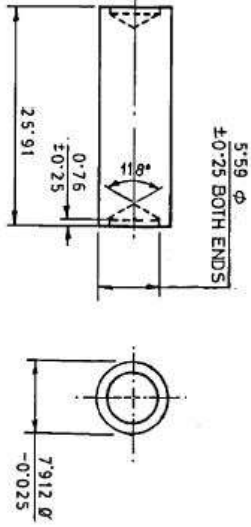

13-04-06	26/100	PROFORMA CHANGED TO NOTE AMENDED, NE G. RE-TRACED AND DRG. RE-SEALED.			
	SA	PREVIOUS D.C.NOS. 11903-5AJ5357-5A19285-5A, 16318-5A, 17238-5A822070-5A			
DATE	AUTHY.	BRIEF RECORD	ZONE	I/C: D.O.	G.O.
		SEALED:-DC,NB,17738-SA,DT,11,83.			
DRN.	CHD.	TRD. 4P			
SCALE:-	2:1	EST. MASS:- 9 GRAMS			
DT. 13-04-06	I/C: D.O.	APPROVED DT. 10-12-69			
		(NEG. RE-TRACED)			
MATERIAL:- BS 970 P1.1: 1983 Gr. 6.37 M 17		DGNR'S CISA 179/24/2			
H/T HARDNESS:- CASE HARDENED TO A DEPTH OF 0.20		PART NO.			
PROTECTIVE FINISH:-		DRG. NO.			
NOMENCLATURE:- PIN RETAINING STUD		D.S. CAT. NO. 5315-001549			

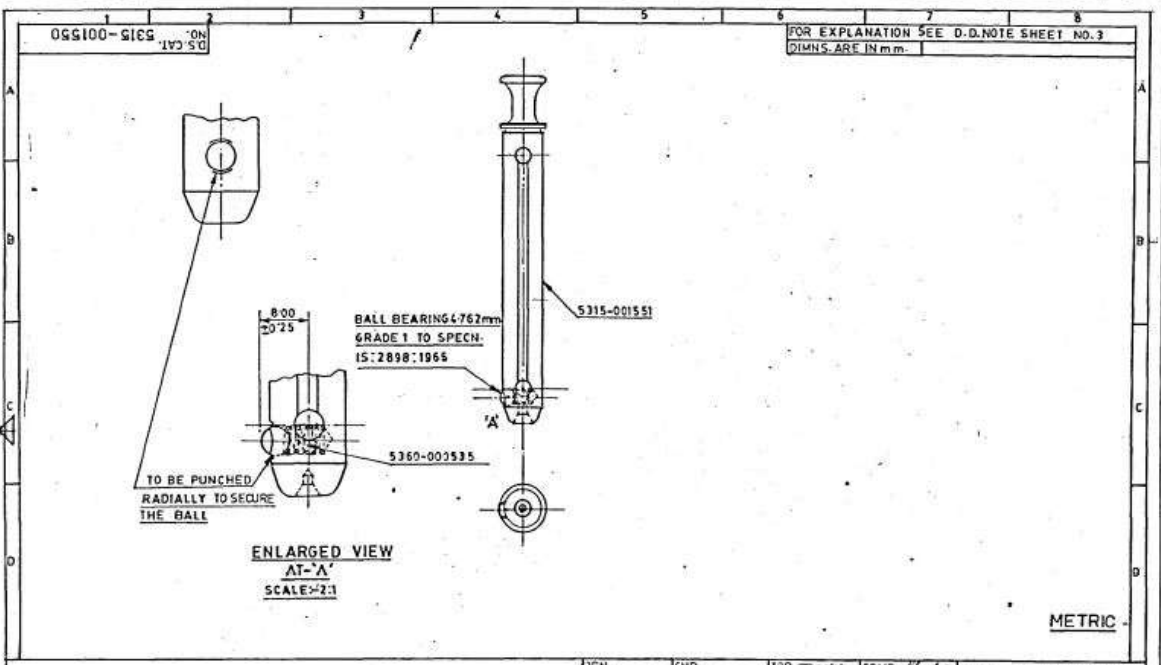

D.S. CAT. NO. 005100-315		FOR EXPLANATION SEE D.D. NOTE SHEET NO. 3 DIMNS. ARE IN mm.	
2103.99		24526-5A	PROFORMA CHANGED, NEG. RE-TRACED & ORG. RE-SEALED.
DATE AUTH.		BRIEF RECORD	
SEALED:-		D.C. NO. 17731-5A, DT. 22-10-63	
NOMENCLATURE		PIN, FRONT, MOUNTING ASSEMBLY	
DRN.	CHD.	TRD. CP. PLAN. & COMP. <i>Handwritten</i>	AHSP CQA(SA), ICHAPUR
SCALE: 1:1 & 2:1	EST. MASS:- 110 Grams	APPROVED DT. 10-12-69	ASSY. 1005-000678
DI. 21-9-69	VC D.O.	NEG. RE-TRACED	
MATERIAL :-		DGR'S REF. CISA 179/27	
ZON. VC. D.O. G.O.		PART No.	
HARDNESS		ORG. No.	
PROTECTIVE FINISH.		D.S. CAT. No. 5315-001550	

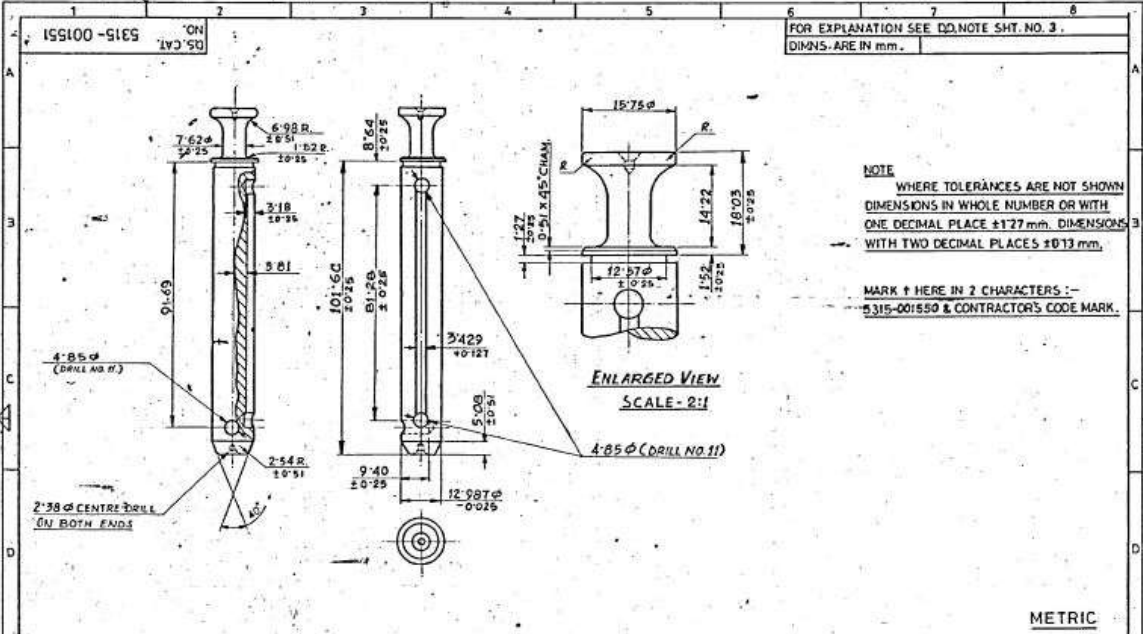

DRN.		CHD.	TRD.	COMP.	AHSP.
SCALE :-		1 : 1	EST. MASS	APPROVED	DT 10-12-69
DT 8-6-99		1/C DD	APPROVED	NEG RE-TRACED	ASST. 5315-001550
08-6-99	24390-SA	PROFORMA CHANGED, PROTECTIVE FINISH AMENDED. NEG. RE-TRACED AND DRG. RE-SEALED.	PREVIOUS DC No. 11943-SA, 14935-SA, 15359-SA, 17771-SA, 17739-SA, 17822-SA & 19878-SA.	BRIEF RECORD	ZONE
DATE	AUTHY.	ZONE	1/C, DD	QC	HI/HARDNESS
SEALED:-	D.C. 17739-SA, DT. 3.11.83	SIGN.	PROTECTIVE FINISH:-	PHOSPHATE TO SPECN. J55:0465-01:1988 CLASS II (ACCELERATED), OIL FINISH	PART NO.
NOMENCLATURE :-		PIN, FRONT MOUNTING		DRG. NO.	5315-001551

4 3 2 1

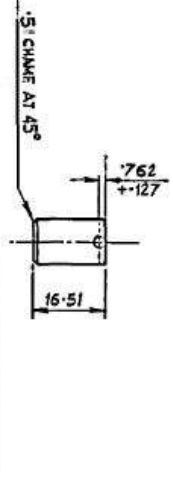

TWIST DRILL 1:10 15:5101HS.
 0.964 ± 0.025
 -0.025

PROTECTIVE FINISH:-
 PHOSPHATE TO SPECN WPW/GEN/3
 CLASS II OIL FINISH.

MATERIAL:-
 BS 970 P1.1:1983 Gr 709M40
 OR 605 M 36 CONDITION T

ESTIMATED WEIGHT: 11.5 GRAMS.

26439 SA	17685	1005-006863 400 ASSEMBLY	Int'l
20333 -SA	28289	CL NEG. RETRACED DR. DRAWING RE-SEALED.	Int'l
		PREVIOUS DC(I) NO. 11963-SA, 18359-SA 16285-SA, 17724-SA	LEGAL
		COPY	
AUTHY	DATE ZONE	BRIEF RECORD	SIG.
FOR EXPLANATION OF DIMENSIONING ETC., SEE D.D. NOTE SHEET NO.3 LATEST ISSUE.			
Q.N.	DATE	NAME	
DRN.			
TRD.	92.69	QUAN	
COMPT	9.2.81		
DR. 2.8.69	ICP	D.O.	
SCALE: 1:1			
SEALED: DC(I)			
17724-SA			
DT/26/10/83			
ASSY. DRG.:	1005-006863	COA(SA)ICHPUR	
MATERIAL:-	AS STATED		
DIMENSIONS ARE IN MILLIMETRES			
PIN, STRAIGHT,		HEADLESS	
DESIGNER'S REF		CISA179/28/1	
D.S. CAT. NO.		5315-001552	
APPROVED: DT/10/12/69. (CL NEG. RETRACED)			

REGIONS 1-4 1:2000-1:1000 5-8 1:500-1:250 9-12 1:250-1:125 13-16 1:125-1:62.5 17-20 1:62.5-1:31.25 21-24 1:31.25-1:15.625 25-28 1:15.625-1:7.8125 29-32 1:7.8125-1:3.90625 33-36 1:3.90625-1:1.953125 37-40 1:1.953125-1:0.9765625 41-44 1:0.9765625-1:0.48828125 45-48 1:0.48828125-1:0.244140625 49-52 1:0.244140625-1:0.1220703125 53-56 1:0.1220703125-1:0.06103515625 57-60 1:0.06103515625-1:0.030517578125 61-64 1:0.030517578125-1:0.0152587890625 65-68 1:0.0152587890625-1:0.00762939453125 69-72 1:0.00762939453125-1:0.003814697265625 73-76 1:0.003814697265625-1:0.0019073486328125 77-80 1:0.0019073486328125-1:0.00095367431640625 81-84 1:0.00095367431640625-1:0.000476837158203125 85-88 1:0.000476837158203125-1:0.0002384185791015625 89-92 1:0.0002384185791015625-1:0.00011920928955078125 93-96 1:0.00011920928955078125-1:0.000059604644775390625 97-100 1:0.000059604644775390625-1:0.0000298023223876953125

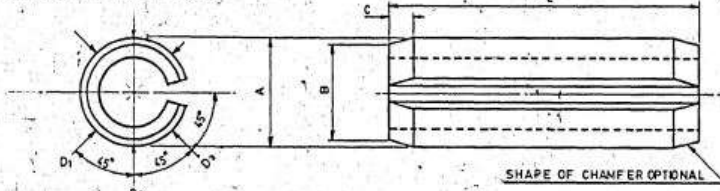

DIMNS. ARE IN mm.

NOTE:-
 TOLERANCE ON LENGTH #38
 * THIS DIMENSION FOR REFERENCE ONLY.
 MATL:- BS.1449 Pt.1:1972 Gr.CS.95 SEC.C
 ALT. MATL:- BS.970 Pt.1:1972 G.060 A96.
 SPECIMEN NOMENCLATURE:-
 PIN, SPRING, STEEL, PHOSPHATED (OILED)
 FINISH 1.98 DIA X 12.70 LONG
 D.S.CAT. NO. 5315-002077.

NOMINAL PIN DIAMETER		1.98	2.39	3.18	3.96
A DIA OF PIN (GO RING GAUGE)	MAX.	2.184	2.616	3.429	4.242
	MIN.	2.108	2.515	3.327	4.115
B	MAX.	1.90	2.31	3.10	3.84
	NOM.	0.36	0.46	0.61	0.71
C	MAX.	0.46	0.56	0.71	0.81
	NOM.	0.36	0.46	0.61	0.71
STOCK THICKNESS		0.46	0.56	0.71	0.81
RECOMMENDED HOLE SIZE	MAX.	2.057	2.464	3.277	4.064
	MIN.	1.98	2.388	3.175	3.962
DOUBLE SHEAR STRENGTH	KG. MIN.	295	454	953	1361

L' LENGTH	D.S. CAT. NO./ORDNANCE	PART NUMBER.
12.70	5315-002077	5315-002072
14.29		5315-002070
19.05		586068
23.81		5315-002050
28.57		5315-002051

METRIC

DRN.	CHD.	TRD. 225	COMP. 21/2	AHSP	CQA(SA)-ICHAPUR
SCALE:- NOT TO SCALE.	EST. MASS:-	APPROVED. DI.	(NEG. RE-TRACED)	ASSY.	
DT. 25-1-2003	1/C: D.O.				
MATERIAL:- AS STATED				DGN'S REF.	PART OF BF 5X21
DATE AUTHY. BRIEF RECORD.	ZONE	COPY.	COPY.	PART. NO.	
SEALED:- DCNO. 15049-SA QT. 74.2.77	STGN.			DRG. NO.	
NOMENCLATURE :- PIN. SPRING.				D.S. CAT. 5315-002050-5315-002051	
				NO. 5315-002050-5315-002051	
				5315-002051-5315-002051	

569510-07ES
 ON
 20 S G

FOR EXPLANATION SEE G.D. NOTE SHEET No.3
 DIMS ARE IN mm.

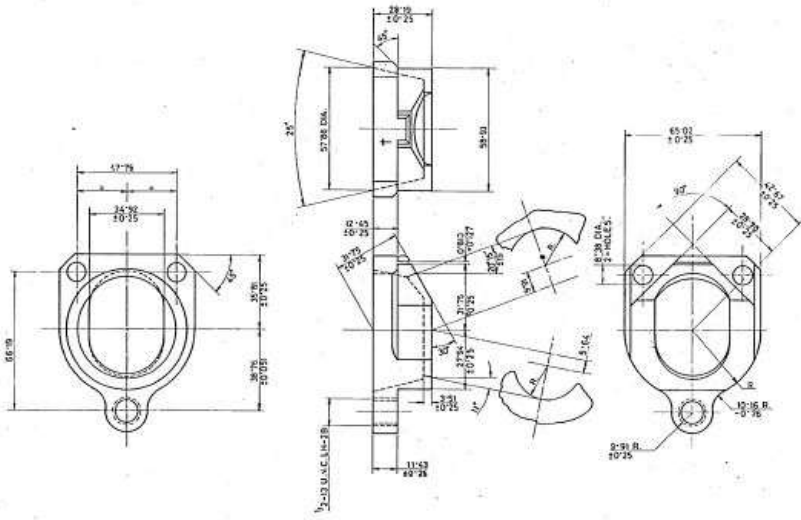

NOTE -
 WHERE TOLERANCES ARE NOT SHOWN
 DIMENSIONS IN WHOLE NUMBER OR WITH
 ONE DECIMAL PLACE 1/127mm
 DIMENSIONS WITH TWO DECIMAL PLACES 1/101mm
 MARK † HERE IN 2-CHARACTER S.
 5340-2655 AND CONTRACTOR'S CODE MARK

										METRIC	
DRILL	END	TRD	S.K.P	COMP	2/2	GAZE	AHSP	COA(SA),	ICHAPUR		
SCALE	1:1	EST	1455-	230	GAZE		APPROVED	01.10.12.69	ASSY.	1005-000628	
							REQ.	RETRACTED			
DT.	11.3.2008						IC: D.O.				
MATERIAL	BS 570 P1.1.1983 Gx703 M40 CONDITION T.										
DATE	AUTHY	BREF	RECORD	ZONE	IC: D.O.	G.O.					
SEALED	B.C. No. 1031-54, 27.02.69										
NOMENCLATURE							CLAMP PIVOT			PROTECTIVE FINISH	
							PHOSPHATE 10 SPECN.			ASS-0455-01.0568 CLASS II(ACCELERATED) DS. FINISH	
										CORP'S SECT. CISA 179/13/2	
										D.S. CAT. No. 5340-015695	

969510-0165 DRN
182259

FOR EXPLANATION SEE D.D. NOTE SHEET NO. 3
(DIMNS. ARE IN MM.)

MARK T HERE IN 3 CHARACTERS :-
5340-015696 AND CONTRACTOR'S CODE MARK.

FOR FINISH DIMENSIONS SEE ASSY.
D.S. CAT. NO. 1005-000622

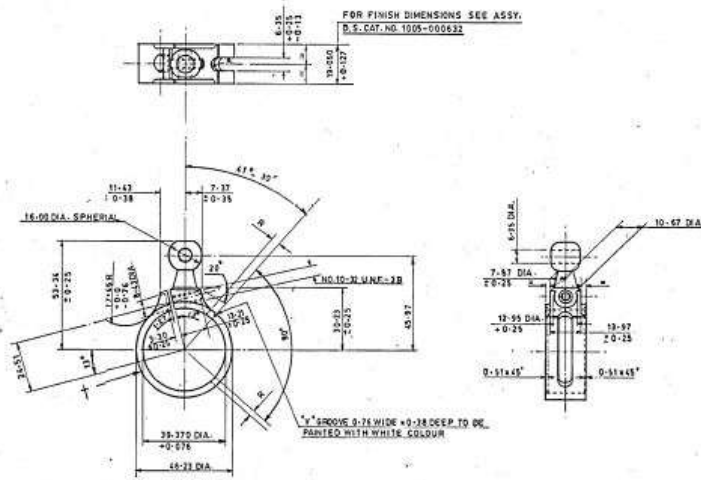

METRIC

DRN.	CHD.	FRD. W/444P.	CONR. //	ANSP. CGA(SA) (CHAPUR)
SCALE 1:1	EST. MASS. 86 GRAMS	APPROVED DT. 10.12.59	ASSY. 1005-000622	
DT. 29.8.1959	NEG. RE-TRACED			
MATERIAL BS:2100 11974 G. B72 OR FORGED TO BS:205 P.1:1953 G. 705 HAD CONDITION S OR T				OWNERS REF. CISA 179/45
DATE AUTH. BRIEF RECORD	ZONE	U/C/D	H.7/MARCHNESS	PART NO.
SEALED DT. 02.02.1959. G.A. DT. 31.10.59				DRG. NO.
NOMENCLATURE HOUSING ELEVATING GEAR			PROTECTIVE FINISH PHOSPHATE TO SPECN. J551045-011888 CLASS 11(ACCELERATED)OIL FINISH	D.S. CAT. NO. 5340-015696

265000-0965

ON DIMS. ARE IN mm.

FOR EXPLANATION OF DETAILS WHEREVER NOT SPECIFIED REFER D.D. NOTE SHEET NO. 3 (LATEST ISSUE)

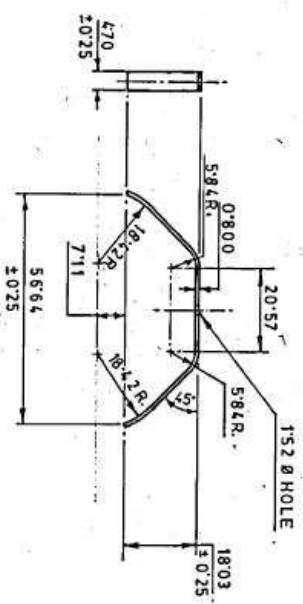

METRIC

1/5-5-06	PROGRAM CHANGED FOR NOTE & PROTECTIVE FINISH		
DATE	AUTHY.	PREVIOUS D.C. NOS. 1793-SADT 26, 10, 83 AND 1773-SA	
DATE	AUTHY.	BRIEF RECORD	
SEALD:	D.C. NO. 1773-SADT 26, 10, 83		
DRN.	CHD.		
SCALE:	1:1	EST. MASS: 2 GRAMS	AHSP CQ(A(SA)) CHAPUR
DT.	APPROVED	DI: 10.12.89	ASSY. 1005-000628
		(NEG. RE-TRACED)	
MATERIAL: BS 149EN 42F OR EN 42 G			
H.T./HARDNESS: HRD. & TEMP. 400-450 HV			
PROTECTIVE PHOSPHATE TO SPECN. JSS-0465-01:1994			
FINISH: CLASS II (ACCELERATED) OIL FINISH.			
NOMENCLATURE: SPRING LEAF BENT.			
D.S. CAT. NO.	3360-000532		

17-5-06

17-5-06

17-5-06

17-5-06

FOR EXPLANATION OF DETAILS WHEREVER NOT SPECIFIED, REFER DD NOTE SHEET NO.3 (LATEST ISSUE)

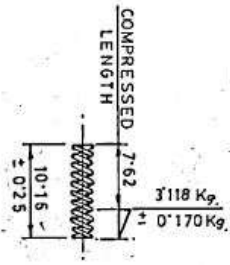

DIA. OF WIRE — 0.610 mm (23 SWG)
 OUT SIDE DIA. OF SPRING — 2.90 DIA. ± 0.13

TOTAL NO. OF COILS — 11 ± 1/2
 ONE COIL AT EACH END TO BE CLOSED IN GROUND SQUARE TO THE AXIS OF SPRING. LEAVING 3/4 OF A COIL NON EFFECTIVE AT EACH END.

SPRING SHOULD WORK FREELY IN A BORE OF 3.18 DIA.
 SPRING TO BE COMPRESSED TO A LENGTH OF 7.37 FOR 12 HOURS IMMEDIATELY BEFORE GAUGING.

17-5-06	26201-SA	PROGRAM CHANGED, TOL. NOTE AMENDED, PROTECTIVE FINISH SPECN. ADVANCED. NEG. RETRACTED AND DRG. RE-SEALED.					
DATE	AUTHY.	PREVIOUS: D.C. No. 1743-SA, 1735-SA, 1736-SA, 1738-SA					
DATE	AUTHY.	BRIEF RECORD					
SEALING	D.C. NO. 1738-SA, D.I. 1183.	TRD. <i>[Signature]</i>	COMP. <i>[Signature]</i>				
SCALE	1:1	EST. MASS: —	DT: 10.12.69				
DT: 17-5-06		I/CDO. (NEG. RETRACTED)					
D	MATERIAL: — BS.5216:1975 M5 OR ND3						
H.T./HARDNESS: —							
PROTECTIVE FINISH: —	PHOSPHATE TO SPECN.JSS:0465-Q1:1994						
NOMENCLATURE: —	CLASS II (ACCELERATED), OIL FINISH.						
	SPRING HELICAL COMPRESSION						

535000-0935 1.73 S.D. DIMNS. ARE IN mm.

FOR EXPLANATION OF DETAILS WHEREVER NOT SPECIFIED, REFER DD NOTE SHEET NO.3 (LATEST ISSUE)

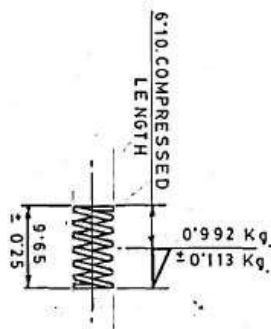

DIA. OF WIRE = 0.550
 OUT SIDE DIA. OF SPRING 4.57 ± 0.13
 TOTAL NO. OF COILS = 7 ± 1/2
 ONE COIL AT EACH END TO BE CLOSED IN GROUND SQUARE TO THE AXIS OF THE SPRING. LEAVING 3/4 OF A COIL NON-EFFECTIVE AT EACH END. SPRING SHOULD WORK FREELY IN A BORE OF 4.83 DIA. SPRING TO BE COMPRESSED TO A LENGTH OF 4.83 FOR 12 HOURS IMMEDIATELY BEFORE GAUGING.

METRIC

17-5-06 126201-SA		FORMERLY CHANGED, TOL. NOTE AND PROTECTIVE FINISH AMENDED. NEG. RE-TRACED & ORG. RE-SEALED.		PREVIOUS D.C. NOS. 11883-SA, 13398-SA, 17739-SA AND 17938-SA	
DATE	AUTHY.	BRIEF RECORD		C.D.	M.S.D.
DRN.	CHD.	TRD.	COMP.	COPY	COPY
SCALE: 2:1	DT: 10.12.59	EST. MASS: ---	APPROVED	1/C/D/D.	G.O.
DT: 17-5-06	(NEG. RE-TRACED)	ASSY. 1005-000688			
MATERIAL: BS 5215:1975 M 5 OR ND3		DGNR'S REF. CISA-179/27/2			
H.T./HARDNESS: ---		PROSPHATE TO SPECN. JSS: 0465-01:1994			
FINISH: ---		CLASS III (ACCELERATED), OIL FINISH.			
NOMENCLATURE: SPRING, BALL BEARING		D.S. CAT. NO. 5360-000535			

9C5000-0935

ON 1/3/5/8 DIMNS. ARE IN mm.

FOR EXPLANATION OF DETAILS WHEREVER NOT SPECIFIED, REFER D.D. NOTE SHEET NO. 3. (LATEST ISSUE)

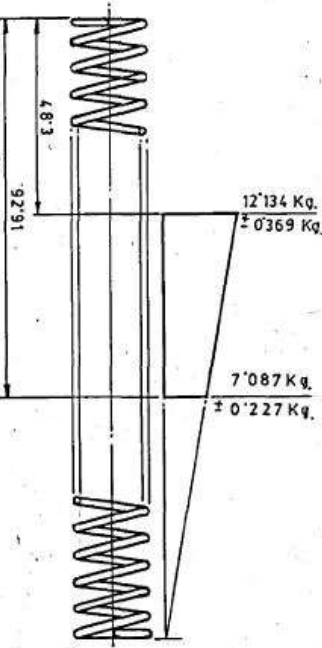

DIA. OF WIRE: — 1.829 (15 SWG)
 OUT SIDE DIA. OF SPRING: — 18.76 ± 0.20
 TOTAL NO. OF COILS: — 24 ± 1/2
 ONE COIL AT EACH END TO BE CLOSED IN GROUND SQUARE TO THE AXIS OF SPRING.
 LEAVING 3/4 OF A COIL NON-EFFECTIVE AT EACH END.
 SPRING SHOULD WORK FREELY INTS LOADED AND UNLOADED CONDITION IN A BORE 18.85 DIA. AND ON A ROD 14.30 DIA.
 SPRING TO BE COMPRESSED TO A LENGTH OF 45.72 FOR 24 HOURS.
 IMMEDIATELY BEFORE GAUGING.

METRIC

23-08-06	28204-5A	PROGRAMA CHANGED, TOL. NOTE AND PROTECTIVE FINISH AMENDED, NEG. RE-TRACED & DRG. RE-SEALED.						
		PREVIOUS D.C. NOS. 11983-5A, 1317-5A, 1771-5A, 1738-5A AND 1009-5A						
DATE	AUTHY	BRIEF RECORD						
DRN.	CHD.	TRD. / EST. MASS. / COMP. STAMP						
SCALE: — 1:1		APPROVED (NEG. RE-TRACED)	DI. 10.12.68					
DI. 23-05-06		MATERIAL: — BS 5216 : 1975 M5 OR ND3						
H.T/HARDNESS: —								
PROTECTIVE FINISH: —		PHOSPHATE TO SPECN.JSS 0465-01: 1994 CLASS II (ACCELERATED) OIL FINISH						
NOMENCLATURE: —		SPRING, HELICAL, COMPRESSION.						

435000-09C 5 1 2 3 4

ON DIMS ARE IN mm.

FOR EXPLANATION OF DETAILS WHEREVER NOT SPECIFIED, REFER DD, NOTE SHEET NO 3. (LATEST ISSUE)

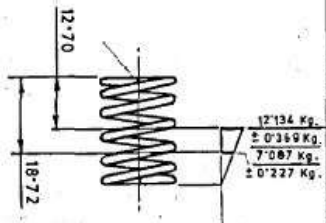

DIA. OF WIRE 193.
 OUT SIDE DIA. OF SPRING 18.74 ± 0.20.
 TOTAL NO. OF COILS:— 6 ± 1/2.
 ONE COIL AT EACH END TO BE CLOSED IN GROUND SQUARE TO THE AXIS OF THE SPRING LEAVING 3/4 OF A COIL NON-EFFECTIVE AT EACH END.
 SPRING SHOULD WORK FREELY IN ITS LOADED AND UNLOADED CONDITION IN A BORE 18.85 DIA. AND ON A ROD 14.30 DIA.
 SPRING TO BE COMPRESSED TO A LENGTH OF 12.45 FOR 24 HOURS.
 IMMEDIATELY BEFORE GAUGING.

METRIC

25-5-06	26205	PROFORMA CHANGED, TOL. NOTE, AND PROTECTIVE FINISH AMENDED, NEG-RE-TRACED & DRG-RE-SEALED. PREVIOUS D.C.NOS. 11853-5A/15377-5A/17724-5A/17828-5A AND 20439-5A							
DATE	AUTHY.	BRIEF RECORD	ZONE	W/C/D.O.	GO.	SIGN.			
SEALED:—	D.C.NO.17734 SA, DT. 26.10.83.								
DRN.	CHD.	TRD.	RE	COMP.					
SCALE:—	1:1	EST. MASS:							
DT. 25-5-06		APPROVED							
		W/C/D.O.							
MATERIAL:—	BS 5216:1975 M5 OR ND3								
H.T./HARDNESS:—									
PROTECTIVE FINISH	PHOSPHATE TO SPECN. JSS 0465-01:1994								
FINISH:—	CLASS II (ACCELERATED), OIL FINISH								
NOMENCLATURE:—	SPRING HELICAL, COMPRESSION								
D.S.CAT. NO.	5360-000537								

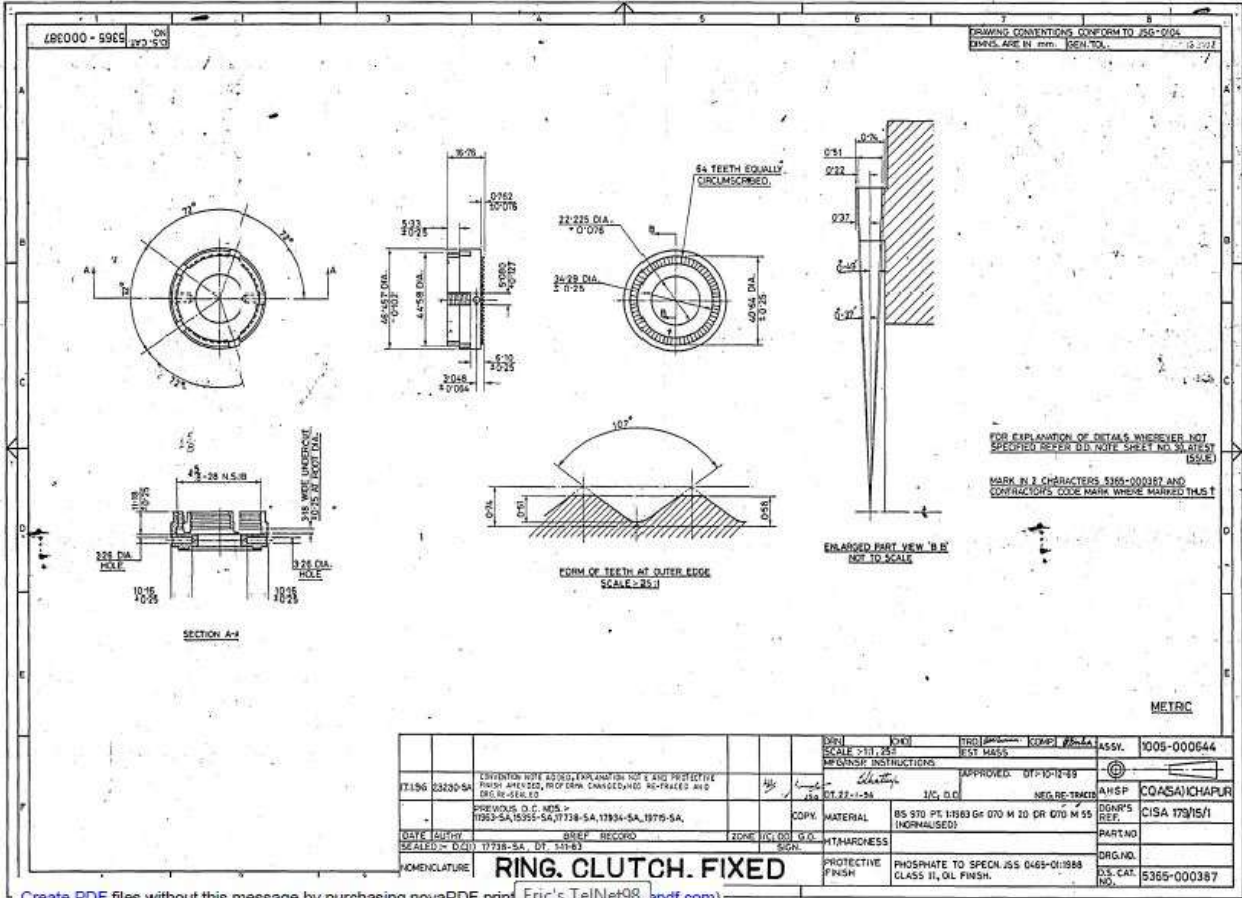

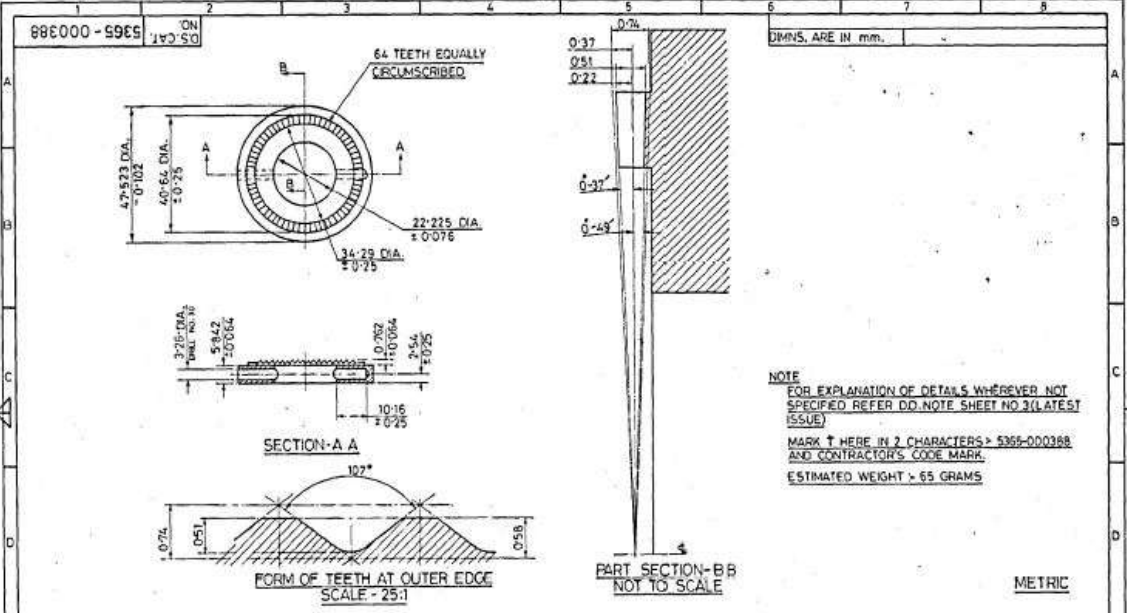

NOTE
 FOR EXPLANATION OF DETAILS WHEREVER NOT SPECIFIED REFER DD.NOTE SHEET NO 2(LATEST ISSUE)
 MARK ↑ HERE IN 2 CHARACTERS > 5365-000388 AND CONTRACTOR'S CODE MARK.
 ESTIMATED WEIGHT > 65 GRAMS

DYN [CND]		TRD <i>part</i>	COMP <i>Altraha</i>	ASSY	1005-000646
SCALE > 1:1 25:1		EST. MASS.			
MFG/INSP INSTRUCTIONS <i>Sliding</i>			APPROVED.	DT. 10-12-69.	
DT. 17-2-96		IC, D.O.	NEG RE-TRACED	A/HSP	CG(SA)CHAPUR
16-2-96 23261-SA	PROFORMA CHANGED, NEG. RE-TRACED & DRG. RE-SEALED.			OWNERS REF.	CISA 179/16/1
PREVIOUS D.C. NOS 11062-SA, 11205-SA, 0728-SA, 0751-SA, 0751-SA, 0751-SA, 21428-SA		MATERIAL	BS 970 PT 1:1983 Gr. 070 M 20 OR 070 M 55(NORMALISED)		PART NO.
DATE	AUTHY.	BRIEF RECORD	ZONE	IC, D.O.	S.D.
SEALED > D.C.(1)	17738-SA,	01-1-11-83	SIGN.	HIT/HARDNESS	
NOMENCLATURE		RING, CLUTCH SLIDING		PROTECTIVE FINISH	PHOSPHATE TO SPECN. J55-0465-01-1988 CLASS II OL FINSH.
				DRG. NO.	
				D.S. CAT. NO.	5365-000388

NOTE:-
 WHERE TOLERANCES ARE NOT SHOWN
 DIMENSIONS IN WHOLE NUMBER OR WITH
 ONE DECIMAL PLACE ± 0.27 mm.
 DIMENSIONS WITH TWO DECIMAL
 PLACES ± 0.13 mm.

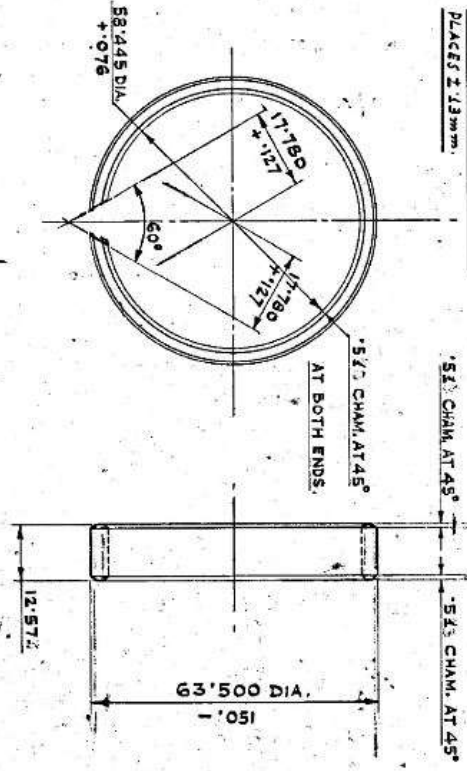

PROTECTIVE FINISH:-
 PHOSPHATE TO SPECN.JSS: 0465:01-1988 CLASS II (ACCELERATED)
 OIL FINISH.

MATERIAL:-
 SS1449P11:1983GT600RBS 970 PT.5:1972 Gr. 250 A58
 N.B. HEAT TREATMENT :- 400-460 HV

22029	SI1092	MATL. & PROTECTIVE FINISH AMENDED	Draft
17336-13.6	84	MATL. AMENDED	1/58
17336-13.6	84	DESIGN REVISIONS OR REVISIONS	1/58
17336-13.6	84	CANCELLED & DRAW SCHEDULE NUMBER 1450	1/58
5361-12017	9A	OSCATNO. ADDED.	1/58
108354	1274	DRG. SEALED AS A RECORD OR RECORD	1/58
AUTHY DATE ZONE		BRIEF RECORD	SIG.
FOR EXPLANATION SEE D.D. NOTE SHEET NO. 3		DGN.	NAME
DATE		DRN.	
TRD.		CHKD.	
COMP.		TRD.	
SCALE: 1/1		APP.:	
SEALD:- D.C.O. 1733-54 PT. 26/10/83		APPROVED:-	
ESTIMATED WEIGHT:- 45 GRAMS.		DESIGNER'S REF. FOR CISA	
RING EXPANDING		CISA. ICHAPUR	
		5365-000389	

METRIC

4

3

2

NOTE:-
 WHERE TOLERANCES ARE NOT SHOWN DIMENSIONS
 IN WHOLE NUMBER OR WITH ONE DECIMAL PLACE
 ± 1.27mm. DIMENSIONS WITH TWO DECIMAL
 PLACES ± 0.13mm.

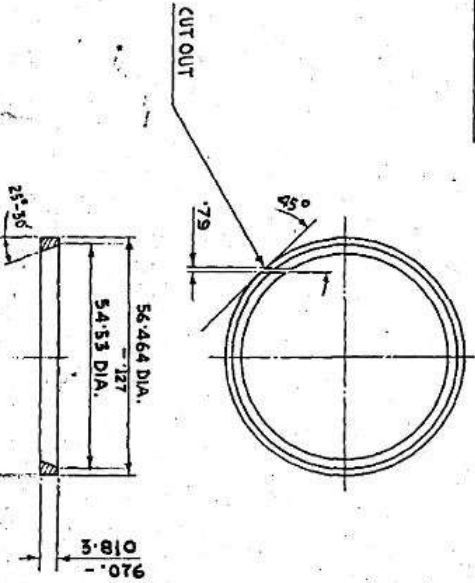

PROTECTIVE FINISH:-
 PHOSPHATE TO SPECN. W/PN/GEN/3 CLASS II, OIL FINISH.

MATERIAL:-
 B56323 P.T.L.:1982 DESIG. CF56 BK OR B5 970 PT.1:1983 GR.
 O80 M-40 (HEAT TREATED) OR CL. II NORMALISED.
 HARDNESS:- 250-300 H.V
 ESTIMATED WEIGHT:- 8 GRAMS.

FOR EXPLANATION SEE DD NOTE SHEET NO. 3

20194 Issues	CLOTHING PREPARED	DATE	NAME	ASSY.	1005-000528	CO(SA) KHAPUP
	REVISED			MATERIAL:- AS STATED		
	PREVIOUS DC/NO. SA-11863			DIMENSIONS ARE IN MILLIMETRES		
	SA-15315/5477334-8023449112			APPROVED. DT. 10-12-69.		
				(CL. NEG. RETEDED)		
				DESIGNER'S REF.		
				CISA 179/41		
				DS CAT. NO.		
				5365 - 000390		
				SCALE:- 1:1		
				SEALD:- DC (I)		
				17735-SA, DT. 28/10/83		
				RING SCRAPER		

26E000-99C5

STANDARD STRAIGHT KNURLS
20 TEETH IN 25.4 mm. OF
CIRCUMFERENCE.

DIMNS. ARE IN mm.
FOR EXPLANATION OF DIMENSIONING ETC SEE
D.O. NOTE SHEET NO.3 (LATEST ISSUE).

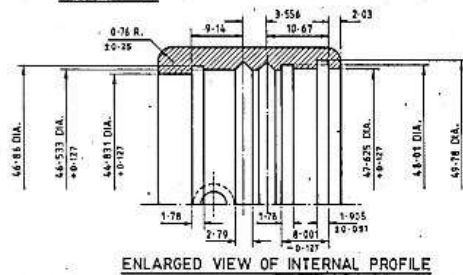
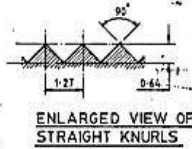
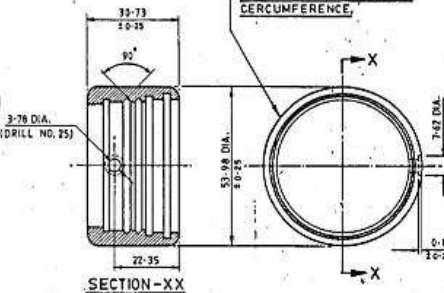

METRIC

24.12.2002		25631-SA		PROFORMA CHANGED, PROTECTIVE FINISH AMENDED, NEGATIVE RE-TRACED AND DRG. RE-SEALED.		DATE AUTHY. D.C. 17738-SA, DT. 1-11-83		BRIEF RECORD		ZONE		I/C/D.O. GO. SIGN.		H.T./HARDNESS:- HRD & TEMPERED 400 - 500 H.V.		PROTECTIVE FINISH:- PHOSPHATE TO SPECN. JSS 0465:01-1994 CLASS-II (ACCELERATED), OIL FINISH.		AHSP. CQA(SA), ICHAPUR		ASSY. 1005 - 000657		DGNR'S REF. CISA 179/18/2		PART NO.		DRG. NO.		D.S. CAT. NO. 5365 - 000392	
24.12.2002		25631-SA		PROFORMA CHANGED, PROTECTIVE FINISH AMENDED, NEGATIVE RE-TRACED AND DRG. RE-SEALED.		DATE AUTHY. D.C. 17738-SA, DT. 1-11-83		BRIEF RECORD		ZONE		I/C/D.O. GO. SIGN.		H.T./HARDNESS:- HRD & TEMPERED 400 - 500 H.V.		PROTECTIVE FINISH:- PHOSPHATE TO SPECN. JSS 0465:01-1994 CLASS-II (ACCELERATED), OIL FINISH.		AHSP. CQA(SA), ICHAPUR		ASSY. 1005 - 000657		DGNR'S REF. CISA 179/18/2		PART NO.		DRG. NO.		D.S. CAT. NO. 5365 - 000392	
24.12.2002		25631-SA		PROFORMA CHANGED, PROTECTIVE FINISH AMENDED, NEGATIVE RE-TRACED AND DRG. RE-SEALED.		DATE AUTHY. D.C. 17738-SA, DT. 1-11-83		BRIEF RECORD		ZONE		I/C/D.O. GO. SIGN.		H.T./HARDNESS:- HRD & TEMPERED 400 - 500 H.V.		PROTECTIVE FINISH:- PHOSPHATE TO SPECN. JSS 0465:01-1994 CLASS-II (ACCELERATED), OIL FINISH.		AHSP. CQA(SA), ICHAPUR		ASSY. 1005 - 000657		DGNR'S REF. CISA 179/18/2		PART NO.		DRG. NO.		D.S. CAT. NO. 5365 - 000392	

NOMENCLATURE:- RING

11E0

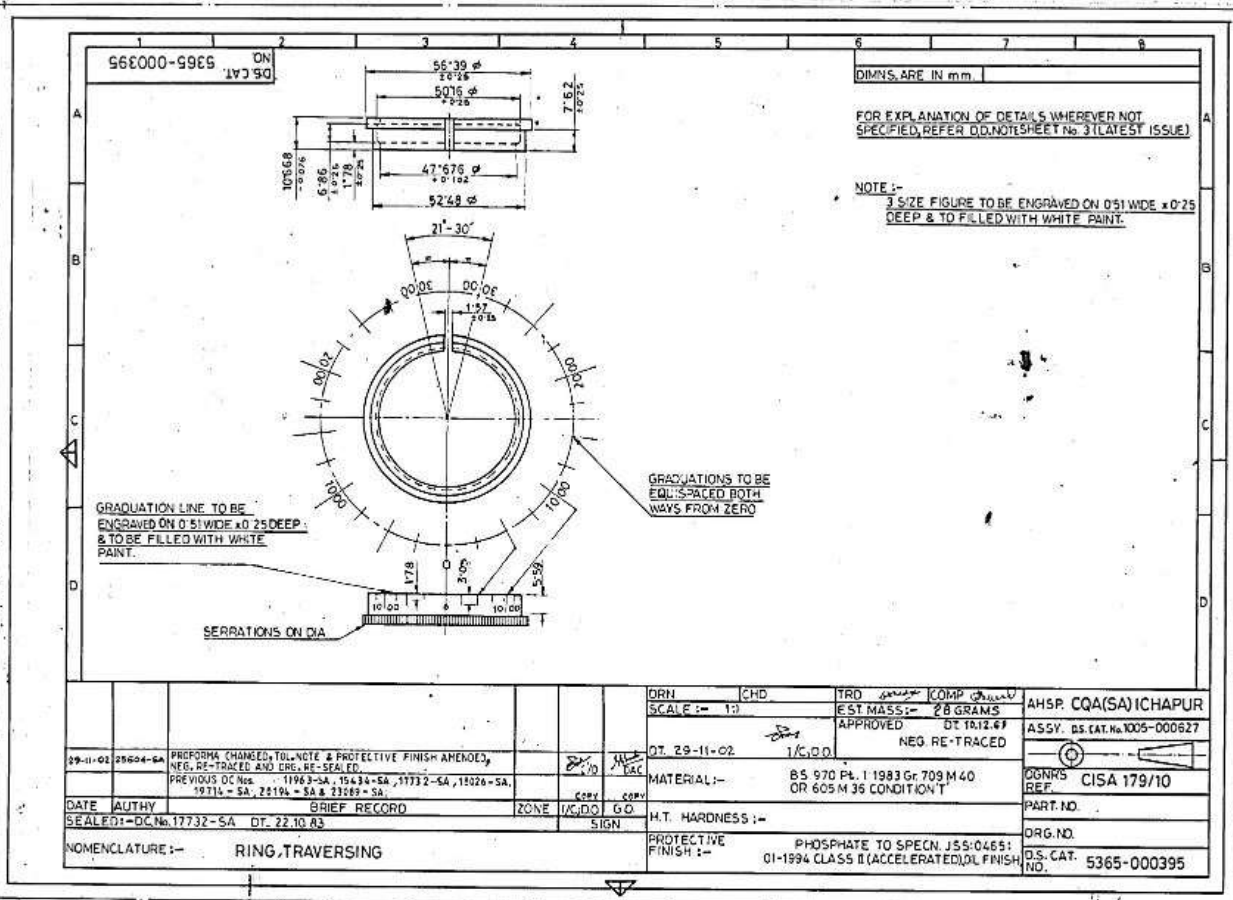

DRN	CHD	TRD	COMP	AHSP	CQA(SA) ICHAPUR
SCALE :- 1:1		EST. MASS :- 28 GRAMS	APPROVED DT. 10.12.07	ASSY. DS. CAT. No. 1005-000627	
DT. 29-11-02	1/6,0.0	NEG RE-TRACED			
29-11-02 25604-SA	PROFORMA CHANGED, TOL., NOTE & PROTECTIVE FINISH AMENDED, NEG. RE-TRACED AND ENG. RE-SEALED.				
	PREVIOUS DC Nos :- 1196-3-SA, 15434-SA, 11732-SA, 15026-SA, 19714-SA, 22194-SA & 23263-SA.				
DATE	AUTHY	BRIEF RECORD	ZONE	U/C, D.O	G.O.
SEALED :- DC No. 17732-SA	DT. 22.10.03				
NOMENCLATURE :- RING, TRAVERSING		M.T. HARDNESS :-		PROTECTIVE FINISH :-	
		PHOSPHATE TO SPECN. JSS-04651		01-1994 CLASS II (ACCELERATED) DL FINISH	
				ORG. NO.	
				D.S. CAT. NO. 5365-000395	

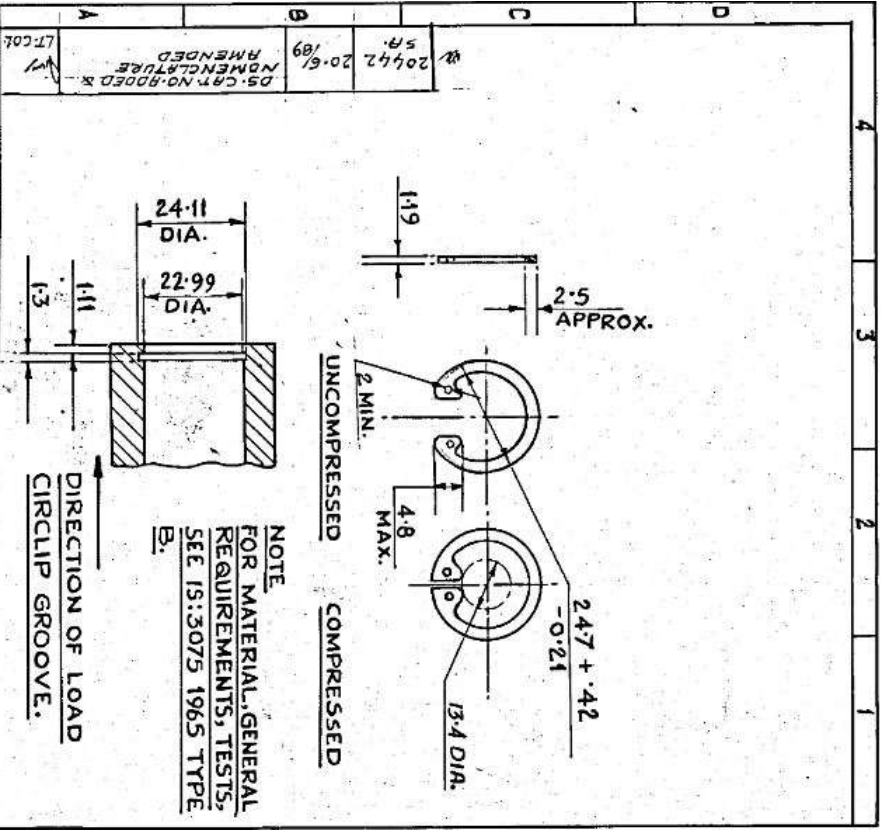

NOTE
FOR MATERIAL, GENERAL
REQUIREMENTS, TESTS,
SEE IS: 3075 1965 TYPE
B.

19407	5th. 86	19407	5th. 86	19407	5th. 86
SA		SA		SA	
AUTHY DATE		ZONE		SIG.	
DRAWING CON-		VENTIONS CON-		FORM TO IS: 696	
TOLERANCES FOR		UNTOLERANCED		DIMENSIONS SEE	
MEDIUM '15: 2002		SCALE: 1/1		SEALED: DCU/TZ4	
1005-000678/1005-00686		MATERIAL: S5 STATED		APPROVED: DT 6 9 80	
DIMENSIONS ARE IN:		MILLIMETRES		CL. NEG. PREPARED.	
RING RETAINING		STEEL - INT. 23mm.		DESIGNER'S REF	
CISA) ICHAPUR		CISA - 643		D.S. CAT. NO.	
5365 - 002039					

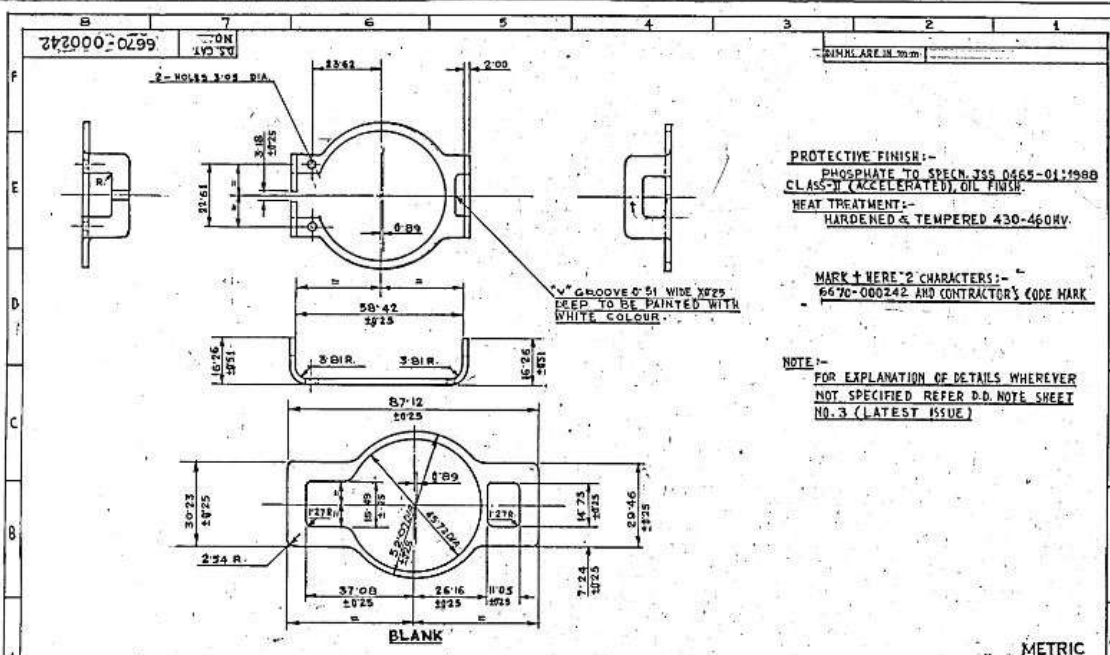

DGN	DRN	CHD.	TRD	A.BARK	COMP	A.G.	ASSY.	DRG. NO.	1005-000627
23462	17.8.98	D.S. CAT. NO. 6670-000242 WAS 1005-000677	1/K. DO	1/K. TECHDN	GAGE SCR		SCALE	1:1	
23814	20.1.95	PROTECTIVE FINISH AMENDED, NEG. RETRACED AND DRG. RE-SEALED	APPROVED		DCL		DGNR'S REF.	CISA-179/B	
		PREVIOUS D.C. NO. 2563-2475434 (A. 17733-1A. 18582-1A. BRIEF-RECORD	DT-10-12-69	NEG. RE-TRACED	EST. MASS	16 GRAMS	DET	SHTS	SHT.
AUTHY. DATE	ZONE				MATERIAL	DS-1449 PT. 1:1972 SEC. 5 G. 80 CS	DRG. NO./PART NO.		
SCALE	b.c (1) 17732-5A. DT. 22-10-83				H/T/HARDNESS	AS STATED	ANSP.	CQA(SA)CHAPUR	
NOMENCLATURE	INDICATOR TRAVERSING				PROTECTIVE FINISH		D.S. CAT. No.	6670-000242	