

DRG. INDIANISED BASED ON RUSSIAN ORIGINAL ISSUE - 17 AND DRG REPLACES ISSUE A VIDE 18th IRIGC POINT No. 2

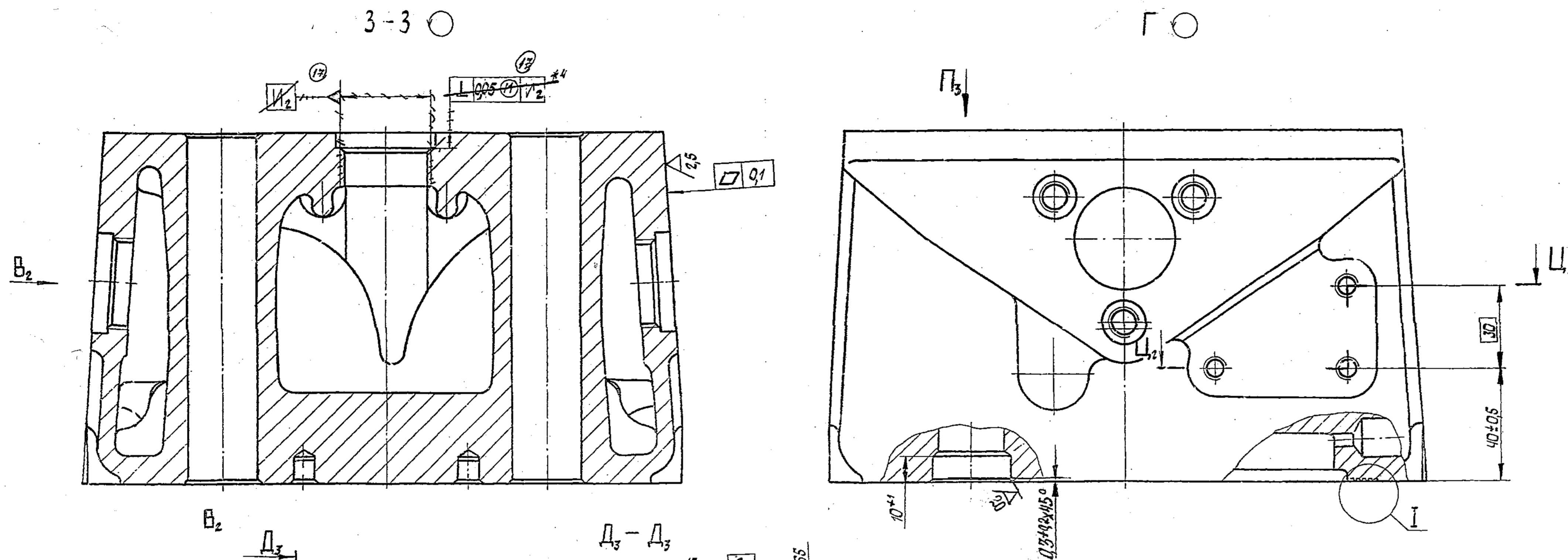

REDUCED ORIGINAL No. -1
R.H CYLINDER HEAD

1. NICKS, MARKS FLAY MARKS AND DIG OUT FROM MACHINING ARE NOT ALLOWED ON THE SURFACE M3.
2. SURFACE Y3 AND M3 SHOULD BE ON ONE FLATNESS.
3. *4 BASE AXIS OF NEAR DIAMETER.
3. OTHER GRAPHICS, DIMENSIONS, SURFACE FINISH MATERIAL AND TECHNICAL REQUIREMENTS ARE AS PER DRAWING 306-16-23.

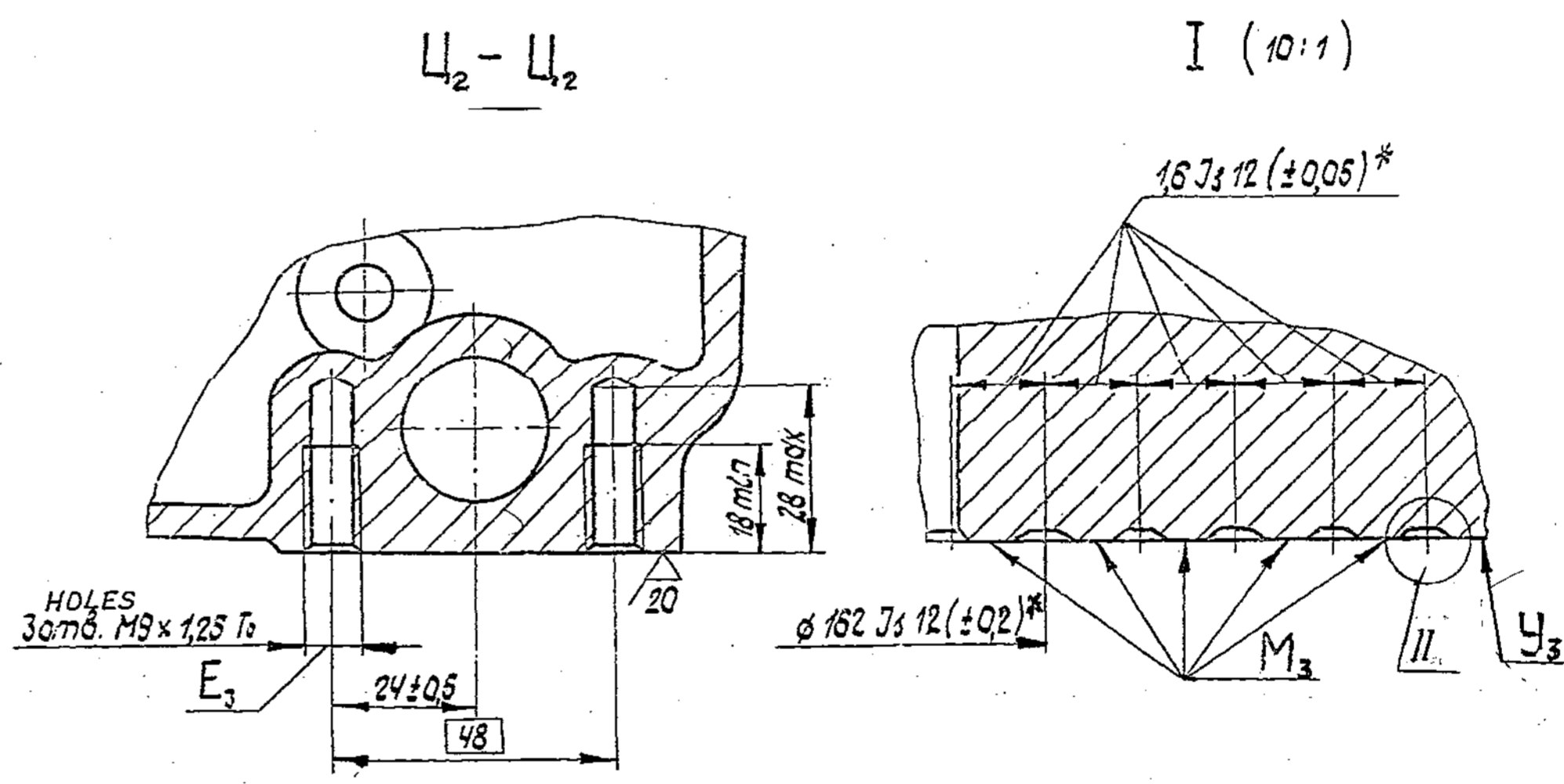
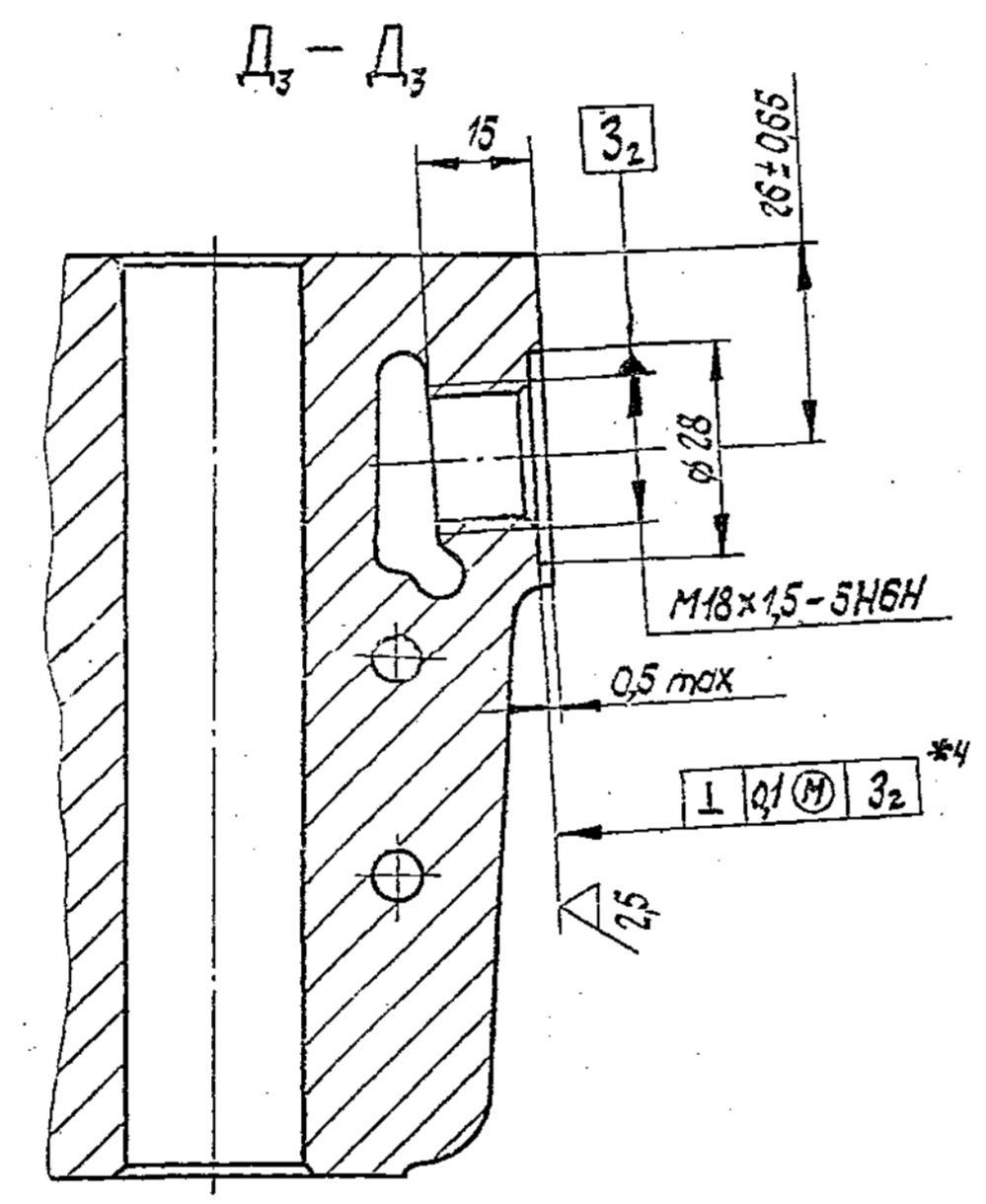
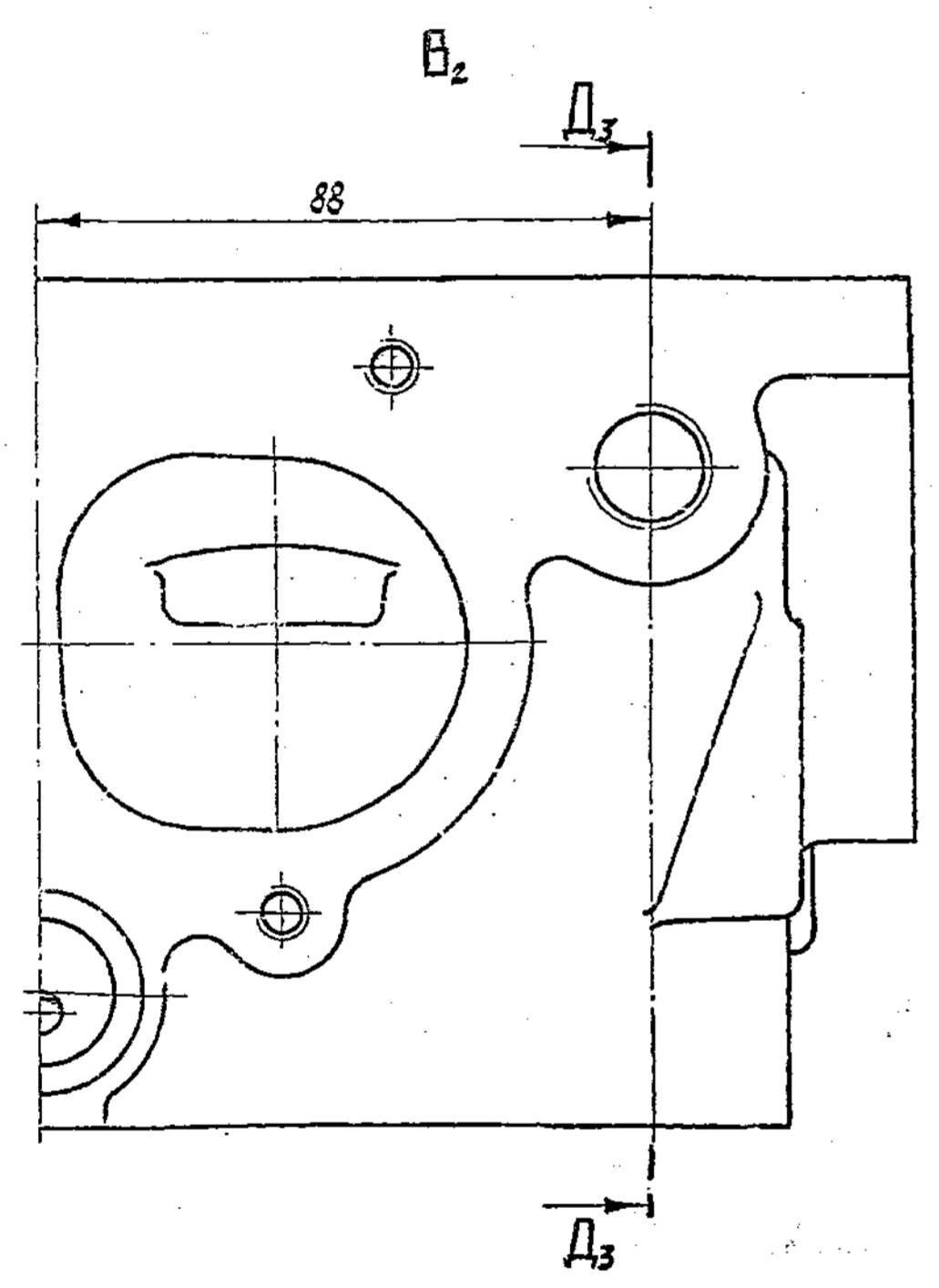

II (30:1)

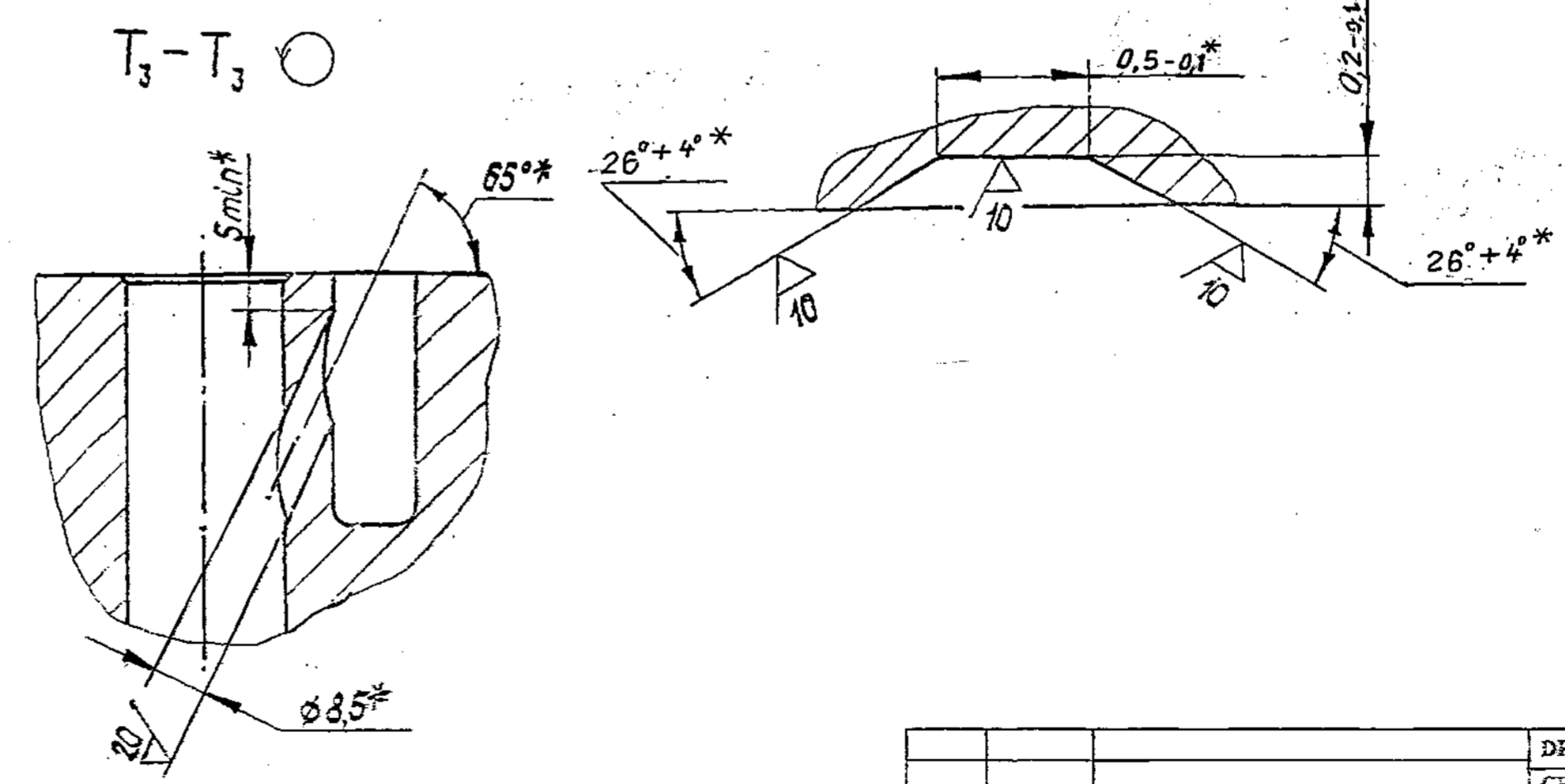
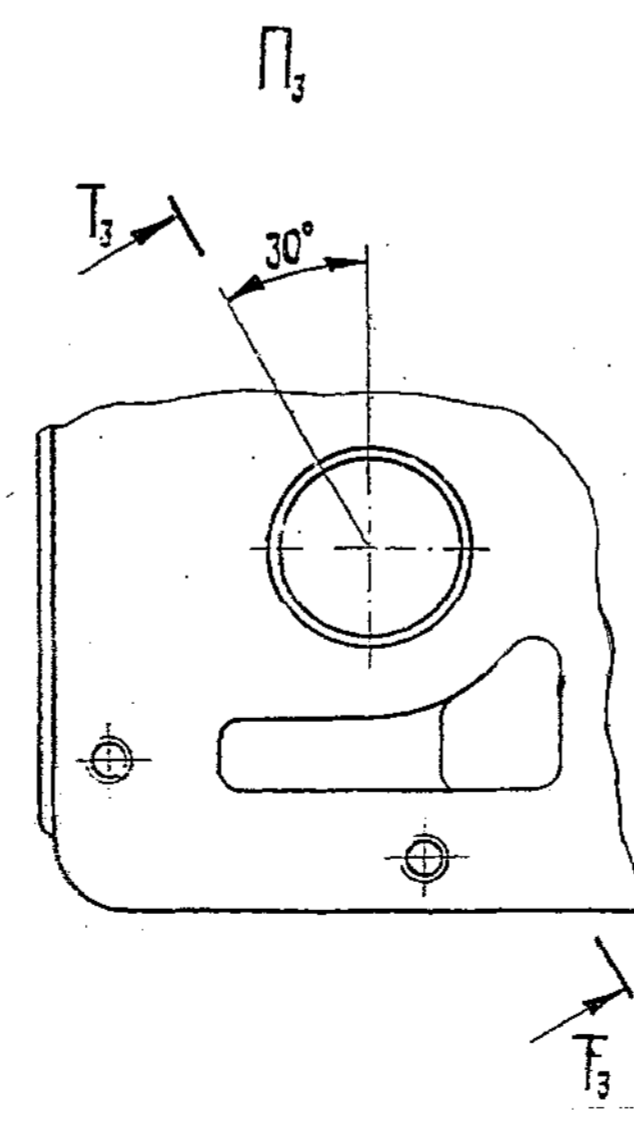
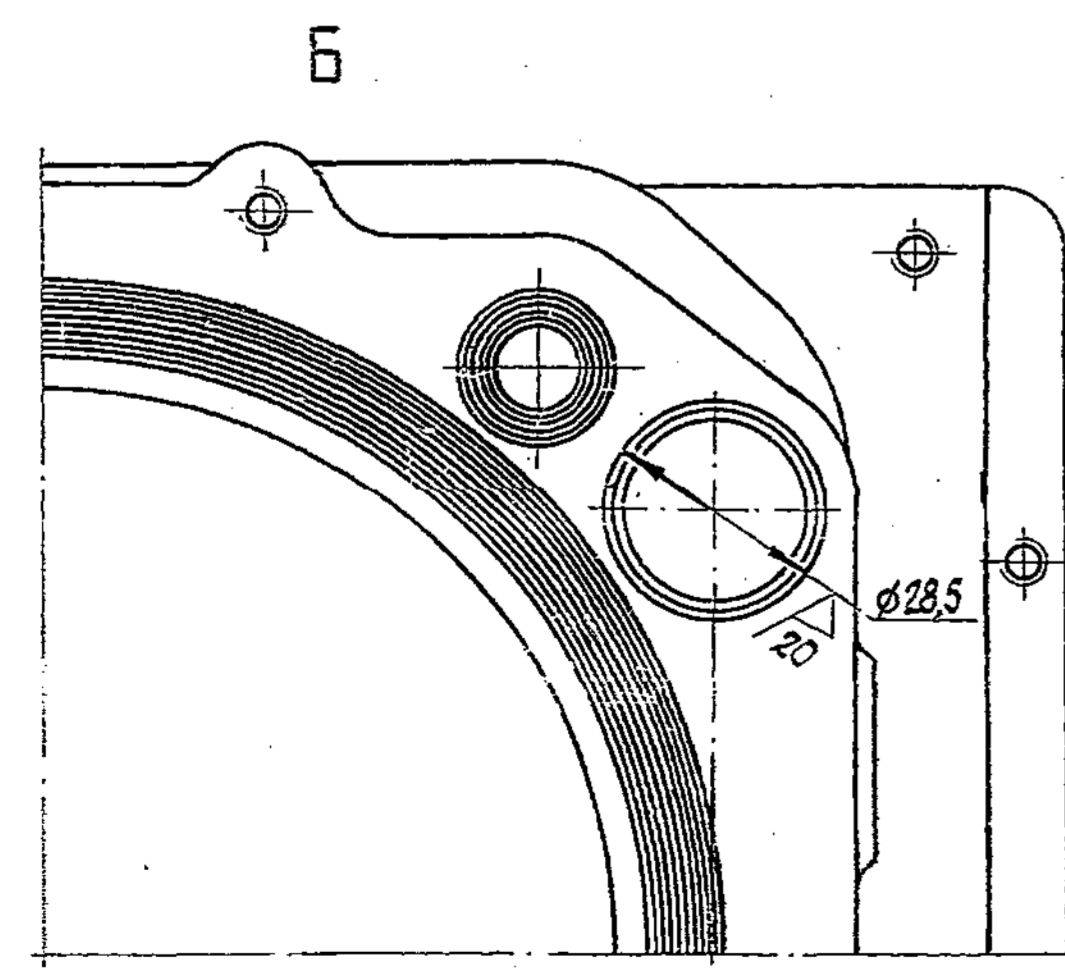

PILOT SAMPLE SHOULD BE APPROVED BY A H S P BEFORE BULK PRODUCTION.

EST. WT. (Kg) TO BE STAMPED OR MARKED WHERE INDICATED THUS # (LETTERS)

ALL SHARP EDGES AND CORNERS TO BE REMOVED UNLESS OTHERWISE STATED MACHINED CORNERS TO HAVE R OUT-SIDE R INSIDE EQUIVALENT CHAMFERS ARE PERMISSIBLE.

DRN	CHD	APED	DATE	MATERIAL:-	USED ON:- Cb.306-01-20
			16-05-2012	CONTROLLERATE OF QUALITY ASSURANCE (HEAVY VEHICLES) AVADI	
SCALE:- 1:1	DIMENSIONS IN mm		TOLERANCE ON DIMNS UNLESS OTHERWISE STATED IS: 2102-69		TITLE:- R.H CYLINDER HEAD
ISSUE	DATE	NATURE OF AMENDMENTS		D S CAT NUMBER	DRAWING NUMBER 306-16-19

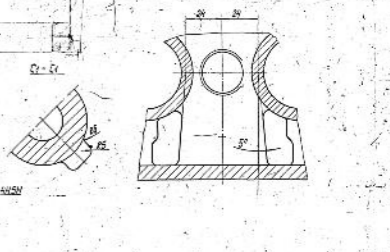
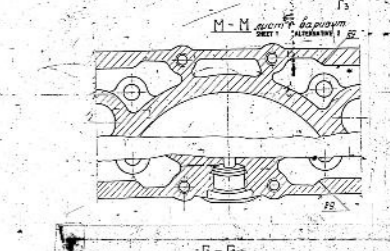
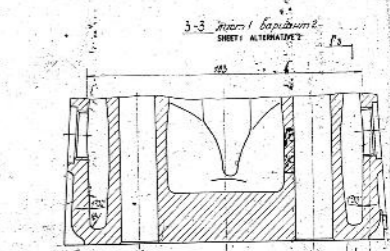
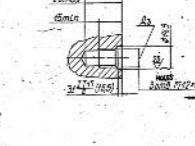
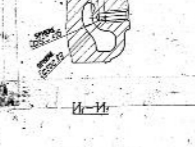
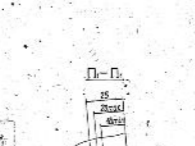
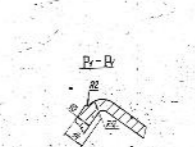
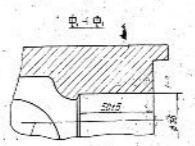
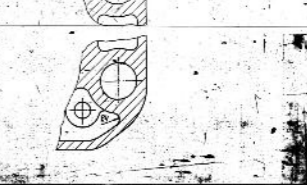
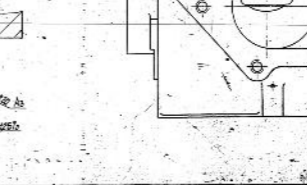
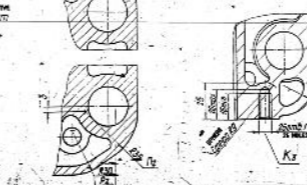
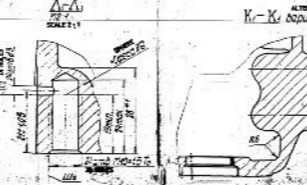
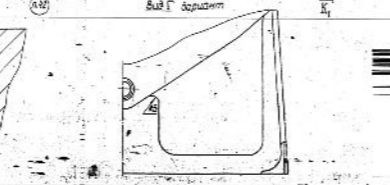
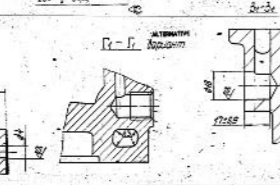
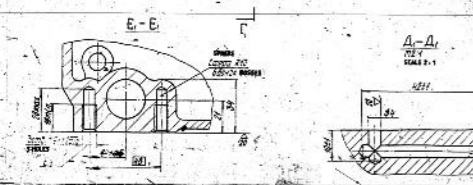
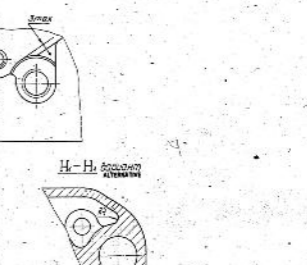
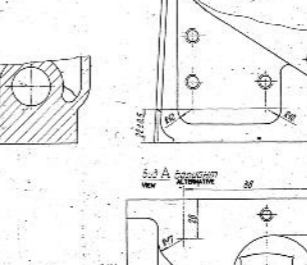
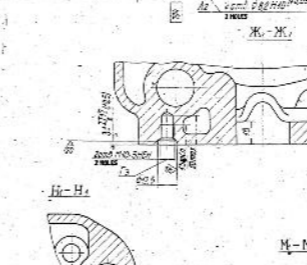
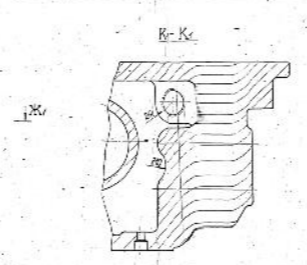
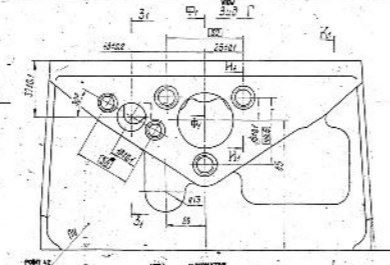
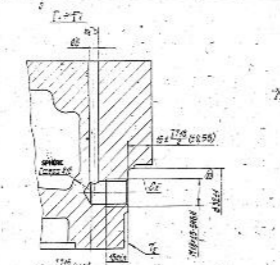
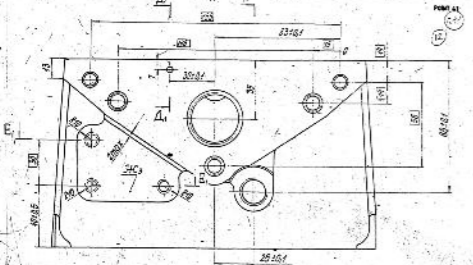
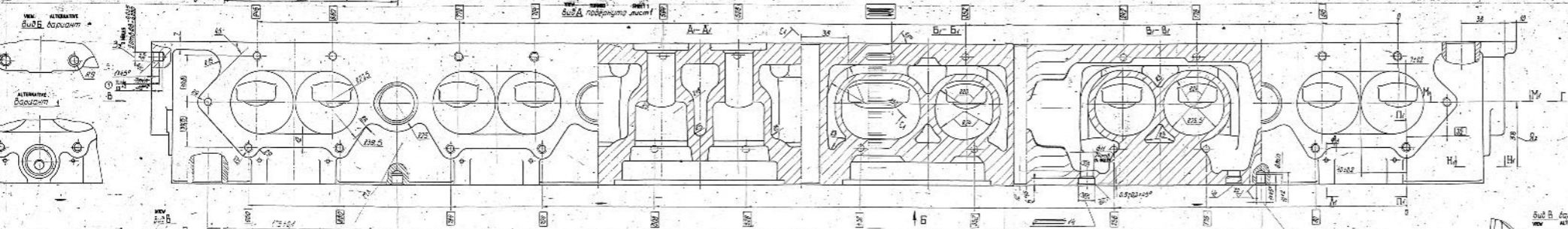
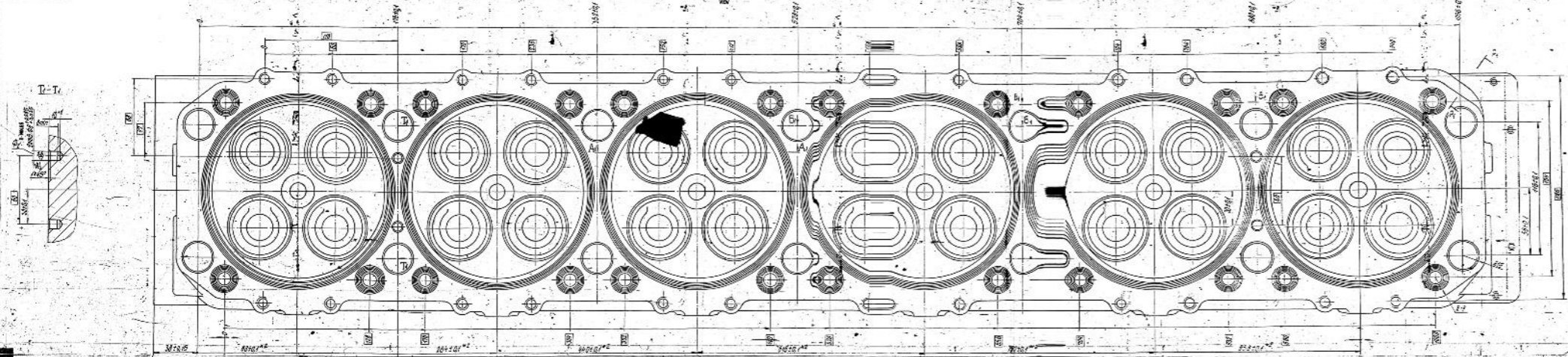

PART SAMPLE SHOULD BE APPROVED BY A 37 ENGINE MANUFACTURER	
DATE	BY
REVISION NO.	REVISION
DESIGNED BY	DESIGN
CHECKED BY	CHECK
APPROVED BY	APPROVE
DATE	BY
BLOCK HEAD R M	
92-91-902	