

2

THIS DOCUMENT AND THE INFORMATION CONTAINED IN IT ARE PROPRIETARY AND CONFIDENTIAL TO OFT. NO PERSON OR ENTITY IS ALLOWED TO COPY, REPRINT, REPRODUCE OR PUBLISH ANY PART OF THIS DOCUMENT, NOR DISCLOSE ITS CONTENTS TO OTHERS, NOR MAKE ANY USE OF IT, NOR ALLOW OR ASSIST OTHERS TO MAKE ANY USE OF IT UNLESS BY THE PRIOR WRITTEN EXPRESS AUTHORIZATION OF OFT AND THEN ONLY TO THE EXTENT AUTHORIZED. COPYRIGHT-OFT.

DWG NO 069201A-00

SH 1

1

SHEET REV RECORD

ALL SHEETS ARE THE SAME REVISION

REVISION RECORD

REV	ECO	DESCRIPTION	DATE	APVD
01		Freeze	27-Nov-12	
02		Restricted	25-Dec-13	
--	T00064	Identical To Previous Released	09-Apr-18	L. Goldshtein

NOTES:

1. INTERPRET THIS DRAWING IAW ASME Y14.100M.
2. MATERIAL: CRES BAR TYPE 17-4PH PER AMS 5643. (EQUIVALENT STEEL IS PERMITTED AFTER ELBIT APPROVAL).
3. HEAT TREATMENT TO H1150 PER MIL-H-6875 CLASS D.
4. DEBUR AND REMOVE SHARP EDGES APPROX. 0.3X45°.
5. PASSIVATION TREATMENT PER AMS-2700 METHOD 1 TYPE 8.
6. BAKE PART AFTER PLATING WITHIN 3 HOURS PER AMS-2759/9 TABLE 1 FOR 3 HOURS MINIMUM AT 191 °C.
7. QUALITY ASSURANCE PROVISIONS:
7.1 QUALITY ASSURANCE PROVISIONS FOR THIS ITEM PER RDMQD00012P.
8. PACKAGING AND PACKING:
THE FINISHED PART SHALL BE PRESERVED AND PACKAGED IN ACCORDANCE WITH COMMERCIAL PRACTICE.
9. IDENTIFY PER MIL-STD-130 PARA 4.1.B, BY LABELING ITS CONTAINER WITH THE PART NUMBER. CHARACTERS MINIMUM TEXT HEIGHT 1.25 MM.

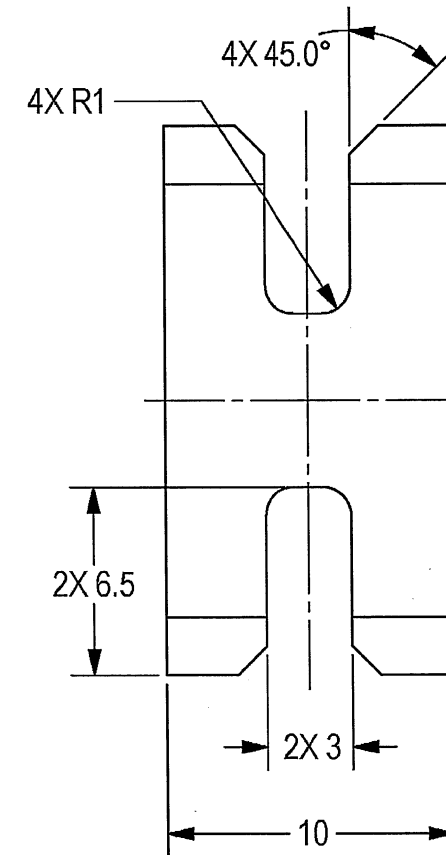
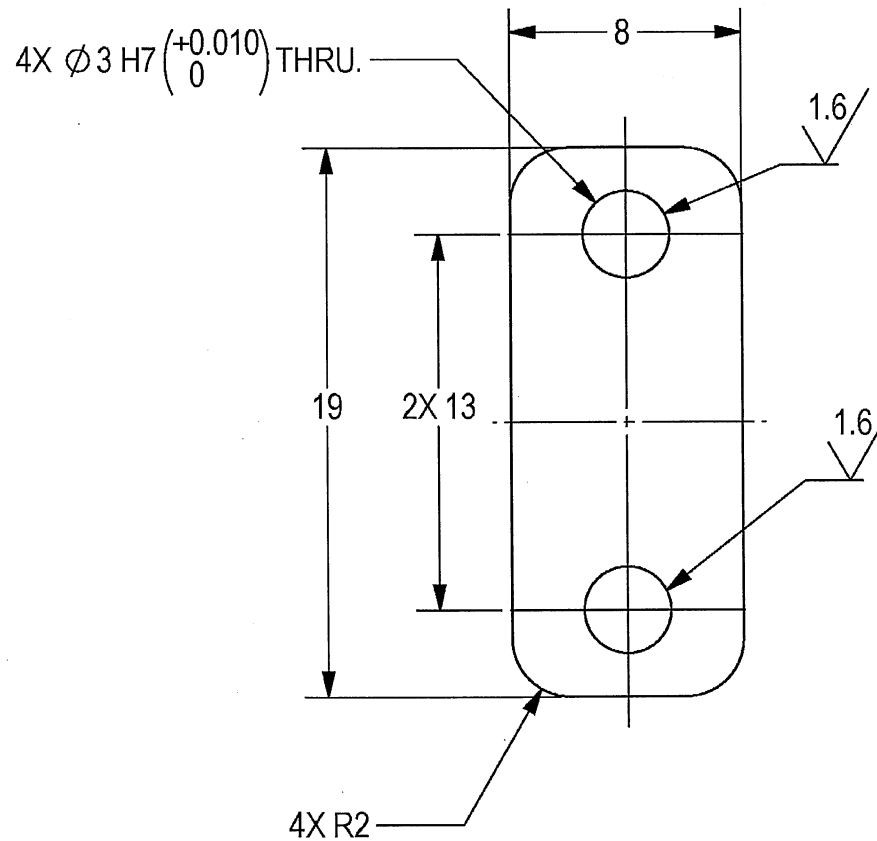

B

B

A

A

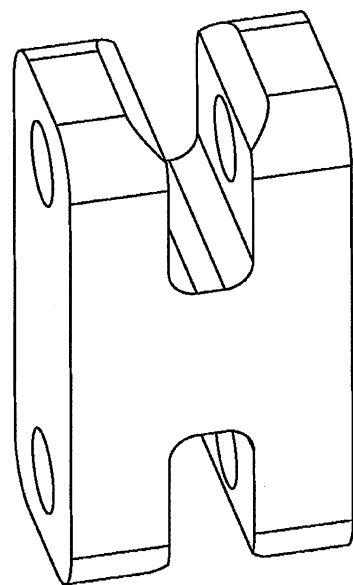

(WEIGHT APPROX.: 0.008 Kg.)

SEE ATTACHED MEDIA

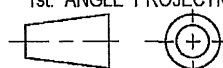
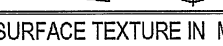
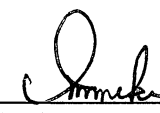
UNLESS OTHERWISE SPECIFIED		SIGNATURE	DATE	 ORDNANCE FACTORY TIRUCHIRAPPALLI	
DIMENSIONS ARE IN MM PER ASME Y14.5M - 1994		DRAWN	11/9/20		
TOLERANCES		CHECKED		TITLE	
LINEAR	ANGULAR	HOS/DDO	3/5/20	ADAPTOR, SPRING	
±0.2	±0.5°	OFFICER/PRODN		FOR: PEDESTAL ASSY	
1st ANGLE PROJECTION		OFFICER/QC		OF: 12.7MM SRCG	
		OFFICER/DDO		SIZE	CAGE CODE
SURFACE TEXTURE IN Micro M				B	2291A
				DWG NO	069201A-00
PROJECT OFFICER				SCALE	4:1
				AUTOMATED DRAWING (SW)	
PLM Control				SHEET 1 OF 1	

2

1