

ORDNANCE FACTORY
DEHRADUN

DRAWN BY: P.C.SINGH

TR-

CH- *PC*

APPROVED

JWM
JWM/D.O.

WM/P
WM/P

DRG. NO
CQA(1)789/9 SH-5

BINOCULAR 8x30 R
VALVE COMPLETE

DT.-12-06-2010 SCALE - NTS

MATL.

TREAT.

AS ABOVE

AS ABOVE

D.A.No.1/15 Dt.2/1/2015

SHEETS. 5

SHT. NO. 5

AMENDMENTS

OPD/DO/002

DRAWING No.-
MCT-2926/1

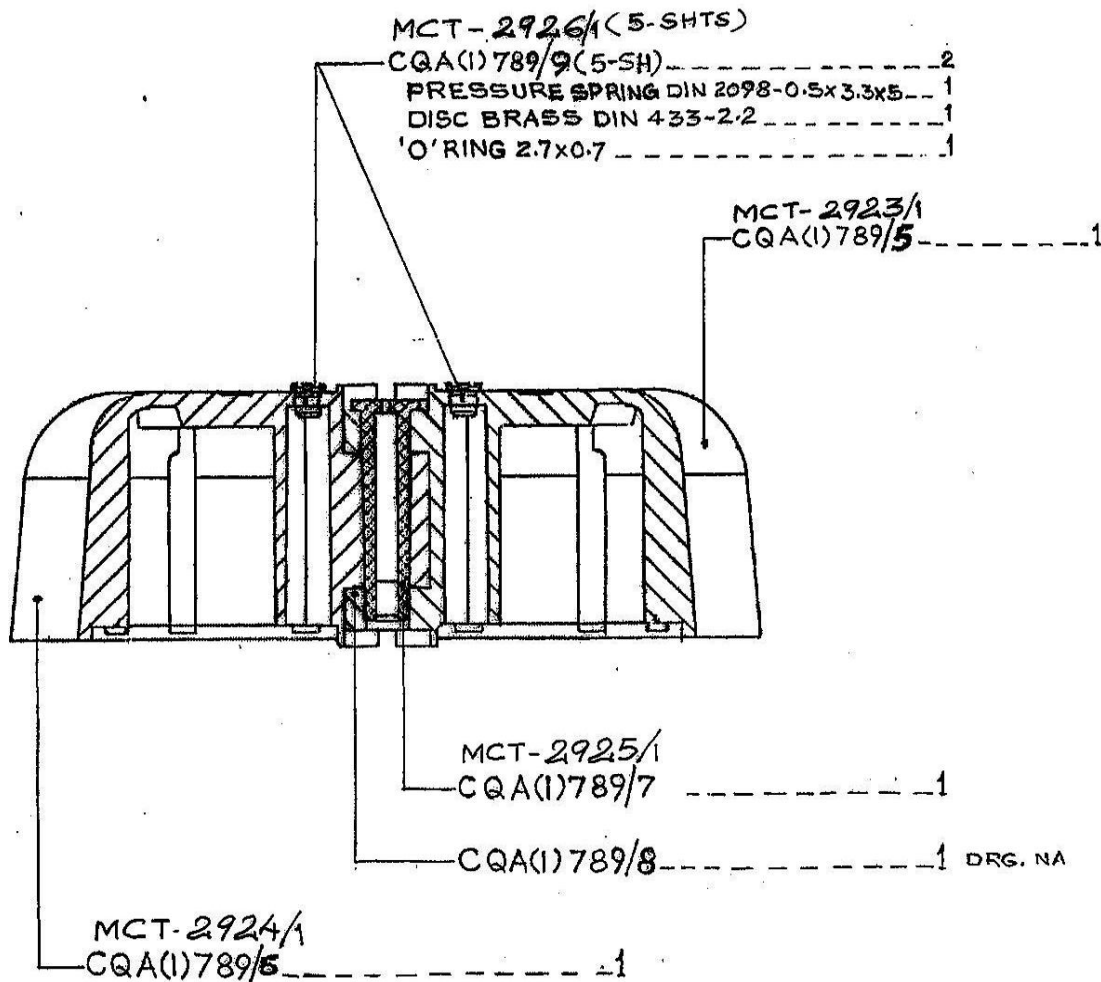

TEMPERATURE COMPATIBILITY OF THE COMPONENTS. (+80° ± 3° & 40 ± 3°)

ORDNANCE FACTORY DEHRADUN	DRAWN BY: P.C.SINGH
	TR-
	CH- <i>[Signature]</i>
	APPROVED <i>[Signature]</i> JWM/D.O. WM/P

BINOCULAR 8x30 R
HOUSING COMPLETE

DRG. NO
CQA(I) 789/SA-3

	DT.-12-06-2010	SCALE - NTS
	MATL.	TREAT.
	---	---
DA.No.01/2015 Dt.02/01/2015	SHEETS. 1	SHT. NO. 1
AMENDMENTS	DRAWING NO.	
OPD/DO/002	MCT-2922/1	

ORDNANCE FACTORY
DEHRADUN

JWM/DO	<i>[Signature]</i>
W/M/P	<i>[Signature]</i>
APPROVED	<i>[Signature]</i>
CH -	<i>[Signature]</i>
TR -	
DRAWN BY:	P.C.SINGH

DRG NO
COA(II) 789/6

BINOCCULAR 8x30 R HOLDER OPTICAL ELEMENT

MCT-2924/1		OFD/DO/002
DRAWING NO.		AMENDMENTS
SHT. NO. 1	SHEETS. 1	DA. No. 01/2015 Dt. 2/1/2015
AS ABOVE	AS ABOVE	
TREAT	MATL	
SCALE - NTS	DT-12-06-2010	

MAX. ALLOWABLE DRAFT ANGLE 30°
NOT DIMENSED EDGES CHAMFER 0.2
MISSING DIMENSIONS ACCORDING TO CAD-DATAS
NOT DIMENSIONED SIDE THICKNESS 2.8 mm.
TEMPERATURE COMPATIBILITY OF THE
COMPONENTS. (+60° F ± 3° & -40 ± 3°)

MATL:- PC-GFK 20%

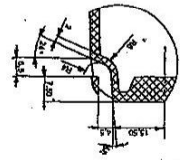

A-A VIEW ROTATED 90°

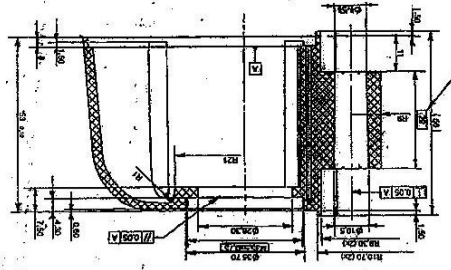
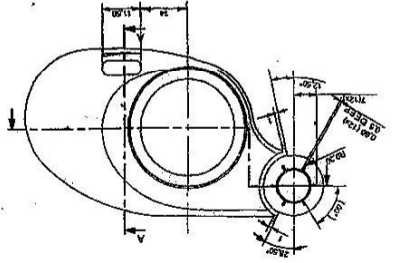

MATCHED WITH COUNTER PART

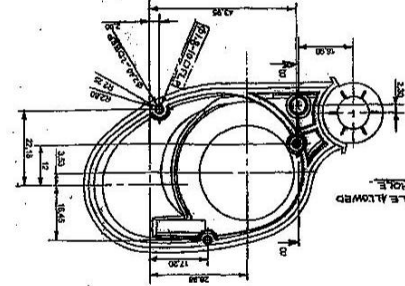
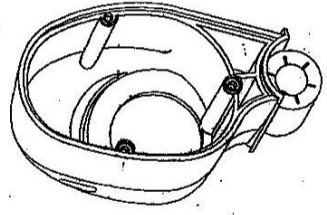
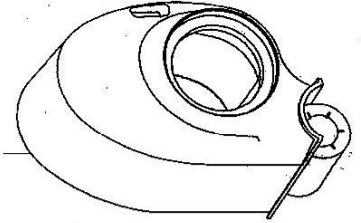

NO DRAFT ANGLE ALLOWED AT THIS BORE HOLE

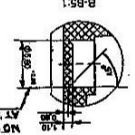

B-85-1

SCAN DRG.

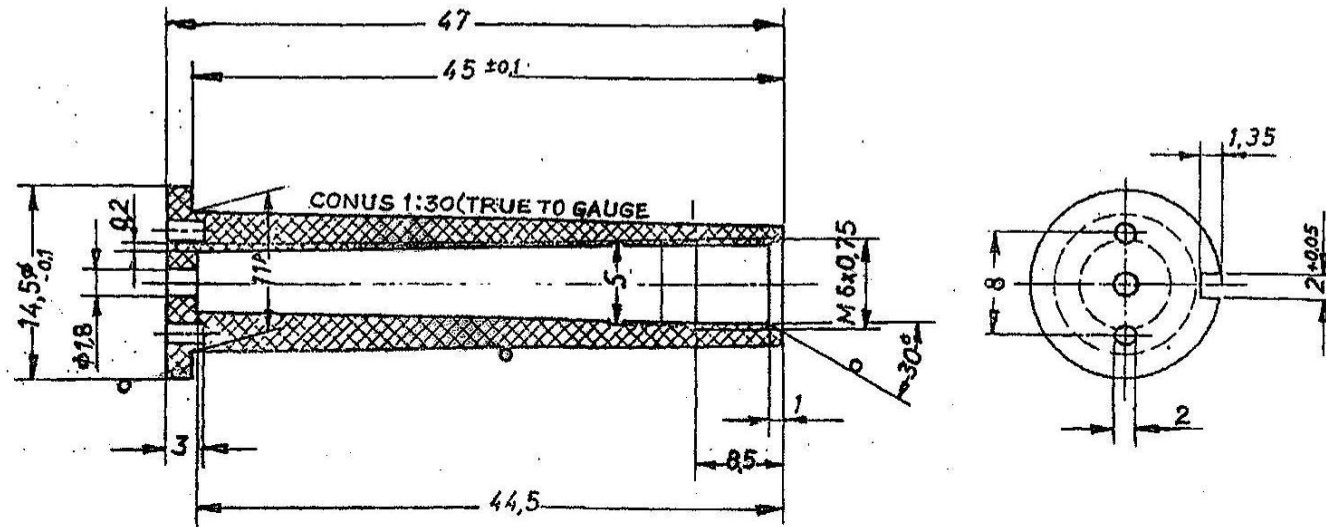

SURFACE 0 = ADMISSIBLE RUN-OUT 0.03

TEMPERATURE COMPATIBILITY-
OF THE COMPONENTS.

(+80° ± 3° & -40 ± 3°)

MATL:- MACROLON B020 RAL 19/004

ORDNANCE FACTORY
DEHRADUN

DRAWN BY: P.C.SINGH

TR-

CH- *PC*

APPROVED

JWM

JWM/D.O.

WM

WM/P

DRG. NO
CQAH 789/7

BINOCULAR 8x30 R
PLASTIC BAR

DT.-12-06-2010 SCALE - NTS

MATL. TREAT.

AS ABOVE AS ABOVE

DATE: 01/2015 DT: 2/1/2015

SHEETS. 1 SHT. NO. 1

AMENDMENTS

DRAWING NO.

OFD/DO/002

MCT- 2925

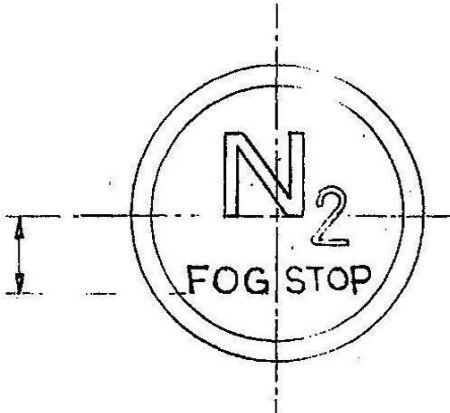
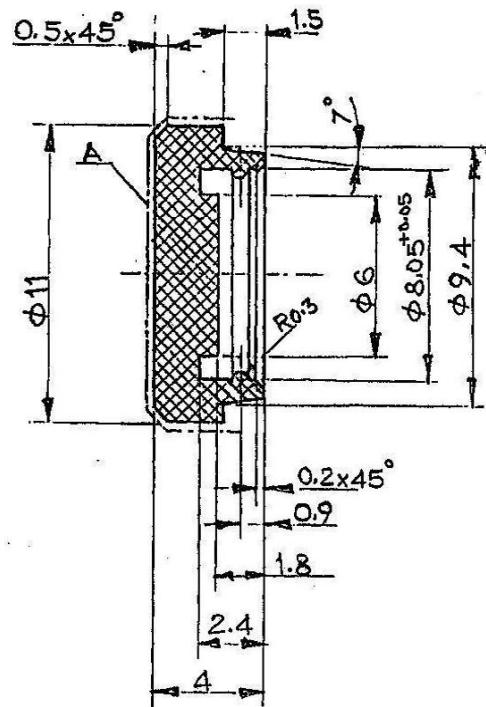

SURFACE 'A'=VISIBLE SURFACE
 N₂ = HELVETICA BOLD 12 PT.
 FOG STOP = HELVETICA COMPACT 8PT.
 FONTS 0.2-0.3 DEEPEMED
 BASE AREA HIGH GLOSS FINISHED.

TEMPERATURE COMPATIBILITY-
 OF THE COMPONENTS.
 (+80°±3° & -40 ±3°)

MATL:- PC
 FINSH & SPEC:- COLOUR: RAL 6014

ORDNANCE FACTORY DEHRADUN	DRAWN BY: P.C.SINGH
	TR-
	CH- <i>[Signature]</i>
	APPROVED <i>[Signature]</i> JWM/D.O. WM/P

BINOCULAR 8x30 R
 CABINET, DESICCATING

DRG. NO
CQA(II) 789/9 SH-(

	DT.-12-06-2010	SCALE - NTS
	MATL	TREAT.
	AS ABOVE	AS ABOVE
DA-01/15 dt 02/10/15	SHEETS. 5	SHT. NO. 1
AMENDMENTS OFD/DO/002	DRAWING No.- MCT-2926/1	

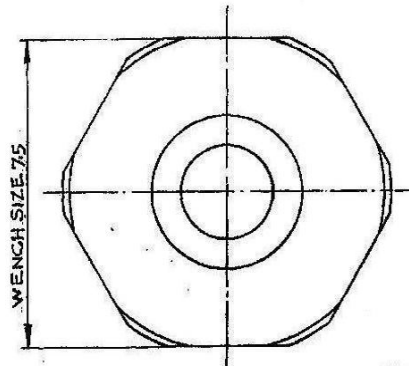
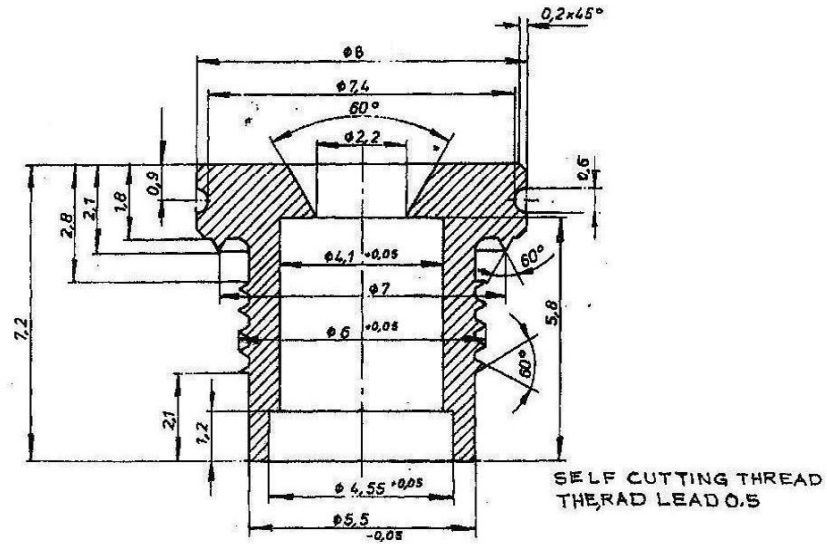

MATL:- Ms 58 OR Cu Zn 39 Pb3

ORDNANCE FACTORY
DEHRADUN

DRAWN BY: P.C.SINGH

TR-

CH-

APPROVED

JWM/D.O.

WM/P

DRG. NO. :-
CQA(II) 789/9 SH-2

BINOCULAR 8x30 R
VALVE HOUSING

DT.-12-06-2010 SCALE - NTS

MATL. TREAT.

AS ABOVE AS ABOVE

D.A. NO. 04/2015 DT. 2/1/2015 SHEETS. 5 SHT. NO. 2

AMENDMENTS

OFD/D0/002

DRAWING No.-
MCT-2926/1

BINOCULAR 8x30 R

TAPPET

DRG. NO

COMD(1) 789/9 SH-3

FIRST ANGLE PROJECTION

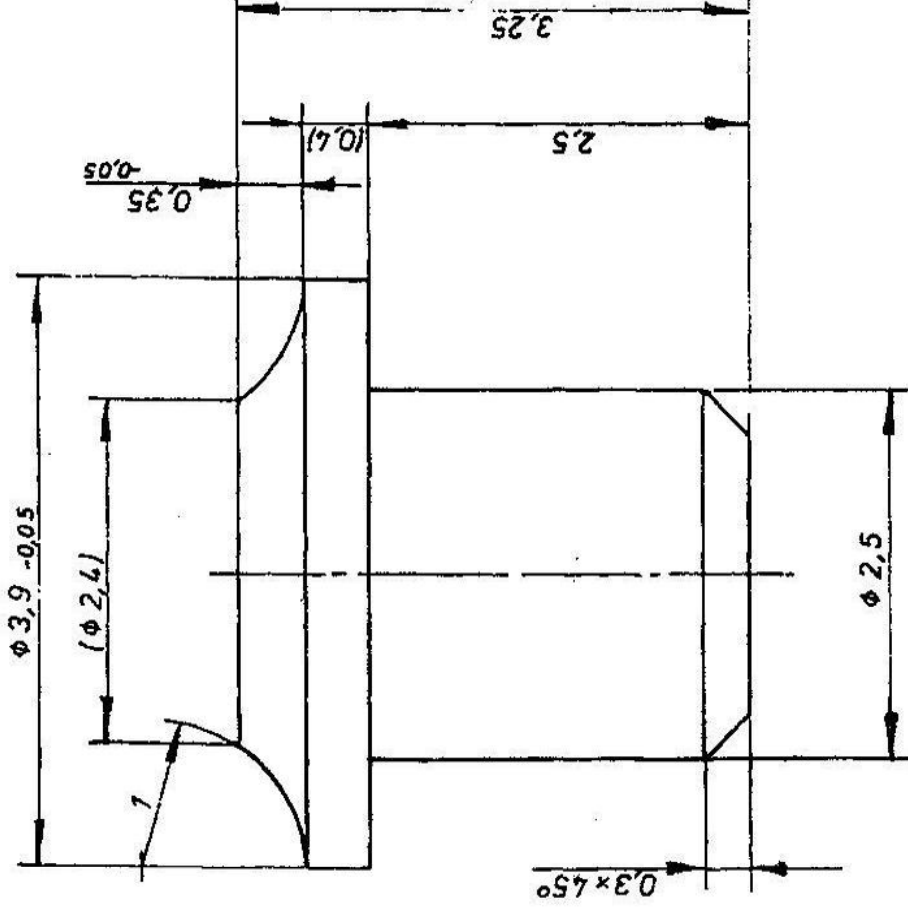

TEMPERATURE COMPATIBILITY
OF THE COMPONENTS. (+80±3° & -40±3°)

Φ
M 1:1



MATL:- BRASS 58 OR Cu Zn 39 Pb3

MADE BY: P.C.SINGH		DT. - 12-06-2010	SCALE - NTS
TR-		MATL.	TREAT.
CH- <i>dw</i>		AS ABOVE	AS ABOVE
APPROVED		SHEETS. 5	SHT. NO. 3
DA-01/15 dt-02/01/15 AMENDMENTS OFD/DO/002		DRAWING NO.	
<i>dw</i> JWM/D.O.		<i>P.Singh</i> WM/P	
MCT-292611			

ORDNANCE FACTORY, DEHRADUN

BINOULAR 8x30 R SELF CUTTING THREAD VALVE HOUSING

DRG. NO
COM(II) 789/9 SMM

FIRST ANGLE PROJECTION 

ORDNANCE FACTORY, DEHRADUN

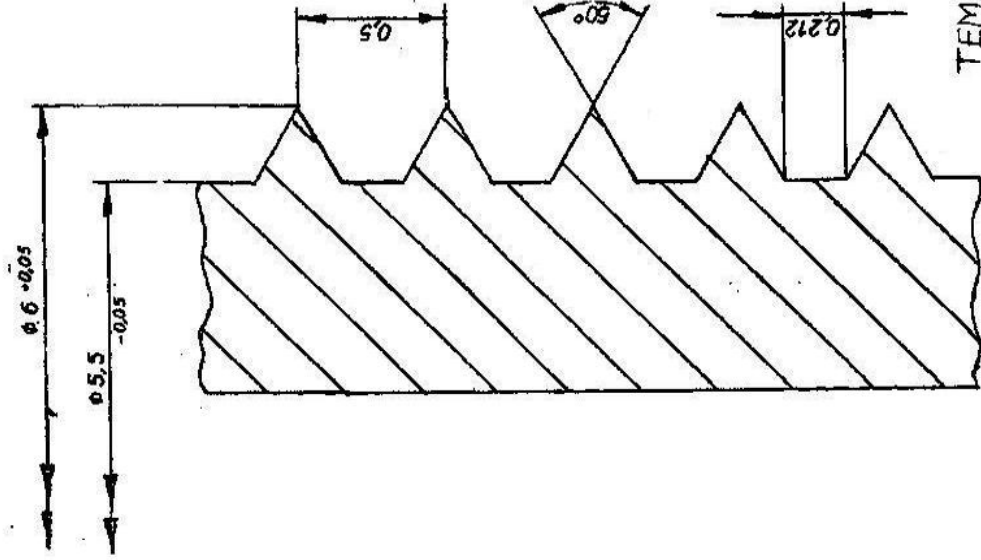

TEMPERATURE COMPATIBILITY
OF THE COMPONENTS.
(+80° ± 3° & -40 ± 3°)

DT. - 12-06-2010		SCALE - NTS
MADE BY: P. C. SINGH		MAIL
TR-		TREAT.
CH- <i>ch</i>		SHEETS. 5
APPROVED		SHT. NO. 4
DA-01/15 dt-02/01/15	<i>ch</i>	<u>DRAWING NO.</u>
AMENDMENTS	<i>ch</i>	<u>MCT-2926/1</u>
OFD/DO/002	JWM/D.O.	WM/P