

190000-5001 ON 100'SD

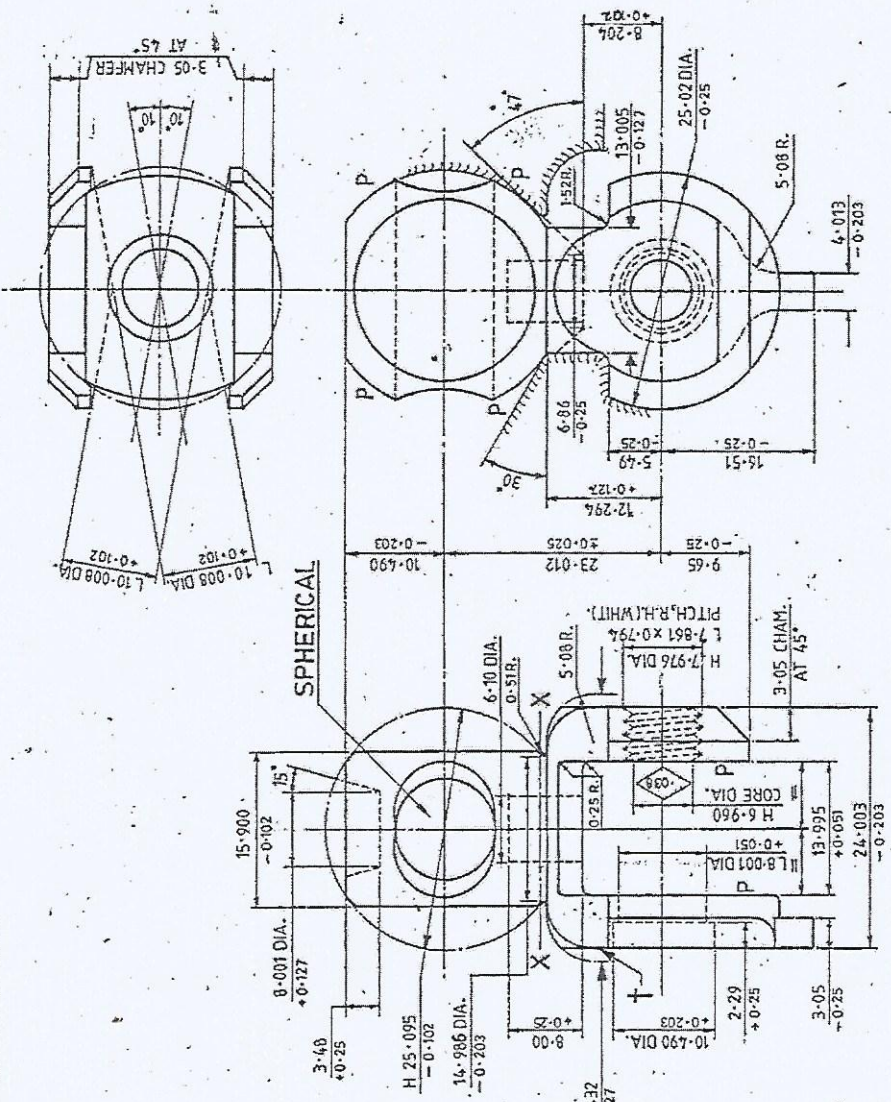

FOR EXPLANATION SEE D.D. NOTE SHEET E & 10.  
DIMNS. ARE IN mm.

TOLERANCE FOR UNTOLERANCED DIMENSIONS ± 0.13.  
ANGLES GIVEN IN DEGREES ± 5 MINUTES.  
ANGLES GIVEN IN DEGREES & MINUTES ± 2 MINUTES.

NOTE: SECTION ABOVE LINE 'X-X' HARDENED & TEMPERED TO 350-450 H.V.

MATERIAL: IS:5517-1993, DESIGNATION 55CB.  
INVESTMENT CASTING MATERIAL.

IS:10343-1999 GRADE 5N  
PROTECTIVE FINISH } PHOSPHATE TO SPECN. JSS. 0465-01:1994  
CLASS-1, OIL FINISH.  
POLISHED WHERE MARKED 'P'

† MANUFACTURER'S CODE TO BE MARKED HERE.

METRIC

28.09.16 (2695)-SA	MATERIAL AMENDED.	DRN.	CHD.	TRD. <i>Specimens</i>	COMP. <i>Norm</i>	AHSP: COA (SA), ICHAPUR
14-7-2003 25799-SA	PROFORMA CHANGED, ACTUAL SIZE VIEW DELETED, PROTECTIVE FINISH AMENDED, NEG. RE-TRACED AND DRG. RE-SEALED. PREVIOUS DC. NOS. 1560-SA, 1619-SA, 22234-SA, 22496-SA, 223518-SA.	SCALE: 2:1		EST. MASS: -		ASSY.
DATE AUTHY.	BRIEF RECORD					DGNR'S M.G. DET. NO. 1206 REF.
SEALED: D.C. NO. 15150-SA, DT. 18-5-77.	ZONE 1/C: D.O. G.O. SIGN.					PART NO.
NOMENCLATURE: BRACKET, BIPOD						DRG. NO.
						D.S. CAT. 1005-000061