

1. Заменитель материала сталь марок 08; 08кп; 10кп ГОСТ 1050-74. Допускается изготавливать из листа ГОСТ 19904-74.
2. Требования, предъявляемые к штамповке, по нормам 82050-16.
3. Покрытие Ц12±24.хр по ИЛ-483-82 с удалением водородной хрупкости или лак ГФ-95 по ИЛ-09-73.
4. В тропическом исполнении покрытие Кд 9.хр по ИЦЛ-104 с удалением водородной хрупкости или лак ГФ-95 по ИЛ-09-73.
- 5.* Размеры для справок.

- 1 ALTERNATE MATERIAL : STEEL, GRADES 08, 08Kp 10Kp GOST 1050-74. MAY BE MANUFACTURED FROM SHEET GOST 19904-74.
- 2 REQUIREMENTS FOR STAMPING IN ACCORDANCE WITH STANDARD 82050-16.
- 3 COATING : Zn 12 ... 24, CHROMATIZING AS PER ИЛ - 483-82 WITH ELIMINATION OF HYDROGEN EMBRITTLEMENT OR VARNISH ГФ - 95 AS PER ИЛ - 09-73.
4. IN TROPICALIZED CONSTRUCTION:
COATING : Cd 9, CHROMATIZING IN ACCORDANCE WITH ИЦЛ 104 WITH ELIMINATION OF HYDROGEN EMBRITTLEMENT OR GLYPHAL VARNISH ГФ 95 IN ACCORDANCE WITH ИЛ - 09-73.
- 5 *DIMENSIONS FOR REFERENCE

(A) EQUIVALENT MATERIAL
Gr.DD 15:513-1994

PILOT SAMPLE SHOULD BE APPROVED BY A H S P BEFORE BULK PRODUCTION.

EST. WT. 0.0115 Kg TO BE STAMPED OR MARKED WHERE INDICATED THIS = (LETTERS)
ALL SHARP EDGES AND CORNERS TO BE REMOVED UNLESS OTHERWISE STATED MACHINED CORNERS TO HAVE R OUTSIDE R INSIDE EQUIVALENT CHAMFERS ARE PERMISSIBLE.

3. 08кп 03.114. 11/6/88. 10.10.10
ИЗМ. ЛУСТ. В ОБЪЕМ. ПОДП. ДОК.

ERN	10.03.10	MATERIAL :- STRIP 08кп - М - 2 - 1x12 ГОСТ 503-81	USED ON :- СБ 322-14-4 СБ 322-15-4
APPD	29-3-88	CONTROLLERATE OF QUALITY ASSURANCE (HEAVY VEHICLES) A V A O I	
SCALE	1:2:1	TITLE CLIP OF 6 PIPES	
EMENSIONS IN mm.		D S CAT NUMBER	
TOLERANCE ON DIMNS UNLESS OTHERWISE STATED IS 2102-69		DRAWING NUMBER 322-69	
ISSUE	DATE	NATURE OF AMENDMENTS	

ORG. REDRAWN BASED ON NEW ISSUE
ORG INDIAISED BASED ON RUSSIAN ORIGINAL ISSUE No: 0 (DK 03)

A-7

SIZE A2



rolled stock of group B class 4 GOST 1051-73 may be used. To ensure high quality of coating, it is allowed to eliminate surface defects of rolled stock with decrease of dimension as per accuracy class - 5.

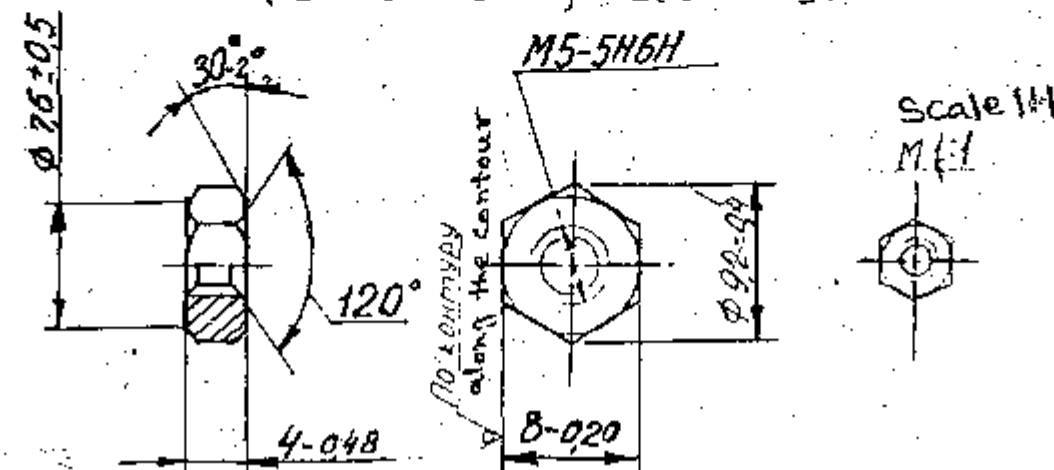

- The component may be manufactured from Steel GOST 1050-74.
- Chamfer 120° should be made up to the major diameter of thread.
- Shift of hole axis up to 0.25 mm. is permitted.
- The thread may be checked before coating.
- Coating :- Cd 9, Chromating as per UZS-104 with elimination of Hydrogen embrittlement.
- The rest of the technical requirements as per standard 82052-00.
- Alternate material :- Steel, grades 40 and 50 GOST 1050-74.

EXPLANATORY NOTE

9. a) REFERENCE MATERIAL QUOTED:
 GAUGED HEXAGONAL STEEL BAR CLASS OF ACCURACY 4, 0.01-0.100mm A/F TO GOST 8560-78 FROM HIGH GRADE SIZED STEEL SURFACE QUALITY '6' TO GOST 1051-73 AND MANUFACTURED IN ACCORDANCE WITH QUALITY CARBON STRUCTURAL STEEL GRADE 45 TO GOST 1050-74
- b) REFERENCE NOTE ON ALTERNATE MATERIAL : QUALITY CARBON STRUCTURAL STEEL GRADES 40 AND 50 TO GOST 1050-74
- a) CHEMICAL COMPOSITION : AS PER GOST 1050-74

GRADE OF STEEL	CONTENT OF ELEMENTS %						REMARKS
	C	Si	Mn	Cr	S	P	
45	0.42-0.50	0.17-0.37	0.50-0.80	0.25	0.040	0.035	REF MATL
40	0.37-0.45	0.17-0.37	0.50-0.80	0.25	0.040	0.035	ALT MATL
50	0.47-0.55	0.17-0.37	0.50-0.80	0.25	0.040	0.035	ALT MATL

RESIDUAL CONTENT OF COPPER AND NICKEL SHOULD NOT EXCEED 0.25% EACH

b) MECHANICAL PROPERTIES : AS PER GOST 1050-74

GRADE OF STEEL	ULTIMATE TENSILE STRENGTH Kgf/mm ²	YIELD POINT Kgf/mm ²	ELONGATION %	REDUCTION IN AREA %	IMPACT STRENGTH Kgf/cm ²	HARDNESS B H N MAX	REMARKS
45	61	36	16	40	5	229	REF MATL
40	58	34	19	45	6	217	ALT MATL
50	64	38	14	40	4	241	ALT MATL

Material: STEEL 709M40 (EN-19) TO BS-970 Pt-1-1983

PILOT SAMPLE SHOULD BE APPROVED BY A H S P BEFORE BULK PRODUCTION.

EST. MASS. 0.0812 Kg TO BE STAMPED OR MARKED WHERE INDICATED THIS * LETTERS)

ALL SHARP EDGES AND CORNERS TO BE REMOVED UNLESS OTHERWISE STATED MACHINED CORNERS TO HAVE R OUTSIDE R INSIDE EQUIVALENT CHAMFERS ARE PERMISSIBLE.

DRN	DRN	MATERIAL: HEXAGON BAR	USED ON:
CHD	DRN	84 GOST 8560-78	CE-20-35-00-5
TCD	DRN	45 B GOST 1051-73	CB 3335 00 24
APPD	DRN		
DATE	05-02-2009	CONTROLLERATE OF INSPECTION (HEAVY VEHICLES) AVADI	
SCALE	2:1	TITLE:--	
DIMENSIONS IN mm.		NUT M5	
TOLERANCE ON DIMNS UNLESS OTHERWISE STATED.		D S CAT NUMBER	
A	18.5.09	DRAWING NUMBER	
ISSUE	DATE	351 13	





KVD.No. 78696

DRAWING NUMBER
353-93-1

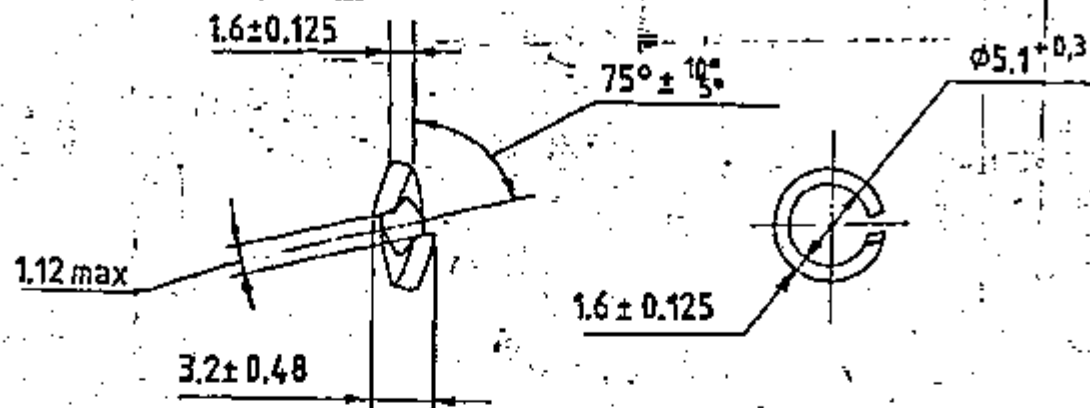

1. IN TROPICAL MANUFACTURE, COATING Cd 9 Cr AS PER U/L-104 WITH REMOVAL OF HYDROGEN EMBRITTLEMENT.
2. WASHER ST65Γ09.GOST 6402-70 MAY BE USED, IN VISUAL AND TROPICAL MANUFACTURE.

PILOT SAMPLE SHOULD BE APPROVED BY A H S P BEFORE BULK PRODUCTION.

EXPLANATORY NOTE:

MATERIAL QUOTED: WASHER ST. 65Γ. 06 GOST 6402-70.

CORRESPONDS DESIGN AND DIMENSIONS OF SPRING (LOCK) WASHERS.

06 : CONVENTIONAL SYMBOL OF FINISH. (PARKERISING FOLLOWED

5 : NOMINAL THREAD DIA OF BOLT OR SCREW BY OILING).

T = HEAVY ; 65Γ = GRADE OF STEEL AS PER GOST 1050-74.
(65G)

CHEMICAL COMPOSITION: AS PER GOST 1050-74.

CONTENT OF ELEMENTS %							
C	Si	Mn	Cr	S	P	Cu	Ni
MAXIMUM							
0.62-0.70	0.17-0.37	0.90-1.20	0.25	0.040	0.035	0.25	0.25

WEIGHT OF STEEL WASHERS AND THEIR RESILIENCE PROPERTIES AS PER GOST 6402-70.

THEORITICAL WEIGHT OF 1000 STEEL WASHERS IN kg = 0.424.

ESTIMATED RESILIENCE OF WASHERS FROM STEEL GRADE 65G = 28.7.
IN kg

MECHANICAL PROPERTIES: AS PER GRADE 65G GOST 1050-74.

YIELD POINT kgf/mm² (MIN) = 44

ULTIMATE TENSILE STRENGTH (MIN) = 75
kgf/mm².

ELONGATION % (MIN) = 9

REFERENCE NOTE: 09 = ZINC PLATING (CONVENTIONAL SYMBOLOF FINISH)

Ⓐ EQUIVALENT MATERIAL
75 C6 TO IS: 2507/EN 42 J BS: 970

		EST. WT. 1000 Pcs 0.424 Kg	TO BE STAMPED OR MARKED WHERE INDICATED THUS \oplus (LETTERS)	
		ALL SHARP EDGES AND CORNERS TO BE REMOVED UNLESS OTHERWISE STATED MACHINED CORNERS TO HAVE R OUT-SIDE R INSIDE EQUIVALENT CHAMFERS ARE PERMISSIBLE.		
A	16.8.10	1 st Alt. Comm. Meeting Minutes Point No.12 Dt: 26-10-09	MATERIAL:- ST 65 Γ 06 GOST 6402-70	USED ON CB 200-18-4 Cb 200-18-4
ISSUE	DATE	NATURE OF AMENDMENTS	CONTROLLERATE OF QUALITY ASSURANCE (HEAVY VEHICLES) AVADL	
DRN	16.8.10	SCALE:- 2 : 1 DIMENSIONS IN mm	TITLE WASHER	
CHOC	16.8.10	TOLERANCE ON DIMENSIONS UNLESS OTHERWISE STATED IS 2102 -69	D S CAT NUMBER	
TCD	16.8.10	ALL THREADS CONFORM TO	DRAWING NUMBER 353-93-1	
APPO	16.8.10			
DATE	16.8.10			
SIZE	A4			





DRAWING NUMBER
3335-38-3 TO
3335-38-6

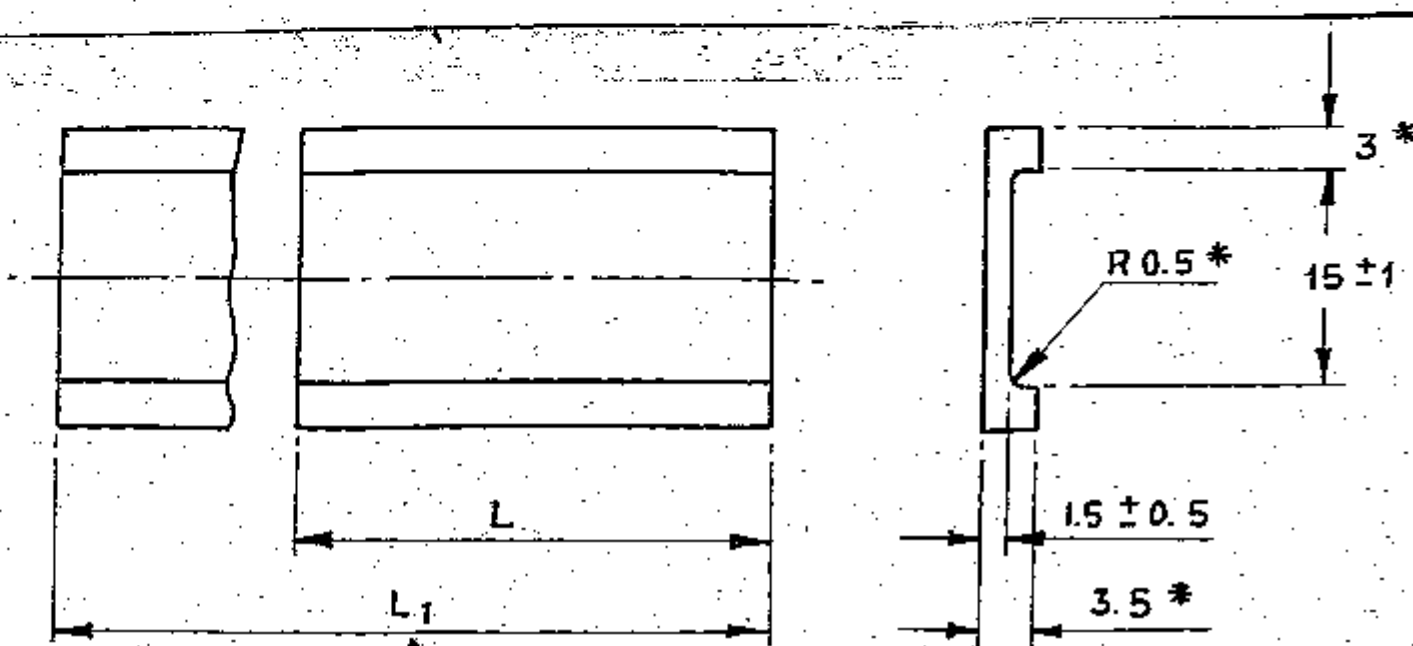

PART No.	L MM	MASS Kg.	USED ON	KVD No.
3335-38-3	26 ± 1	0.002		
3335-38-4	31 ± 2	0.0024	CS 3335-00-2430	78315
3335-38-5	42 ± 2	0.0032	CS 3335-00-2430	78435
3335-38-6	55 ± 0.2	0.0042		

- DIMENSIONS ARE TO BE ENSURED WITH TOOL.
- LENGTH OF DELIVERED BAND L_1 SHOULD NOT BE LESS THAN 1000 mm.
- MARK "3335-38-3" SHOULD BE PUT ON TAG OF COMPONENT TO BE DELIVERED.
- TO BE MADE AS PER TT III H 100 GOST 15152-69.
- THE REST OF THE REQUIREMENTS AS PER TY 005 216-75.

EXPLANATORY NOTE :-

6. REFERENCE MATERIAL QUOTED :
UNVULCANISED OIL AND PETROL RESISTANT
RUBBER CODE OF CLASSIFIER 25-1231,
RUBBER GRADE HO-68-1 TO TY 005-216-75.

3. MECHANICAL PARAMETERS :

- RUPTURE STRENGTH Kgf/cm^2 90 Min
 - ELONGATION OF RUPTURE % 250 Min
 - RESIDUAL ELONGATION AFTER RUPTURE % 12 Max.
 - HARDNESS No PP TO TH P DEVICE ARBITRARY 55-70
7. LIKELY EQUIVALENT GRADE / SPECIFICATION FOR
NITRILE CHLOROPRENE BASE TO BA 60 BS 2751-82
AND C 60 BS 2752-82.

* 02.0-27.000

3335-38-3

EXPLANATORY ADDED ON 4-6-92

(A) ALT. MATL.: RUBBER GRADE BNC TO SPECN. CQA(HV)/NBR+CR

PILOT SAMPLE SHOULD BE APPROVED BY A H S P BEFORE BULK PRODUCTION.

EST. WT.	TO BE STAMPED OR MARKED WHERE INDICATED THUS (LETTERS)
ALL SHARP EDGES AND CORNERS TO BE REMOVED. UNLESS OTHERWISE STATED MACHINED CORNERS TO HAVE R OUT - SIDE R INSIDE. EQUIVALENT CHAMFERS ARE PERMISSIBLE.	

DRN	—	MATERIAL	RUBBER HO-68-1	USED ON	—
CHD	<i>P. J. G.</i>		TY 005 216-75		
TCO	<i>[Signature]</i>	CONTROLLERATE OF QUALITY ASSURANCE (HEAVY VEHICLES)			
APPD	<i>[Signature]</i>	A V A D I			
DATE	8-7-86	TITLE : GASKET			
SCALE	2:1	D.S. CAT NUMBER			
DIMENSIONS IN mm		DRAWING NUMBER			
TOLERANCE ON DIMNS UNLESS OTHERWISE STATED IS 2102-69		3335-38-3 TO			
ALL THREADS TO CONFORM TO		3335-38-6			
A	27.05.08	Lt. No. TC/GEN/IND-III Dt. 02.04.08			
ISSUE	DATE	NATURE OF AMENDMENTS			

A-9
A2



DRAWING NUMBER
Cb.322-15-9

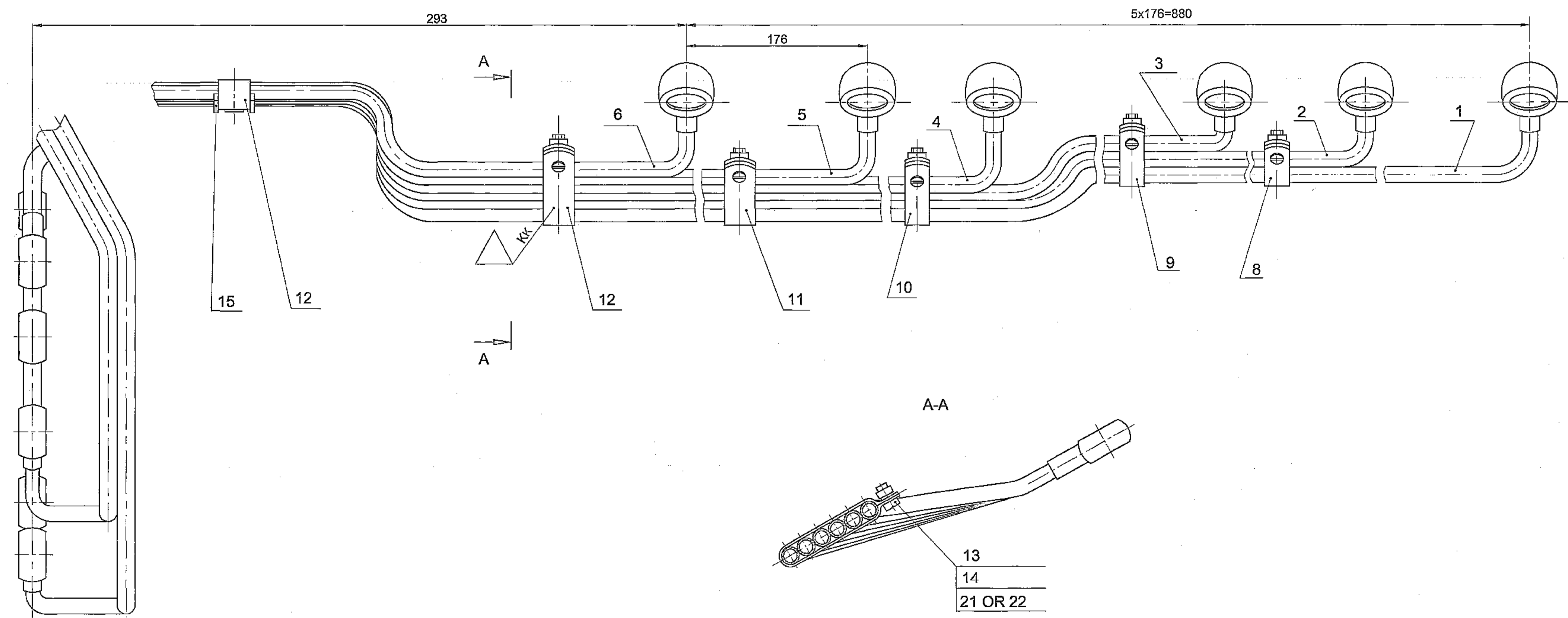

1. Carry out adjustment and final inspection for assembly units from Cb.322-07-9 to Cb.322-12-9 together on the dummy.
2. Make a complete set of assembly units Cb.322-15-9 and Cb.322-14-9 in pairs.
3. Stamp the manufacturing - factory No. and part number of assembly units Cb.322-14-9 and Cb.322-15-9 on tag for making a set while sending as spare parts.
4. Components and assembly units, having conventional symbol "TI" in the part list of given drawing in "remarks" column should have tropicalized construction as specified in the drawings for components.

DRAWING INDIANISED BASED ON RUSSIAN ORIGINAL ISSUE - 4

PILOT SAMPLE SHOULD BE APPROVED BY A H S P BEFORE BULK PRODUCTION.

EST. WT.(Kg) 1.460	TO BE STAMPED OR MARKED WHERE INDICATED THIS # (LETTERS)
ALL SHARP EDGES AND CORNERS TO BE REMOVED UNLESS OTHERWISE STATED MACHINED CORNERS TO HAVE R OUT-SIDE R INSIDE EQUIVALENT CHAMFERS ARE PERMISSIBLE.	

DRN	CHD	APPD	DATE	SCALE	DIMENSIONS IN mm	TOLERANCE ON DIMS UNLESS OTHERWISE STATED IS : 2102 - 69	ALL THREADS TO CONFORM TO
				1:1			
				MATERIAL :-		USED ON :-	
						Cb.322-00-9	
				CONTROLLERATE OF QUALITY ASSURANCE (HEAVY VEHICLES) AVADI			
				TITLE :-		DRAWING NUMBER	
				COMPRESSED AIR STARTING TUBING RH ASSY		Cb.322-15-9	
				D.S. CAT NUMBER			
				ISSUE		DATE	
				4A		13.08.08	
				D.O. CORRECTION		NATURE OF AMENDMENTS	

F-4
174
253
SIZE A1



USED ON

Cb 322-00-9

I/L CREATED BASED ON RUSSIAN ORIGINAL ISSUE - 3

ZONE	ITEM NO	DRAWING NUMBER	D S CAT NUMBER	DESCRIPTION	QTY	REMARKS
		Cb.322-15-9		COMPRESSED - AIR		
		ITEM LIST		STARTING TUBING		
				R . H ASSY.		
	1	Cb.322-07-9 & I/L		1 ST RH CYLINDER	1	
				TUBE ASSY.		
	2	Cb.322-08-9 & I/L		2 ND RH CYLINDER	1	
				TUBE ASSY.		
	3	Cb.322-09-9 & I/L		3 RD RH CYLINDER	1	
				TUBE ASSY.		
	4	Cb.322-10-9 & I/L		4 TH RH CYLINDER	1	
				TUBE ASSY.		
	5	Cb.322-11-9 & I/L		5 TH RH CYLINDER	1	
				TUBE ASSY.		
	6	Cb.322-12-9 & I/L		6 TH RH CYLINDER	1	
				TUBE ASSY.		
	8	322-65		CLIP FOR 2 TUBES	1	Tropical make

ISSUE	DATE	NATURE OF AMENDMENTS	ISSUE	DATE	NATURE OF AMENDMENTS
DRN			CONTROLLERATE OF QUALITY ASSURANCE (HEAVY VEHICLES) AVADI.		
CHD			TITLE : COMPRESSED - AIR STARTING TUBING R H ASSY.		
APPD					
DATE	30.6.07	SHT. NO. 1 OF 2	D S CAT NUMBER	ITEM LIST FOR Cb.322-15-9	

F-4
172/253





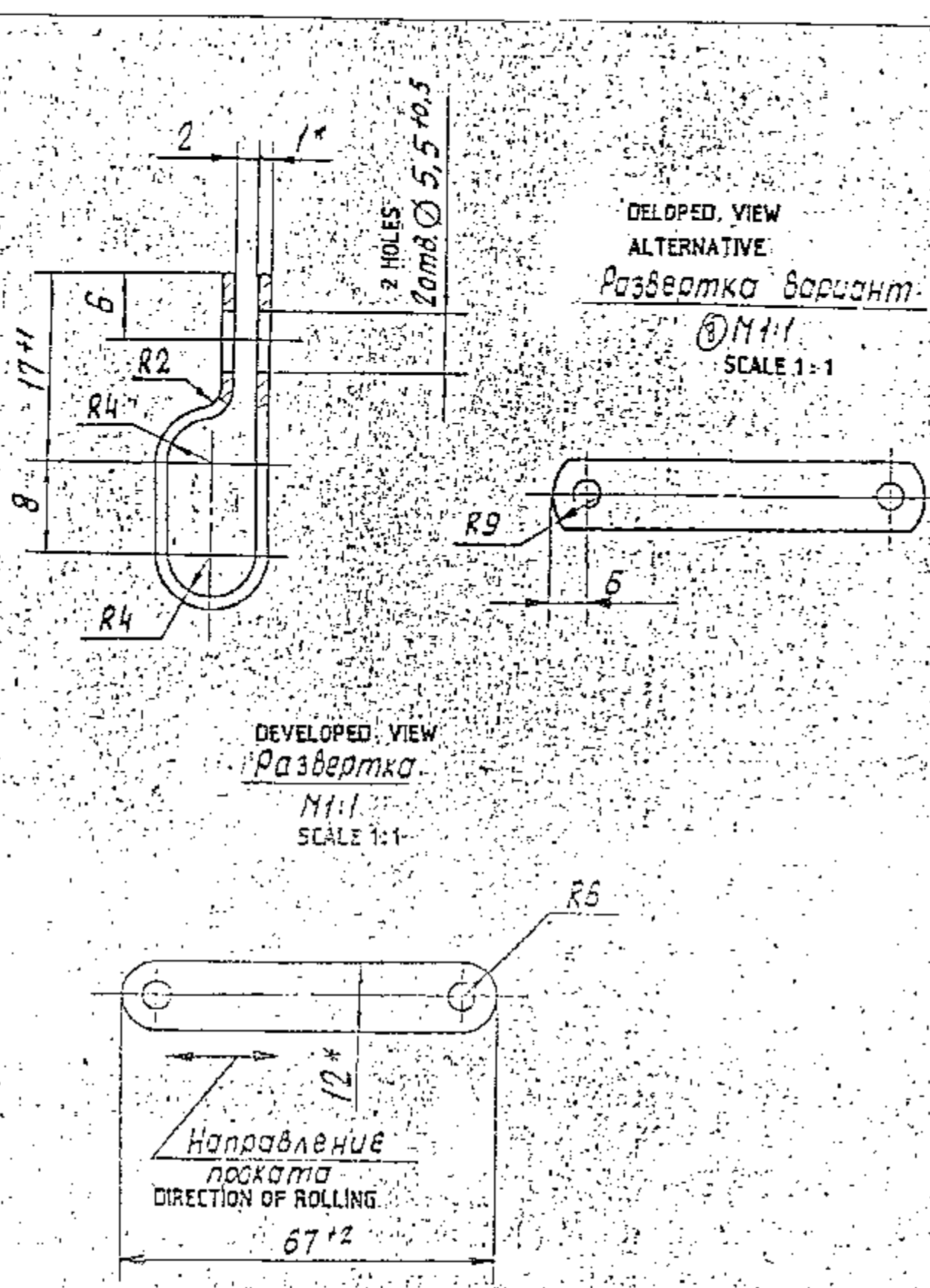

1. Заменитель материала - сталь марок 08 ; 08кп ; 10кп ГОСТ 1050-74. Допускается изготавливать из листа ГОСТ 19904-74.
 2. Требования, предъявляемые к штамповке, по нормам 82050-16.
 3. Покрытие Ц12... 24 хр по ИЛ-483-82 с удалением водородной хрупкости или лак ГФ-95 по ИЛ-09-73.
 4. В тропическом исполнении покрытие К89 хр по ИЦЛ-104 с удалением водородной хрупкости или лак ГФ-95 по ИЛ-09-73.
 5. Размеры для справок.

- 1) ALTERNATE MATERIAL - STEEL, GRADES 08; 08KP; 10KP, GOST 1050-74, MAY BE MADE FROM SHEET GOST 19904-74.
- 2) REQUIREMENTS FOR STAMPING IN ACCORDANCE WITH STANDARD 82050-16.
- 3) COATING - Zn 12... 24 CHROMATIZING, AS PER ИЛ-483-82 WITH ELIMINATION OF HYDROGEN EMBRITTLEMENT OR VARNISH ГФ-95 AS ИЛ-09-73.
- 4) IN TROPICALIZED CONSTRUCTION, COATING Z-C8 9, CHROMATIZING IN ACCORDANCE WITH ИЦЛ-104 WITH ELIMINATION OF HYDROGEN EMBRITTLEMENT OR VARNISH ГФ-95 IN ACCORDANCE WITH ИЛ-109-73.
- 5) * DIMENSIONS FOR REFERENCE.

(A) EQUIVALENT MATERIAL
Gr. DD IS: 513-1994

PILOT SAMPLE SHOULD BE APPROVED BY A H S F BEFORE BULK PRODUCTION.

EST. WT. 0,0052 Kg. TO BE STAMPED OR MARKED WHERE INDICATED THUS ≡ LETTERS)
 ALL SHARP EDGES AND CORNERS TO BE REMOVED UNLESS OTHERWISE STATED MACHINED CORNERS TO HAVE R OUTSIDE R INSIDE EQUIVALENT CHAMFERS ARE PERMISSIBLE.

DESIGN	DATE	MATERIAL	USED ON
STRIP. 080E-M-2-1x12	29-3-88	GOST 503-81	СБ 322-15-4
CONTROLLER OF QUALITY ASSURANCE (HEAVY VEHICLES)			AVADI
SCALE - 2:1		TITLE	
DIMENSIONS IN mm.		CLIP OF 2 PIPES	
TOLERANCE ON DIMS UNLESS OTHERWISE STATED IS 2102-69		S CAT. NUMBER	
ALL THREADS TO CONFORM TO		DRAWING NUMBER	
A	10.03.10	Alt. Comm. Mt. Minutes Pt. No. 101.26.10.09	322-65
ISSUE	DATE	NATURE OF AMENDMENTS	

8 322-65-114 ИЛ-09-73 ИЛ-09-73
 ИЛ-09-73 ИЛ-09-73 ИЛ-09-73 ИЛ-09-73

DRG. REDRAWN BASED ON NEW ISSUE
 DRG. INDICISED BASED ON RUSSIAN ORIGINAL ISSUE No. 8 (83-114)

KYD 66762
 A-7



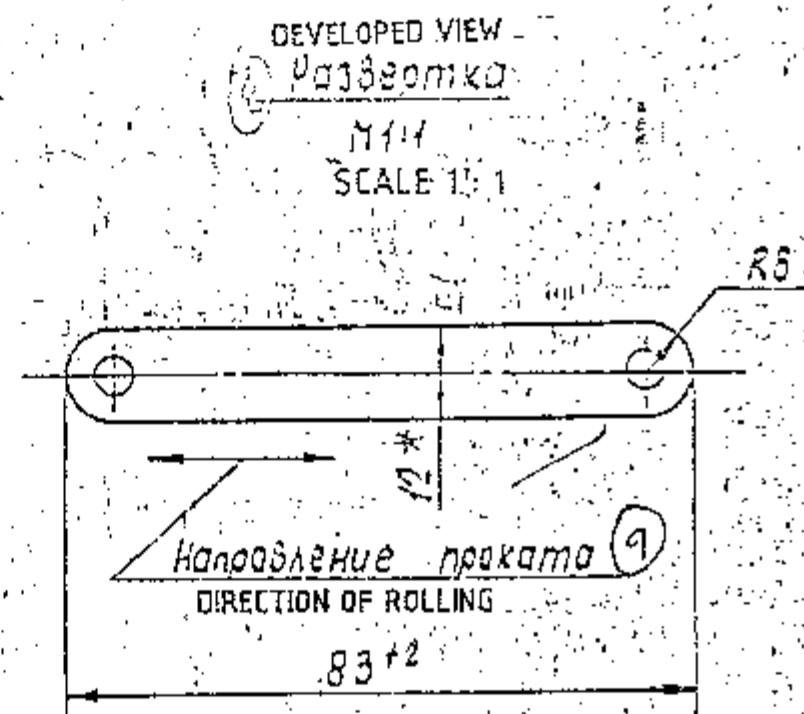
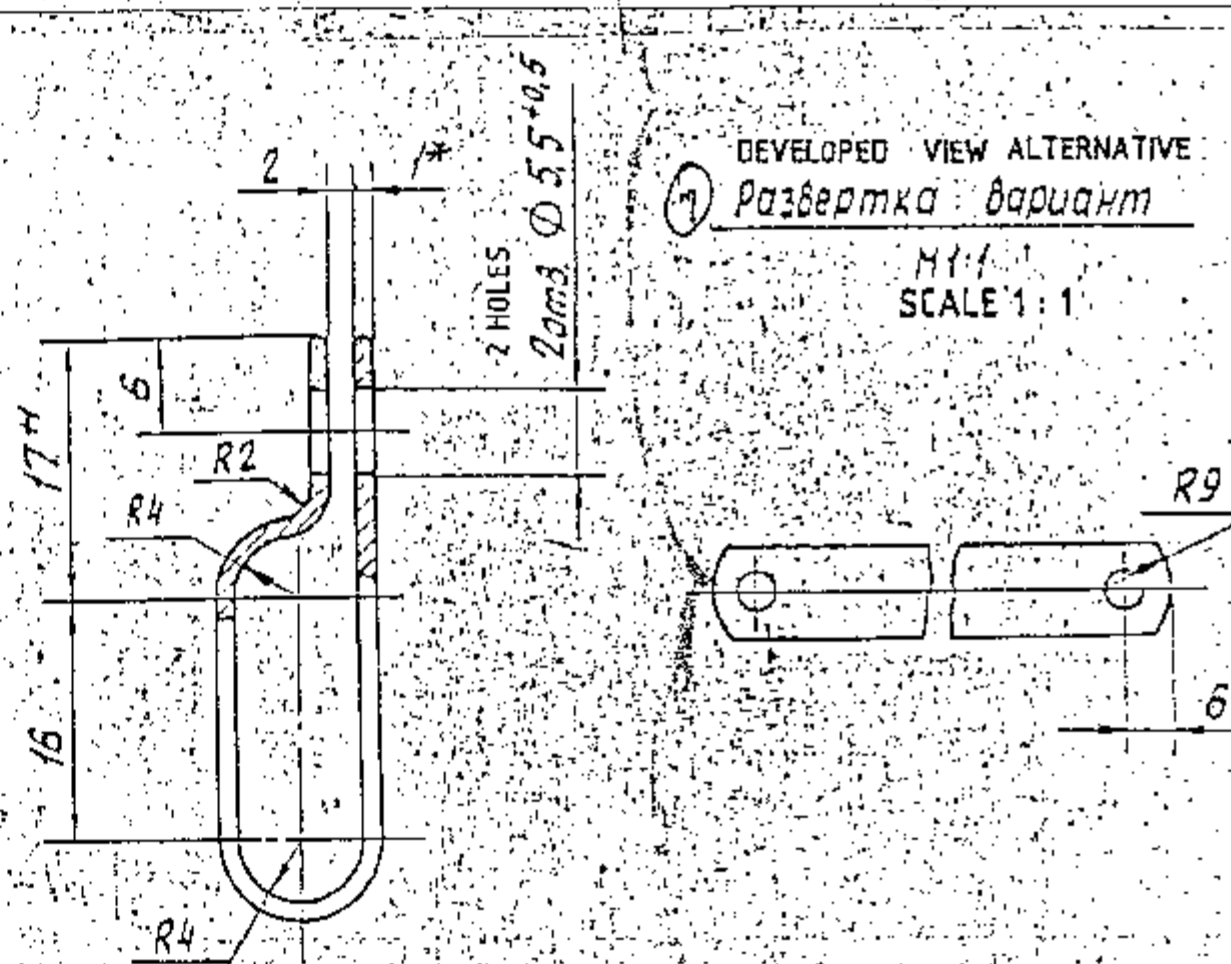

1. Заменитель материала сталь марок 08, 08кп, 10кп ГОСТ 1050-74. Допускается изготавливать из листа ГОСТ 19904-74.
2. Требования, предъявляемые к штамповке, по нормам 82050-16.
3. Покрытие Ц12...24 хр по ИЛ-483-82 с удалением водородной хрупкости или лак ГФ-95 по ИЛ-09-73.
4. В тропическом исполнении покрытие КВ9 хр по ИЦЛ-104 с удалением водородной хрупкости или лак ГФ-95 по ИЛ-09-73.
5. Размеры - для справок.

- 1) ALTERNATE MATERIAL : STEEL, GRADES 08, 08KP, 10KP, GOST 1050-74 MAY BE MANUFACTURED FROM SHEET GOST 19904-74 .
- 2) REQUIREMENTS FOR STAMPING IN ACCORDANCE WITH STANDARD 82050-16 .
- 3) COATING : Zn 12 ... 24 CHROMATIZING AS PER ИЛ - 483-82 WITH ELIMINATION OF HYDROGEN EMBRITTLEMENT OR VARNISH ГФ-95 , AS PER ИЛ -09-73 .
- 4) IN TROPICALIZED CONSTRUCTION COATING : Cd 9, CHROMATIZING IN ACCORDANCE WITH ИЦЛ -104 WITH ELIMINATION OF HYDROGEN EMBRITTLEMENT OR CLYPTAL VARNISH ГФ 95 IN ACCORDANCE WITH ИЛ-09-73 .
- 5) * DIMENSIONS FOR REFERENCE .

(A) EQUIVALENT MATERIAL
G.Y.DD IS: 513-1994

8	кон.	РЗ-714	1972	19.01
10	кон.	А.В.С.М.	1980	1.02

PILOT SAMPLE SHOULD BE APPROVED BY A H S P BEFORE BULK PRODUCTION.

EST. WT. 0,0065 Kg
TO BE STAMPED OR MARKED WHERE INDICATED THIS # LETTERS)
ALL SHARP EDGES AND CORNERS TO BE REMOVED UNLESS OTHERWISE STATED MACHINED CORNERS TO HAVE R OUTSIDE R INSIDE EQUIVALENT CHAMFERS ARE PERMISSIBLE.

DATE	19.03.10	4th Alt. Comm. Pt. Minuteg Pt. No. 1 Dt. 26.10.09	NATURE OF AMENDMENTS
ISSUE	DATE	NATURE OF AMENDMENTS	
MATERIAL :- STRIP 08ЛС-М-2-1x12 GOST 503-81		USED ON :- CB 20-35-00-5 CB 322-14-4	
SCALE :- 2:1		DIMENSIONS IN mm.	
TOLERANCE ON DIMNS UNLESS OTHERWISE STATED IS 2102-69		TITLE CLIP OF 3 PIPES	
D S CAT NUMBER		DRAWING NUMBER 322-66	

ORG. REDRAWN BASED ON NEW ISSUE.

ORG. INDIANISED BASED ON RUSSIAN ORIGINAL ISSUE No. 8 (83-114) J

A-7
SIZE: A2



DRAWING NUMBER

322-67

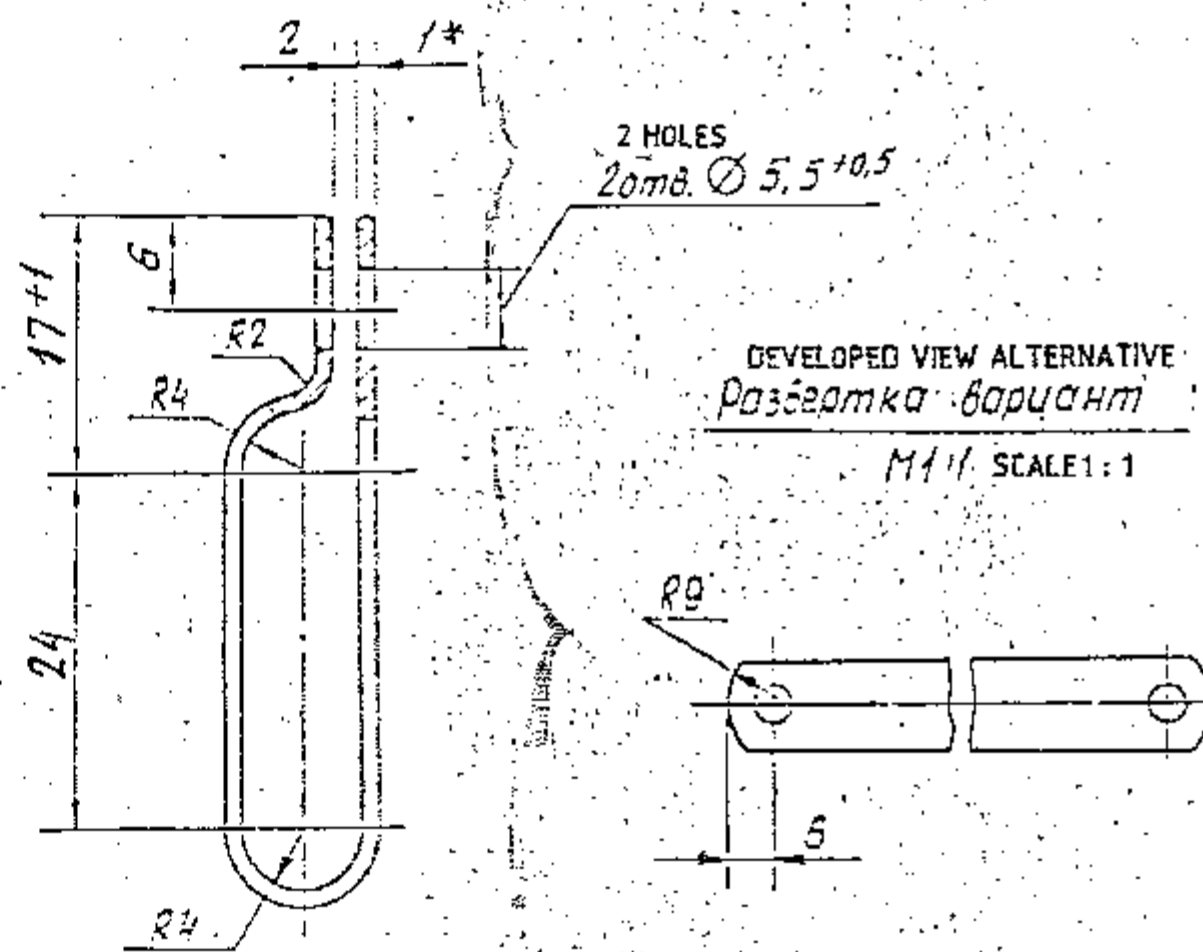

DEVELOPED VIEW
Разборка
M11 SCALE 1:1

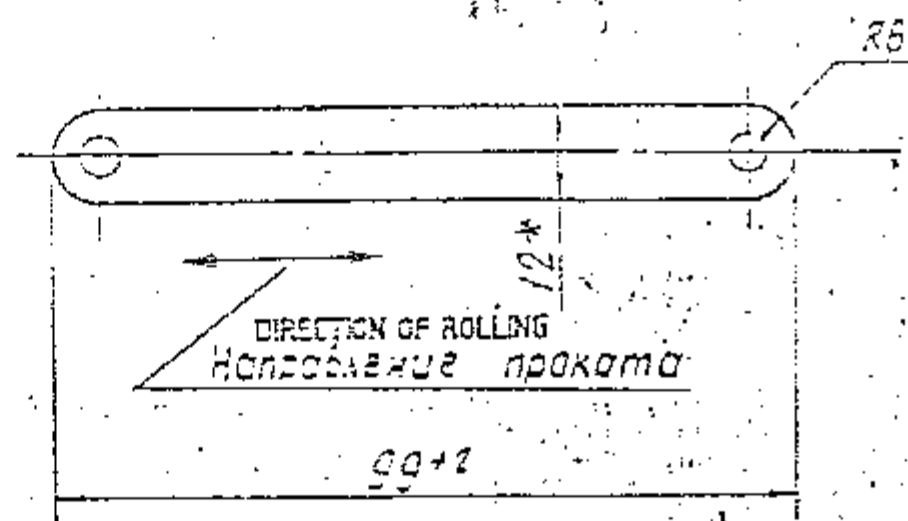

DEVELOPED VIEW
Разборка
M11 SCALE 1:1

1. Заменитель материала сталь марок 08; 08кп; 10кп ГОСТ 1050-74. Допускается изготовлять из листа ГОСТ 19904-74.

2. Требования, предъявляемые к штамповке, по нормам 82050-16.

3. Покрытие цинк... 24. хр по ИЛ-483-82 с удалением водородной хрупкости или лак ГФ-95 по ИЛ-09-73.

4. В тропическом исполнении покрытие кад 9. хр по ИЦЛ-104 с удалением водородной хрупкости или лак ГФ-95 по ИЛ-09-73.

5.* Размеры для справок.

- 1) ALTERNATE MATERIAL : STEEL, GRADES 08, 08КП, 10КП GOST 1050-74 MAY BE MANUFACTURED FROM SHEET GOST 19904-74 .
- 2) REQUIREMENTS FOR STAMPING IN ACCORDANCE WITH STANDARD 82050-16 .
- 3) COATING : Zn, 12 . . . 24, CHROMATIZING AS PER ИЛ-483-82 WITH ELIMINATION OF HYDROGEN EMBRITTLEMENT OR VARNISH ГФ - 95 AS PER ИЛ-09-73 .
- 4) IN TROPICALIZED CONSTRUCTION COATING : Cd 9, CHROMATIZING IN ACCORDANCE WITH ИЦЛ-104 WITH ELIMINATION OF HYDROGEN EMBRITTLEMENT OR GLYPTAL VARNISH ГФ - 95 IN ACCORDANCE WITH ИЛ -09-73 .
- 5) * DIMENSIONS FOR REFERENCE .

(A) EQUIVALENT MATERIAL
GrDD IS:513-1994

DRN	CHD	TCD	APFD	DATE	SCALE	DIMENSIONS IN mm	TOLERANCE ON DIMNS UNLESS OTHERWISE STATED IS 2102-69	ALL THREADS TO CONFORM TO
				127-3-8*	- 2:1			
MATERIAL :- STRIP 08ПC-M-2-1x12 GOST 503-81.							USED ON :- СБ 322-14-4 СБ 322-15-4	
CONTROLLERATE OF QUALITY ASSURANCE (HEAVY VEHICLES)							A V A D I	
TITLE							CLIP OF 4 PIPES	
D S CAT NUMBER							DRAWING NUMBER	
							322-67	
EST. WT. 0,0075 Kg.		TO BE STAMPED OR MARKED WHERE INDICATED THUS # (LETTERS)		A 10.03.10		NATURE OF AMENDMENTS		
ALL SHARP EDGES AND CORNERS TO BE REMOVED UNLESS OTHERWISE STATED MACHINED CORNERS TO HAVE R OUTSIDE R INSIDE EQUIVALENT CHAMFERS ARE PERMISSIBLE.				Alt. Comm. Mt. Minutes Pt. No. 1 Df. 24, 10, 09				

PLOT SAMPLE SHOULD BE APPROVED BY A H S P BEFORE BULK PRODUCTION.

8	10.03.10	10.03.10	10.03.10
ИИ	ИИ	ИИ	ИИ
ИИ	ИИ	ИИ	ИИ

ALL SHARP EDGES AND CORNERS TO BE REMOVED UNLESS OTHERWISE STATED MACHINED CORNERS TO HAVE R OUTSIDE R INSIDE EQUIVALENT CHAMFERS ARE PERMISSIBLE.

DRAWING BASED ON RUSSIAN ORIGINAL ISSUE No. 8.1.83-114

1-7



DRAWING NUMBER
322-68

SHEET No. 1 OF 1

ЕСКД

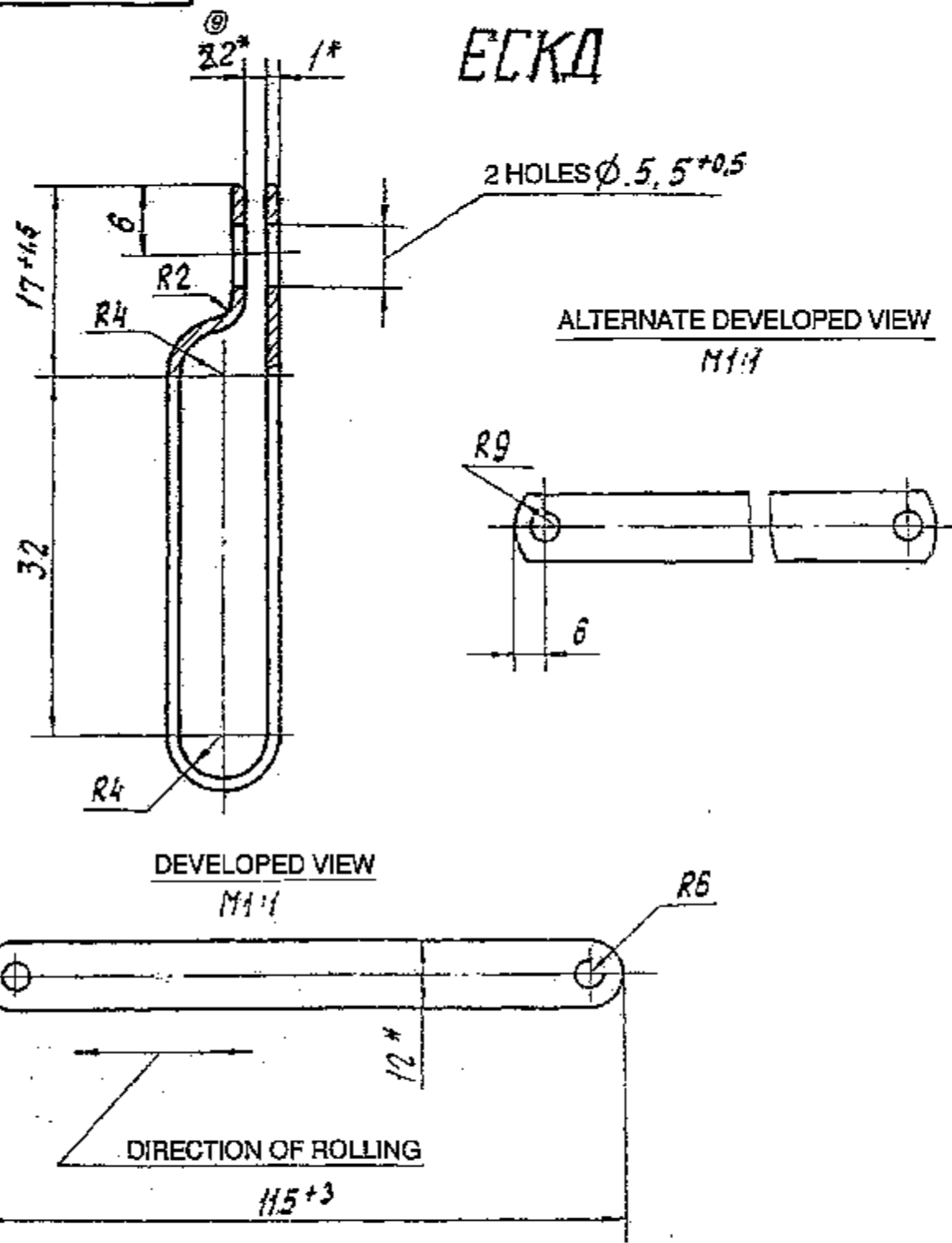

1. ALTERNATE MATERIAL : STEEL GRADES 08 КП, 10 КП, 15 КП TO GOST 1050-74.
2. REQUIREMENTS FOR STAMPING AS PER STANDARD 82050-16.
3. COATING : Zn 9, CHROMATIZING IN ACCORDANCE WITH ЦА-483-82 WITH ELIMINATION OF HYDROGEN EMBRITTLEMENT. OR Λ аКГ ϕ -95 AS PER ЦА628-86
4. IN TROPICALIZED MAKE THE COATING IS CADMIUM 9 MICRONS AS PER U 569-84 WITH REMOVAL OF HYDROGEN EMBRITTLEMENT OR Λ аКГ ϕ 95 AS PER ЦА628-86
5. * DIMENSION FOR REFERENCE.

Ⓐ EQUIVALENT MATERIAL Gr. DD
IS: 513-1994

PILOT SAMPLE SHOULD BE APPROVED BY A H S P BEFORE BULK PRODUCTION.

EST. WT. (Kg) 0.01 TO BE STAMPED OR MARKED WHERE INDICATED THUS # (LETTERS)

ALL SHARP EDGES AND CORNERS TO BE REMOVED UNLESS OTHERWISE STATED MACHINED CORNERS TO HAVE R OUTSIDE R INSIDE EQUIVALENT CHAMFERS ARE PERMISSIBLE.

DRN	Sd/=	MATERIAL :- STRIP	USED ON:- Cb 322-14-9
CIID	Sd/=	08nc-M-2-1x12 GOST 503-81	Cb 322-15-9
APPD	Sd/=	CONTROLLERATE OF QUALITY ASSURANCE (HEAVY VEHICLES) AVADI	
DATE	Nov 2010		
SCALE:- 2 : 1		TITLE :- CLIP FOR 5 PIPES	D S CAT NUMBER
DIMENSIONS IN mm			
TOLERANCE ON DIMNS UNLESS OTHERWISE STATED IS: 2102- ϕ		DRAWING NUMBER 322-68	
ISSUE	DATE		
A	13.11.10	4 th Alf. Comm. Mfg. Minutes Point No.1 Dated 26.10.09	

P. JANARDHANAN
 Dt. 15 Nov 10 JTO (D)

DRG. REINDIANISED BASED ON RUSSIAN ORIGINAL ISSUE - NIL

F-
SIZE A3

