

460  
20.50.591

FIRST ANGLE PROJECTION

unless otherwise specified  
▽4остальное

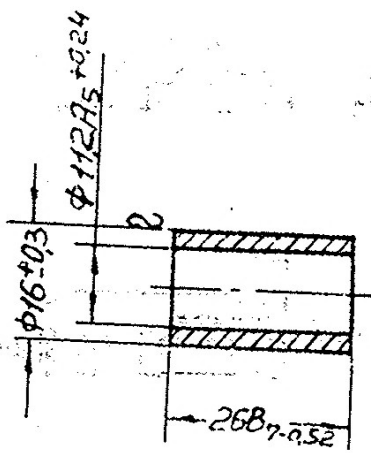

1. Допускаются на поверхности  $\phi 11,2$  риски от инструмента и черновинны
2. Допускается изготовление из трубы ~~16x3-10 ГОСТ 8734-58-А~~ <sup>16x3 ГОСТ 8734-75</sup> <sup>В10 ГОСТ 8733-74</sup>
3. Допускается изготовление из прутка  $\phi 16$  любой марки свариваемой стали.

1. Tool marks and roughspots on the surface  $\phi 11.2$  are permissible.
2. May be manufactured from tube 16X3 Gost 8734-75  
B10 Gost 8733-74
3. May be manufactured from round bar  $\phi 16$  of any grade of weldable steel.

0028-AVA		19-12-08	DS CAT No. ADDED	★	DS CAT No.	5365-181176	40001 KD	F27	
18814-W		22-10-03	HINDI NOMEN ADDED		MM	BUSH बुश	165.05.030	SHEET	1 of 1
16478-W		23-10-86	DRG SEALED		DAC				
ISSUE	DATE	REFERENCE			MATERIAL:	16X3 GOST 8734-5875	0.022	1:1	
APPROVED	<i>[Signature]</i>	3.12.88			PIPE	B 20 GOST 8733 6674	CQA(W)		
CHECKED	<i>[Signature]</i>	12.12.85			JABALPUR				
DRAWN	<i>[Signature]</i>	18.11.85							

изработано без ЛЗМ. с калёвки





172.18.074sbSB

Передпримен

Спроб. №

Подп. и дата

Миб. № одоб.

Взам. инб. №

Подп. и дата

Миб. № подл.

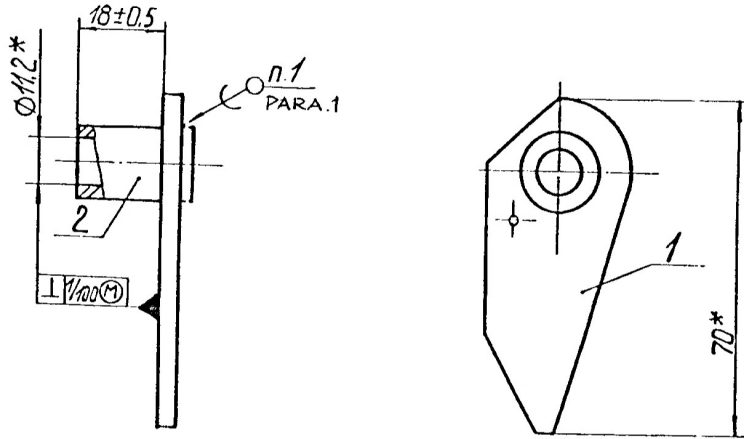

1. ПОС-40 ГОСТ 21930-76 или ГОСТ 21931-76.
2. Допускается сварка по ГОСТ 14771-76-T1-D3 в среде защитных газов.
3. \*Размеры для справок.
4. Остальные требования по 520.ТУ1.

- 1.Solder ПОС-40 GOST 21930-76 or GOST 21931-76.
- 2.Welding as per GOST 14771-76-T1-D3 in gas shielded medium is allowed.
- 3.\*Dimensions for reference.
- 4.Other requirements as per 520.TY1.

DRAWING ARE CONFIDENTIAL  
DUPLICATION / DISCLOSURE TO  
UNAUTHORISED PERSONNEL IS LIABLE  
TO INVITE PENALTIES UNDER THE INDIAN  
OFFICIAL SECRETS ACT  
BY ORDER  
Sr.GM.HVF

			172.18.074sbSB			Sup. Code	Fold. No.	Sl.no.
						U-01-1-4	93	15
			BRACKET ASSEMBLY DRAWING			Weight (kgs)	Scale	
						0.11	1:1	
						Page	Page total	
							1	
ISSUE	SHEET	REFERENCE				HEAVY VEHICLES FACTORY AVADI		
APPROVED								
CHECKED								
DRAWN								

Копировал

Формат А3

4	2	3	1
DS CAT No.			
1015-003617			

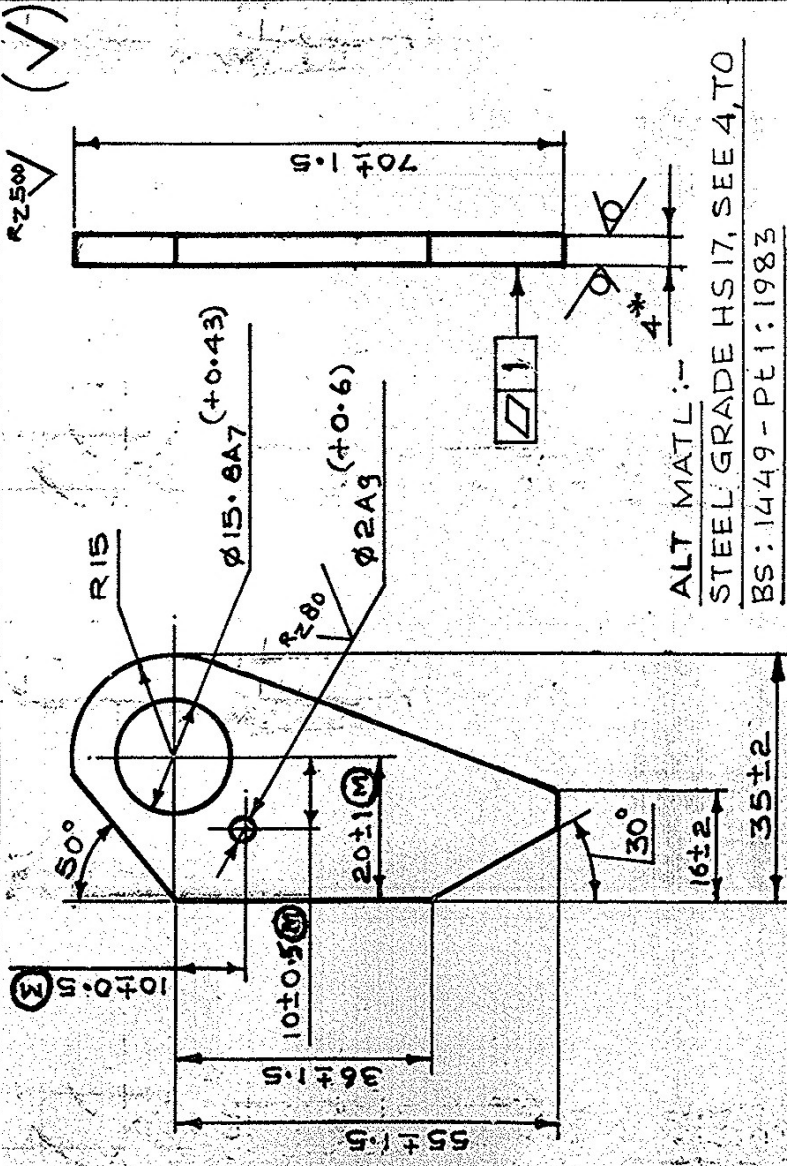

- NOTES:-
1. ALTERNATE MATERIAL SHEET 4-GOST 19903-74  
20-3-T GOST 1577-81
  2. \*DIMENSIONS FOR REFERENCE.
  3. OTHER REQUIREMENTS ARE AS PER 520 TY1.

4. MATERIAL :- 4-GOST 19903-74  
SHEET 15-3-T GOST 1577-81

22-10-83	1884-W	HINDI NEMEN ADDED	SIG AHSP	DO
14-2-94	17881-W	ALT MATL ADDED.	SIG AHSP	DO
20-5-93		RETRACED WITHOUT CHANGE	SIG AHSP	DO
		PREV DCC/D Nos. 16883 -W, & 17088 -W PT. 4.7.91	SIG AHSP	DO
DATE	AUTHOR	ZONE	NATURE	AMENDMENTS
DRG SEALED PROV:- 16883 -W 5-4-90 DO CQACW)				
SCALE:- 1:1	ESTD MASS:- 0.05	DATE:-	FOR CQACW)	
MATL:- AS SHOWN ABOVE				
ASSY DRG:-				
PART No.			DESIGN No.	
172.18.039-1			FOR CQACW)	
DS CAT No.			DESIGN No.	
1015-003617			FOR CQACW)	

RIB RIB

GROUP No. 4B  
4001 KD 57

CQAC(AVA) AVADI

DRN:- CHD:-  
TCD: D.JAMNOTA CHD:- P. Srinath  
for C/D MAN DO  
AHSP

DESIGN No.

PART No.

172.18.039-1

DS CAT No.  
1015-003617