

Section view A-A

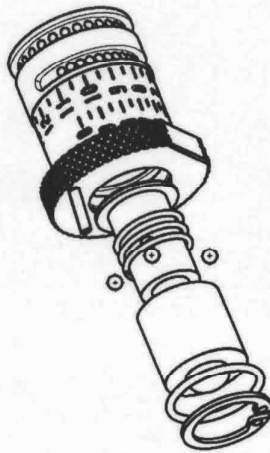

Exploded view

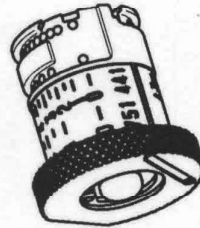

Isometric view

FOR TRADE USE  
 Date of Issue: 11/09/21  
 Review

PART NO.	DESCRIPTION	NO.	DRG.NO.
8	LUBRICATING GREASE 138 TUBE	-	MCT-3486 COA(I) 792/47
7	O-RING 18.1 x 1.6 - NBR 70	1	MCT-3485 COA(I) 792/46
6	CIRCLIP 18x1 SGH 18 SS 1582	1	MCT-3484 COA(I) 792/45
5	COMPRESSION SPRING 557	1	MCT-2304/1 COA(I) 792/4
4	BALL RB-3 RS d3	3	MCT-3483 COA(I) 792/44
3	LOCKING SLEEVE 557	1	MCT-2303/1 COA(I) 792/5
2	RETAINING KNOB 557	1	MCT-2308 COA(I) 792/6
1	KNOB & SCALE PLATE 751+441	1	MCT-3479 COA(I) 792/5A-10
		NO. OFF.	

SCHEDULE OF PARTS

(1) ALL DIMENSIONS ARE IN MILLIMETERS.  
 (2) FIRST ANGLE PROJECTION

TELESCOPIC SIGHT ASSY. 557 B14  
 KNOB 751 + 441 ASSY.

DR. P.C.SINGH  
 TR.  
 CH. APPROVED  
 (Kuldeep Saini) (S.Bhaskar)  
 JWM/D.O. AWM/EO

ORDNANCE FACTORY  
 DEHRADUN

DRG.NO  
 COA(I)792/A-4

DT. 03.11.18 SCALE: NTS  
 MATL. FINISH  
 SHEETS. 1 SHEET NO. 1  
 AMENDMENTS DRAWING NO.  
 OFD/DO/002 MCT-3478

TELESCOPIC SIGHT ASSY. 557 B 14  
LUBRICATING GREASE 138 TUBE

DRG. No.-

CQA(I)-792/47

MCT-3486

Synthetic grease that meets the requirements of  
Swedish defence standard FSD 8203

Type approved products:

- Aero Shell Grease 22
- Gulf 718 EP Synthetic Grease
- Mobil Grease 28

ORDNANCE FACTORY, DEHRADUN.

FOR TRADE USE  
Date of Issue 11/06/18 *Agreed*

		DT.-03.11.2018	SCALE-N.T.S.	
	DR.- R.K.SHARMA	MATL. AS ABOVE	FINISH AS ABOVE	
	TR.-			
	CH.	SHTS.-	SHT. NO.-	
	APPROVED.	<u>DRAWING No.-</u> <u>MCT-3486</u>		
AMENDMENTS.	(K. SAINI) <i>[Signature]</i>			(S. BHASKAR) <i>[Signature]</i>
OFD/DO/002	JWM/DO.			AWM/EO.

**TELESCOPIC SIGHT ASSY. 557 B 14**  
**O-RING 18.1×1.6-NBR 70**

DRG. No.-

CQA(I)-792/46

MCT-3485

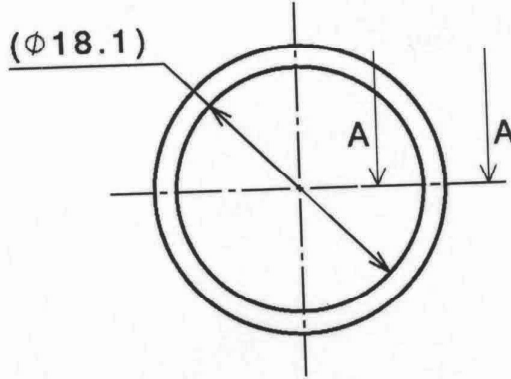

Section view A-A

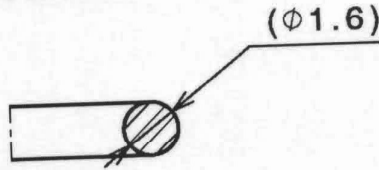

According to SS 1586

FOR TRADE COPY  
 Date of Issue 11/06/18  
*Refuse*

**MATL. :- NBR 70 ACCORDING TO SS 1587.**

NOTE :-

1. FORM & POSITION TOLERANCES ACCORDING TO ISO:1101.

(1) ALL DIMENSIONS ARE IN MILLIMETERS.  
 (2) FIRST ANGLE PROJECTION.

		DT.-03.11.2018	SCALE-N.T.S.
		MATL. AS ABOVE	FINISH AS ABOVE
		DR.- R.K.SHARMA	
		TR.-	
		CH.	SHTS.-
			SHT. NO.-
AMENDMENTS.		APPROVED.	DRAWING No.- <b>MCT-3485</b>
OFD/DO/002		(K. SAINI) JWM/DO.	
		(S. BHASKAR) AWM/EO.	

ORDNANCE FACTORY, DEHRADUN.

**TELESCOPIC SIGHT ASSY. 557 B 14**  
**CIRCLIP 18x1 SGH 18 SS 1582**

DRG. No.-  
CQA(I)-792/45

MCT-3484

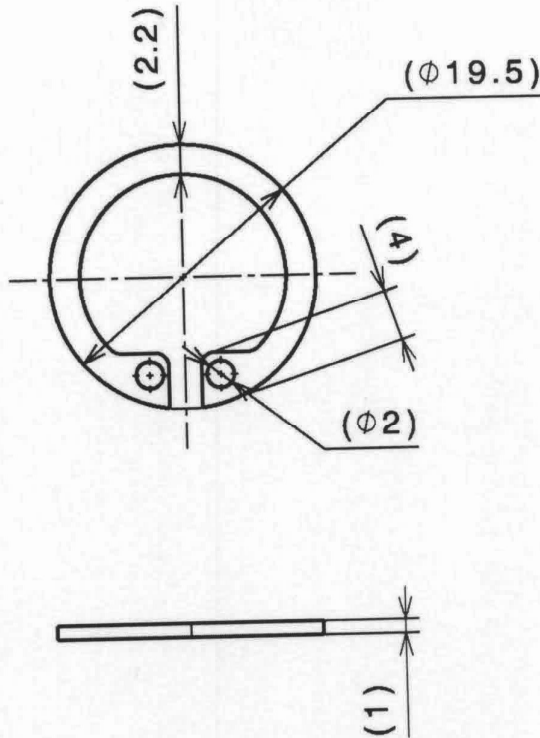

ORDNANCE FACTORY, DEHRADUN.

FOR TRADE COPY  
 Date of Issue: 11/06/18  
*Agarwal*

**MATL. :- According to SS 1582 or DIN 472 (SGH 18)**

(1) ALL DIMENSIONS ARE IN MILIMETERS. (2) FIRST ANGLE PROJECTION.		DT.-03.11.2018	SCALE-N.T.S.
	DR.- R.K.SHARMA	MATL. AS ABOVE	FINISH AS ABOVE
	TR.-	SHTS.-	SHT. NO.-
	CH.	<b>DRAWING No.-</b> <b><u>MCT-3484</u></b>	
AMENDMENTS.	APPROVED.		
OFD/DO/002	(K. SAINI) JWM/DO. (S. BHASKAR) AWM/EO.		

# TELESCOPE SIGHT 84MM CARL GUSTAV MKIII

## COMPRESSION SPRING

DRG. NO F-1302-026990

MCT-2304/1

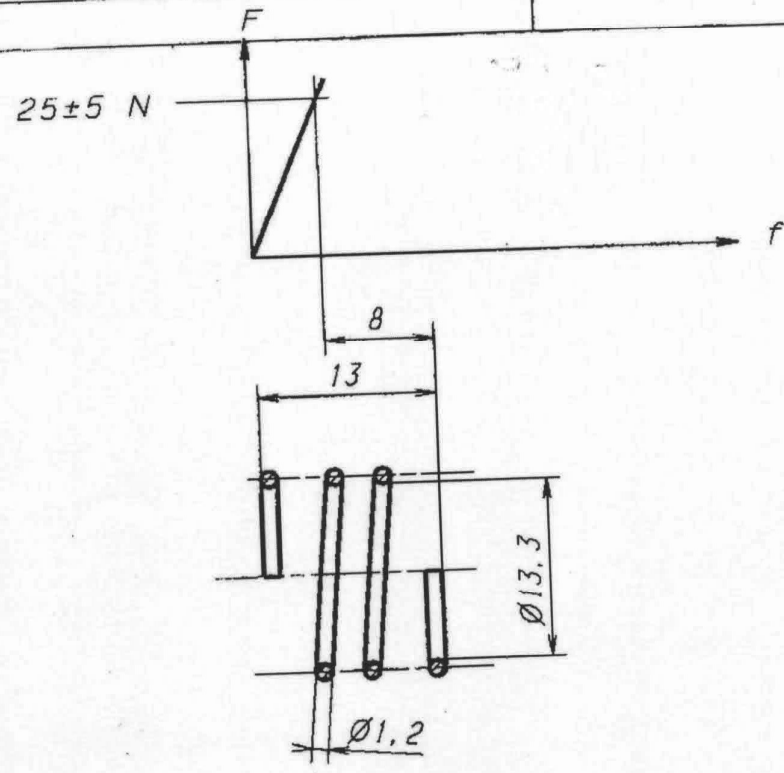

n tot  
Total number of coils | 3<sup>+0.5</sup><sub>0</sub>

Ändvarven nedlagda enl | SS 2386  
End coils squared to

MATL-15-4454-2001 Pt-1 Gde "SM"

FOR TRADE COPY  
Date of Issue 11/06/14  
Rajiv

ORD. FX DEHRA DUN

		D/-21-8-06	SCALE 2:1
	DR. SAKTI	MATL	TREAT
	TR.	-	-
DAN 18/2014 DT 16/10/14	CH. [Signature]	SHTS.	SHT. NO
AMENDMENTS	APPROVED [Signature]	DRG. NO	
OFD/DO/002	1/1/2014 DGM/P	MCT-2304/1	

TELESCOPIC SIGHT ASSY. 557 B 14  
BALL RB-3RS d3

DRG. No.-

CQA(I)-792/44

MCT-3483

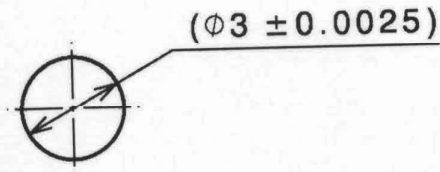

Stainless steel ball according to ISO 3290-1 / DIN 5401, ball grade G100

MATL. :- AISI 420 OR EQUIVALENT.

FOR TRADE COPY  
Date of Issue: 11/06/17  
Rajiv

(1) ALL DIMENSIONS ARE IN MILIMETERS.  
(2) FIRST ANGLE PROJECTION.

DT.-03.11.2018 SCALE-N.T.S.

	DR.- R.K.SHARMA	<u>MATL.</u> AS ABOVE	<u>FINISH</u> AS ABOVE
	TR.-		
	CH.	SHTS.-	SHT. NO.-
	APPROVED.	<u>DRAWING No.-</u> <u>MCT-3483</u>	
AMENDMENTS.	(K. SAINI)		
OFD/DO/002	(S. BHASKAR) AWM/EO.		

ORDNANCE FACTORY, DEHRADUN.

MCT-2303/1

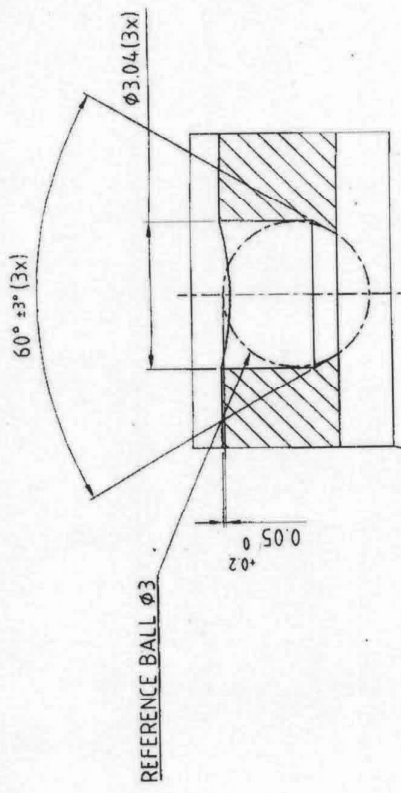

SCALE 10:1

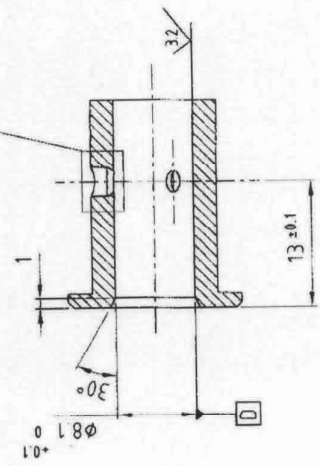

SEC. AT B-B

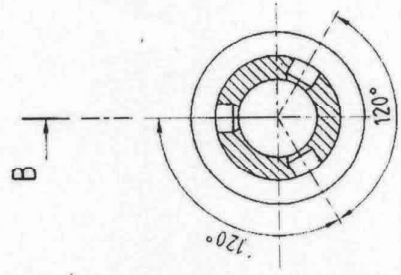

SEC. AT A-A

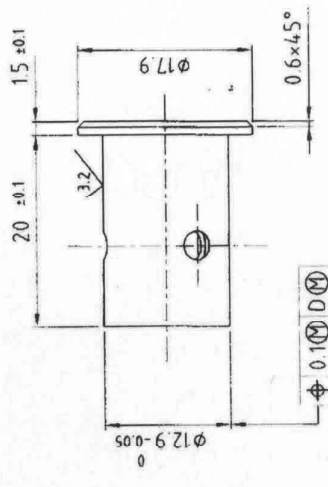

**FOR TRADE ONLY**  
 Date of Issue: 11/06/21  
 Raju

MATL: 15-4431-78 STEEL, DESIGN 40 C10 S18  
 TREAT - NITROCARBURIZED FZ min. 8µm max. 15µm, OXIDATION-TREATED.

ALL DIMENSIONS ARE IN mm.

ORDNANCE FACTORY DEHRADUN	DR- R.K.SHARMA	DT - 23.08.2006	SCALE - 2:1
	TR -	MATL: AS ABOVE	TREAT AS ABOVE
	CH - <i>Elkumar</i>	SHTS:- 1	SHT. No.:- 1
	APPROVED <i>foss</i>	<b>DRAWING NO. -</b> <b>MCT-2303/1</b>	
	IC/DO	AMENDMENTS OFD/DO/002	
	DGM/P		

TELESCOPE SIGHT FOR 84 mm. CARL GUSTAV MK-III  
LOCKING SLEEVE

DRG. No. -  
E1303-021010C