

M 9032

NOTES:

- FINISH  $\sqrt{32}$  EXCEPT AS NOTED.
- BREAK EDGES  $0.076 + 0.305$  UNLESS OTHERWISE SPECIFIED.
- HEAT TREATMENT: HEAT AT  $843 \pm 0$  TO  $871 \pm 0$  C. IN NEUTRAL ATMOSPHERE. OIL QUENCH. TEMPER 1 HOUR MINIMUM TO HARDNESS SPECIFIED (RH C49-55).
- HEAT TREATMENT IS FOR GUIDANCE, EXCEPT THAT HARDNESS AND TIME OF TEMPERING TEMPERATURE ARE MANDATORY.
- FINAL PROTECTIVE FINISH FINISH 5.3.12 OR 5.3.22 OF MIL-STD-171.
- ASME Y14.5M-1994 APPLIES.
- C/L OF -B- AT MMC.
- MATERIAL:  
 A STEEL ASTM A331 OR A322, 4140, 4340.  
 B INVESTMENT CASTING MIL-S-22141, TC4140, IC4340.  
 TENSILE TEST SHALL NOT APPLY. INSPECTION SHALL BE IN ACCORDANCE WITH CLASS 1, GRADE A OF MIL-STD-2175.
- ALL CONTOURS SHALL BE BLENDED SMOOTH AND CONTINUOUS.
- EXTRACTOR MUST OPERATE FREELY WITHIN DIMENSIONAL LIMIT SPECIFIED (0.185 MAX. FROM SURFACE -F-) WHEN INSTALLED IN BOLT ASSEMBLY P/N 6528322 TO MMC DIMENSIONS OR AN EQUIVALENT FIXTURE.

INSCRIBE PART No. 5504065 AND MANUFACTURER'S CODE IDENTIFICATION 1.575  $\pm$  0.381 HIGH X 0.127 + 0.381 DEEP

REVISIONS			
REV.	DESCRIPTION	DATE	APPROVED
A	CREATE DRAWING	3/23/2016	G. HERSBERGER

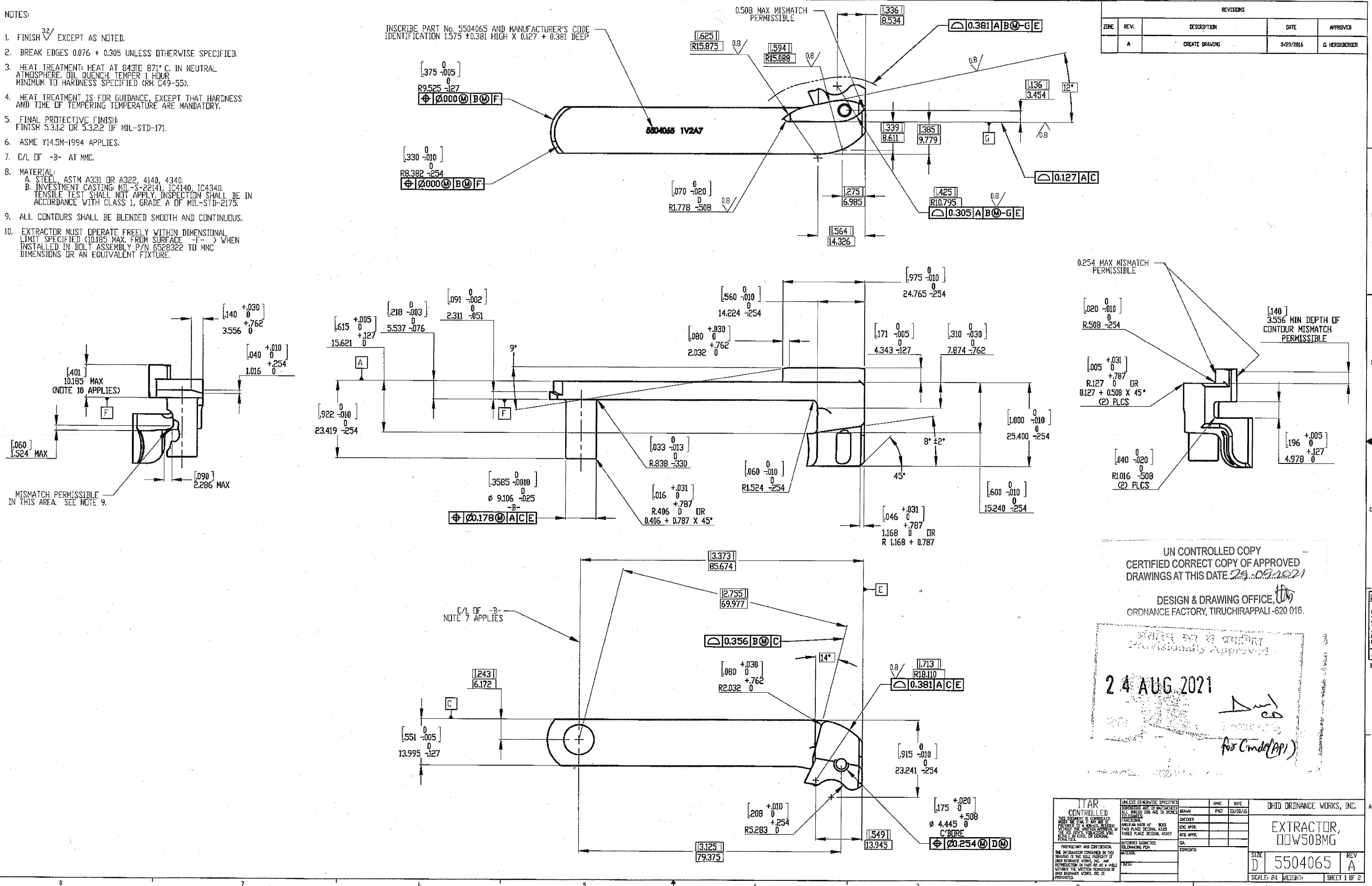

M 4022

REVISIONS				
ZONE	REV.	DESCRIPTION	DATE	APPROVED
-	-	See Sheet	-	-

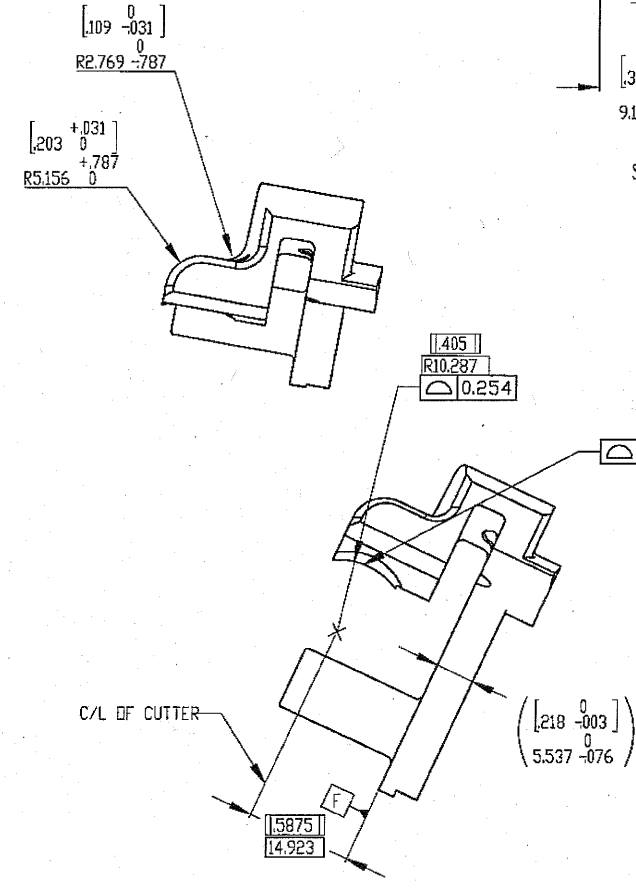
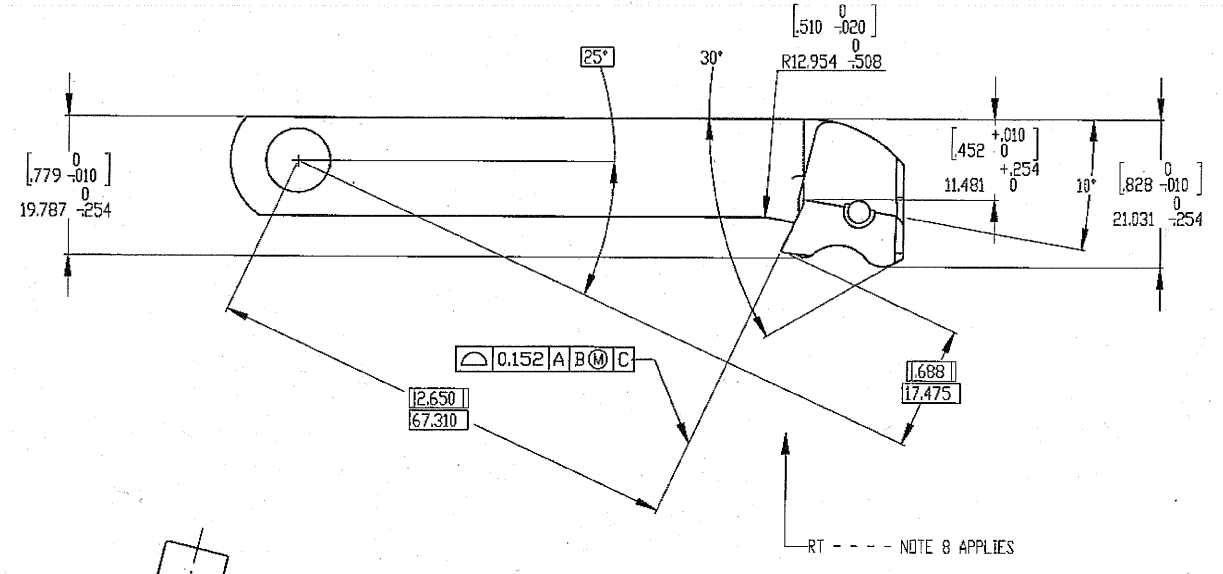
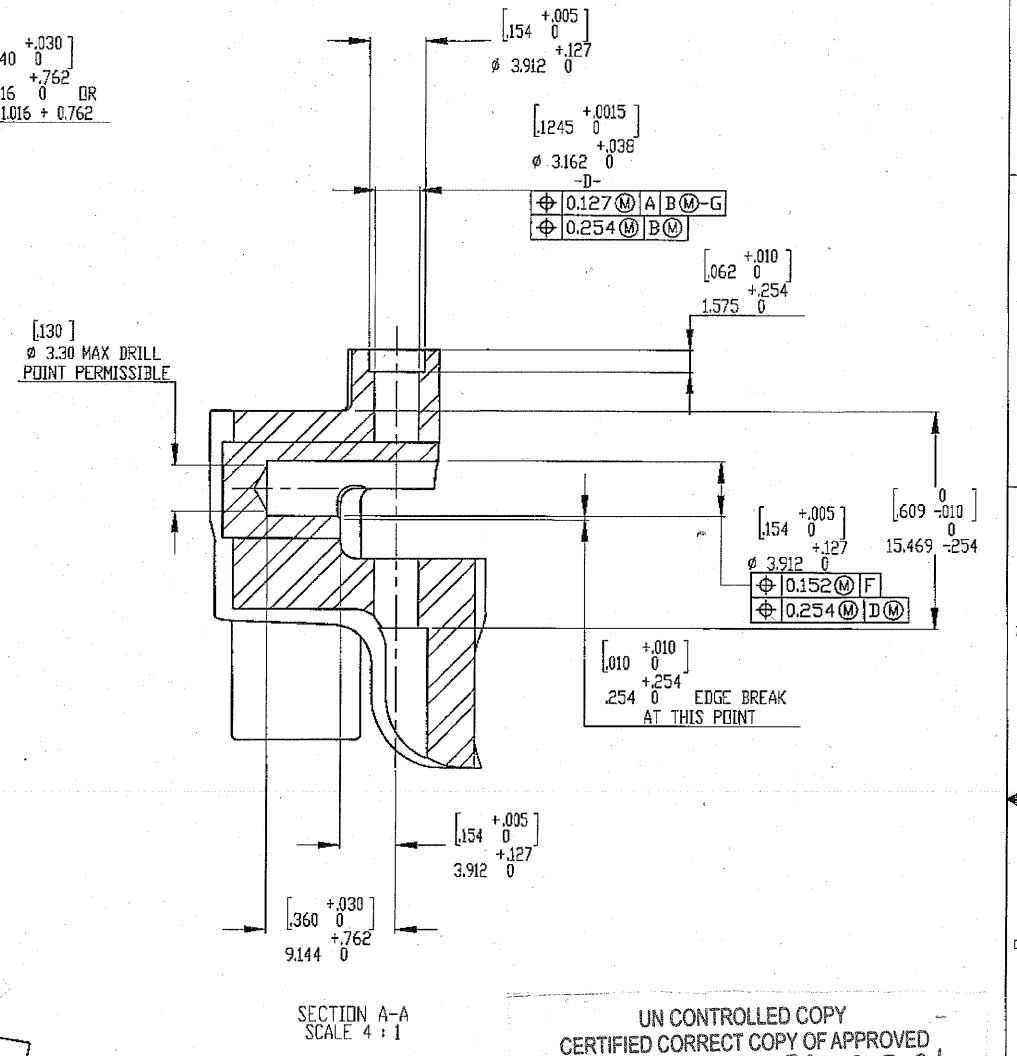
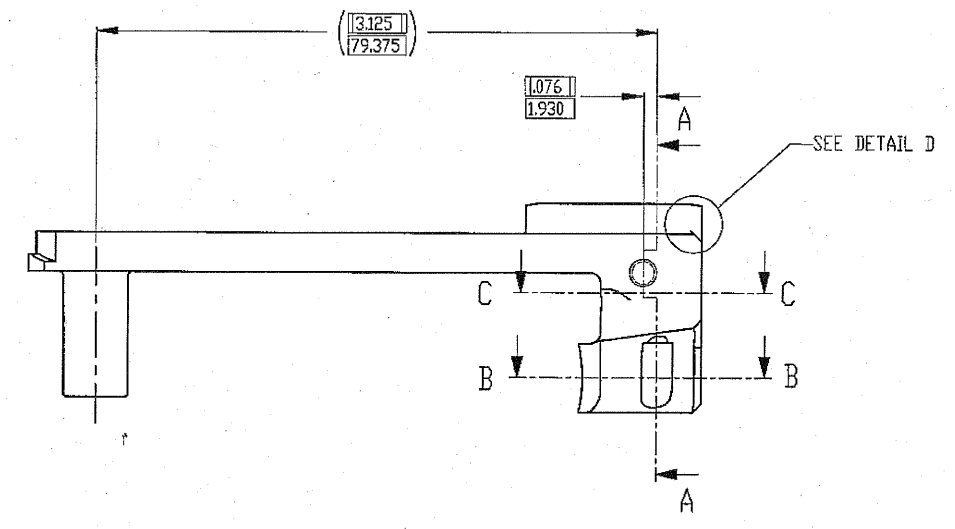
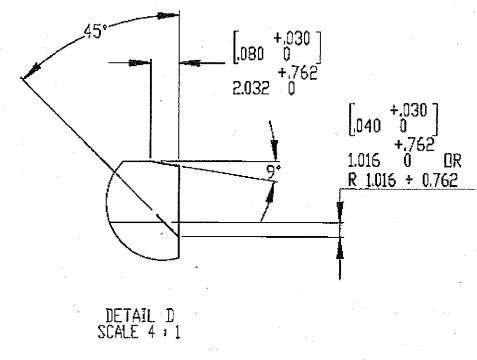
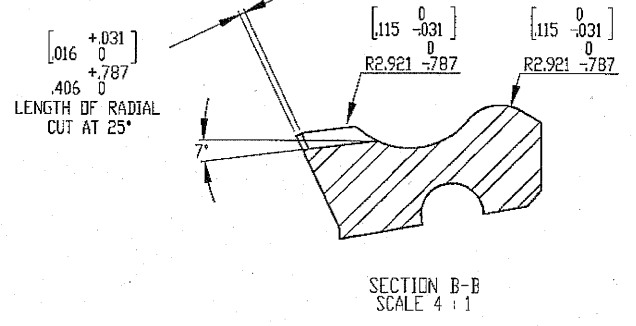
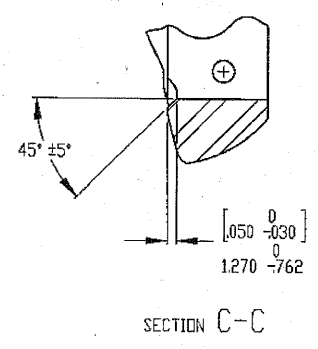

UN CONTROLLED COPY  
CERTIFIED CORRECT COPY OF APPROVED  
DRAWINGS AT THIS DATE, 29.08.2021  
DESIGN & DRAWING OFFICE,  
ORDNANCE FACTORY, TIRUCHIRAPPALI - 620 016.

अंतरिम रूप से प्रमाणित  
Provisionally Approved  
24 AUG 2021  
दिनांक हस्ताक्षर/Sig  
Asr Cmde(AM)

ITAR CONTROLLED		UNLESS OTHERWISE SPECIFIED		DATE	DATE	DATE	DATE	DATE	DATE	DATE	DATE	DATE	DATE	DATE	DATE	DATE	DATE	DATE	DATE	DATE
DESIGNED BY	CHKD BY	TEMPERATURE	FINISH	DATE	DATE	DATE	DATE	DATE	DATE	DATE	DATE	DATE	DATE	DATE	DATE	DATE	DATE	DATE	DATE	DATE
DRAWN BY	CHKD BY	TEMPERATURE	FINISH	DATE	DATE	DATE	DATE	DATE	DATE	DATE	DATE	DATE	DATE	DATE	DATE	DATE	DATE	DATE	DATE	DATE
DATE	DATE	DATE	DATE	DATE	DATE	DATE	DATE	DATE	DATE	DATE	DATE	DATE	DATE	DATE	DATE	DATE	DATE	DATE	DATE	DATE

ORDNANCE WORKS, INC.  
EXTRACTOR, BOW50BMG  
SIZE D 5504065 REV A  
SCALE 24 WEIGHT SHEET 2 OF 2

D 5504065