

1 2 3 4

ISS C A AA S SS IC DRG.No. 970700011719000000TA

GEN TOL FINE/MEDIUM/COARSE
CLASS TO IS:2102

DRG CONVENTIONS CONFIRM TO INDIAN STD
DIMN IN mm UNLESS OTHERWISE STATED

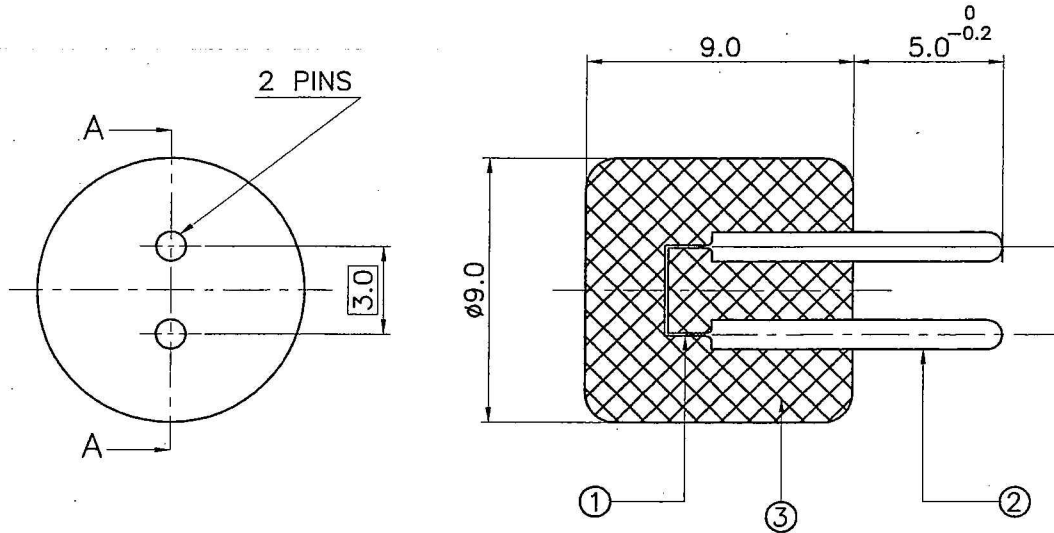

SECT: 'A' - 'A'

MATERIAL -

POLYSTYRENE MOULDING POWDER TYPE 'A' OR 'B' TO SPECN JSS 9330 - 01 : 2000
IN OLIVE GREEN COLOUR (ISC :220) OR
ABS GRADE 'A' TO SPECN IND/ME/942 (PROV) COLOUR BLACK OR EQUIVALENT

NOTE -

ITEM NO.1) COPPER WIRE 20 / 22 SWG. (LENGTH AS REQD.)
AND ITEM NO.2) PIN TO BE SOLDERED BEFORE MOULDING.

S No	DATE	AUTHORITY	BRIEF RECORD	ZONE	CD	GO
DRN TSL		CHD <i>[Signature]</i>	MATERIAL		SIGN	
APPD DATE		<i>[Signature]</i> For Director scr	AS ABOVE			
SEALED DATE	04/07/2018		PROTECTIVE FINISH			
SCALE	1:1	EST MASS	TITLE			
DESIGN AUTHORITY	ARDE		TRANSIT PLUG (FOR SQUIB CLEARING CHARGE)			
PUNE 411021						

DRG.No. 970700011719000000TA

PART No DS CAT No AHSP

1 2 3 4

DRG. CONVENTIONS CONFORM TO IS: SPECIFICATIONS
DIMENSIONS ARE IN mm.

41

GEN. TOL. MEDIUM CLASS TO IS:2102(PART 1) : 1980 (RA1991).

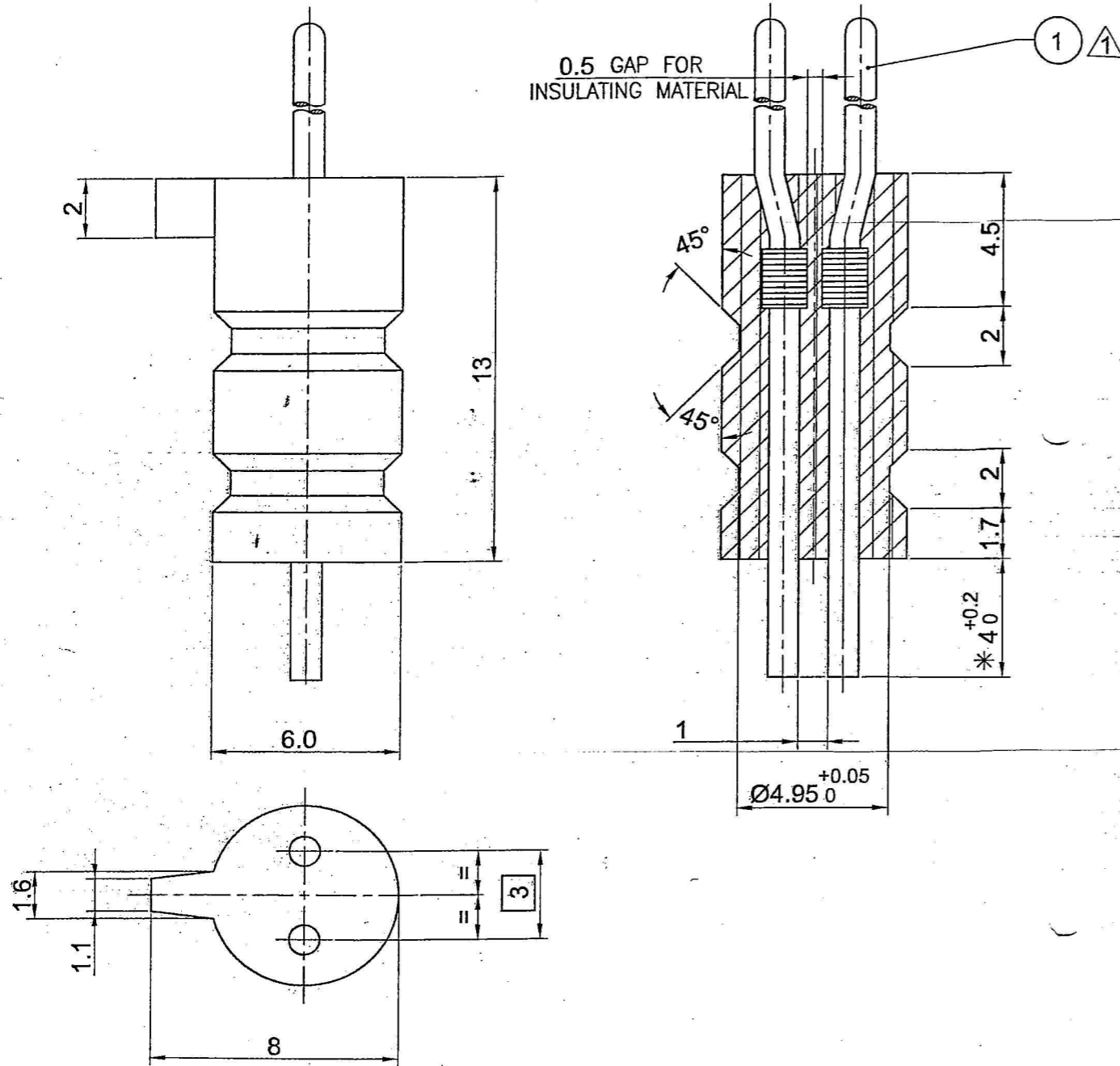

LIST OF COMPONENT				
SR. No.	DESCRIPTION	DESIGNER'S REFERANCE	PART No.	No. OFF
1	PIN (DETONATOR)	9707 00 01 05 19 001 00TA		2

NOTES :-

- ITEM NO. TO ① BE IN-SITU MOULDING.
- ELECTRICAL NON-CONTINUITY OF PINS TO BE CHECKED.
- *3. THE PINS HEIGHT BE SAME.

TECHNICAL REQUIREMENTS :- SPEC. CQA(A) 1824 (b)

MATERIAL :-

POLYSTYRENE MOULDING POWDER Gr. B TO JSS:9330-01
COLOUR OG (ISC-220) & APPENDIX 'B' TO SPEC. CQA(A)1824 (b)
OR ABS TO SPEC. IND/ ME/ 942 COLOUR BLACK

BASED ON CQA(A) DRG. IQX 97 SA

				DRN:- SNK	CHD:- APN	TRD:-	COMP:-	ASSY.DRG.
				C.D'MAN	<i>[Signature]</i> CIC D.O.	SCALE:- 5:1		
				APPD.	<i>[Signature]</i> OR DIR. ARDE	EST.MASS:-		
1			ITEM No.1 DRG. REVISED	F-5		GAUGE SCHD:-		DESIGNER'S REF.
R. NO.	DATE	AUTHORITY	REVISION	ZONE	AHSP D.O. SIG.	MATL:- AS ABOVE		ARDE 9707 00 01 05 19 000 00TA
DRG. SEALED:-						PROTECTIVE FINISH:-		PART NO.
								D.S. CAT NO.
								AHSP: ARDE, PUNE

SQUIB PLUG (EMPTY) FOR DETONATOR

1 2 3 4

ISS C A AA S SS IC DRG.No. 9707001719001000TA

GEN TOL FINE/MEDIUM/COARSE CLASS TO IS:2102 DRG CONVENTIONS CONFIRM TO INDIAN STD DIMM IN mm UNLESS OTHERWISE STATED

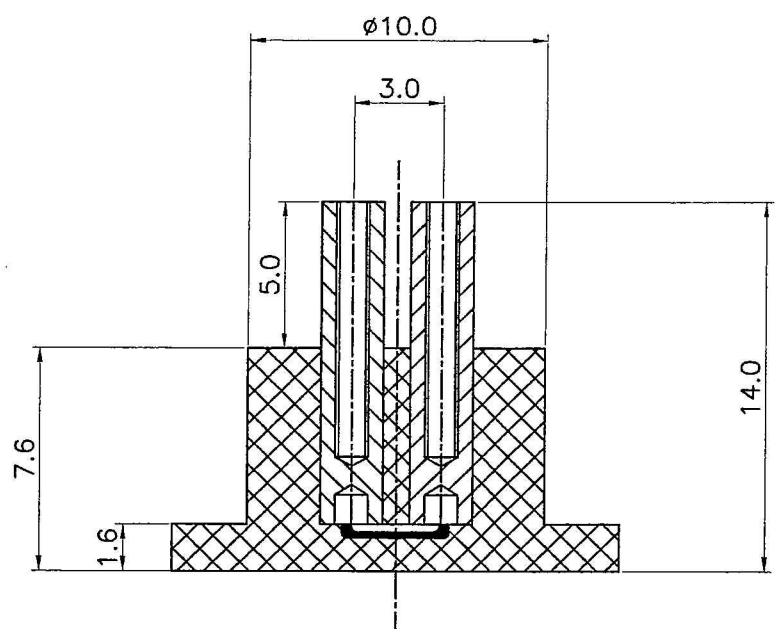

LIST OF COMPONENTS

SR NO	DESCRIPTION	DRAWING NO	QTY
1	SOCKET FOR PROTECTIVE CAP	9707 00 01 17 19 000 00TA	1
2	COPPER WIRE OF 22/22 SWG (6MM LONG) TO BE SOLDERED		

NOTE -
ITEM NO.1) COPPER WIRE 20 / 22 SWG. (LENGTH AS REQD.)
AND ITEM NO.2) PIN TO BE SOLDERED BEFORE MOULDING.

S No	DATE	AUTHORITY	BRIEF RECORD	ZONE	CD	GO
DRN SMS		CHD <i>[Signature]</i>	MATERIAL :		SIGN	
APPD DATE		<i>[Signature]</i> For Director	POLYSTYRENE MOULDING POWDER TYPE 'A' OR 'B' TO SPECN JSS 9330 - 01 : 2000 IN OLIVE GREEN COLOUR (ISC :220) OR ABS GRADE 'A' TO SPECN IND/ME/942 (PROV) COLOUR BLACK OR EQUIVALENT			
SEALED DATE		84-10/1/2018	PROTECTIVE FINISH			
			TO BE SILVER PLATED TO SPECN IS:5925 -2006			
SCALE 1:1		EST MASS	TITLE			
DESIGN AUTHORITY ARDE PUNE 411021			PROTECTIVE CAP FOR SQUIB PLUG DETONATOR			

DRG.No. 9707001719001000TA
IC SS S AA A C SST
PART No DS CAT No AHSP

1 2 3 4