

DRG. NO: FS-2935

A M E N D M E N T S

TOL.ON UN TOL. DIMENTIONS
 FOR ONE DECIMAL PLACE ± 1.3
 FOR TWO OR MORE DECIMAL PLACES ± 0.13

REV	DATE	DESCRIPTION	SIGN

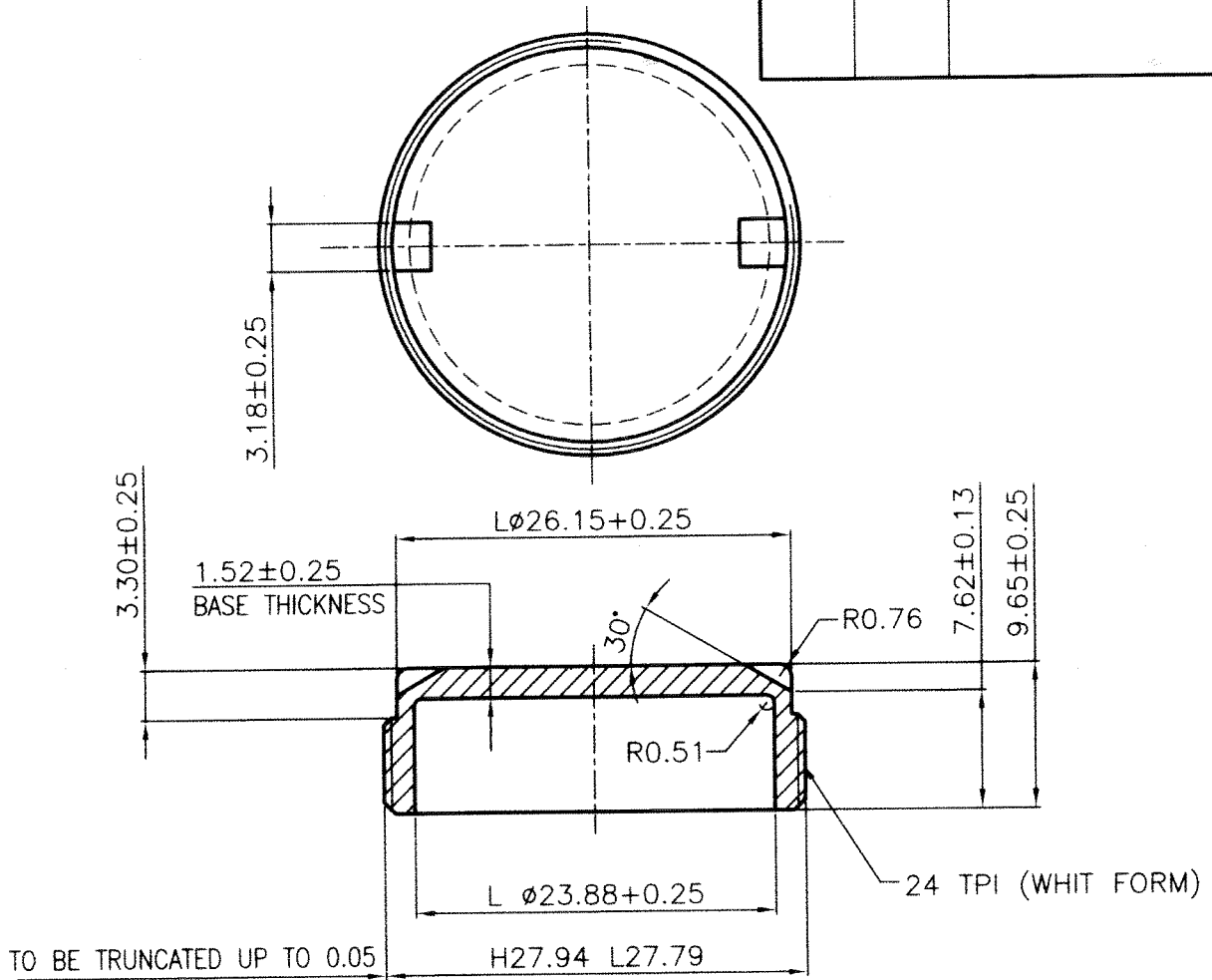

NOTE:

THOUGH SURFACE TREATMENT IS NOT TO BE DONE, SURFACE OF THE COMPONENT SHOULD BE PROPERLY PROTECTED TO AVOID DAMAGE DURING TRANSIT & STORAGE.

MATERIAL:

BRASS BS 2872-CZ 122 OR BS 2874-CZ 121 Pb3 CONDITION 'M'(LATEST ISSUE) OR BS 2870 CZ 107 IN 'O' OR 1/4 H CONDITION.

DIMENSIONS ARE IN mm			MATERIAL AS ABOVE	ऑर्डनेंस फैक्टरी अम्बाझरी	
THIRD ANGLE PROJECTION				ORDNANCE FACTORY AMBAZHARI	
SCALE - 1:1			NOMENCLATURE MAGAZINE (WITHOUT SURFACE TREATMENT)	DRAWING NO. FS-2935	
2010	NAME	DATE		SHEET NO. - 1	
DRAWN	<i>[Signature]</i>			NO.OF SHEETS - 1	
TRACED				OPERATION -	
CHECKED	<i>[Signature]</i>			COMPT.	
JWM/CDD	<i>[Signature]</i>	23/01	STORE FUZE 162	IQX-12	
APPVD	Jt.GM/FS	<i>[Signature]</i>			