

ENLARGED VIEWS  
ABOVE A-A

HOS | MPM

भारतीय प्रति / CERTIFIED COPY OF  
 शिवांग / लेआउट/ गेज निडरूत  
 DRG/LAYOUT/GAUGE SCHEDULE  
 तिनाक / AT THIS DATE. 15.06.2017  
 पी डी सी / CDD (R)  
 राइफल फैक्टरी, इशापुर  
 RIFLE FACTORY, ISHAPUR

**LEVER TRIPPING**

(THROUGH MIM ROUTE)

DRG. REF. NO. - D.S.CAT 5340-016094

DRG. NO. - REL.SK 10122

PAGE-1/3

MATERIAL : AISI / SAE 4340, MIM 4340 OR EQUIVALENT  
 HARDNESS : 82-86 HR 15N  
 SUPPLY CONDITION : MANGANESE PHOSPHATED

NOTE:- 1. ALL DIMENSIONS ARE IN MM.  
 2. GENERAL TOLERANCES ARE AS PER ISO 2768 (M).

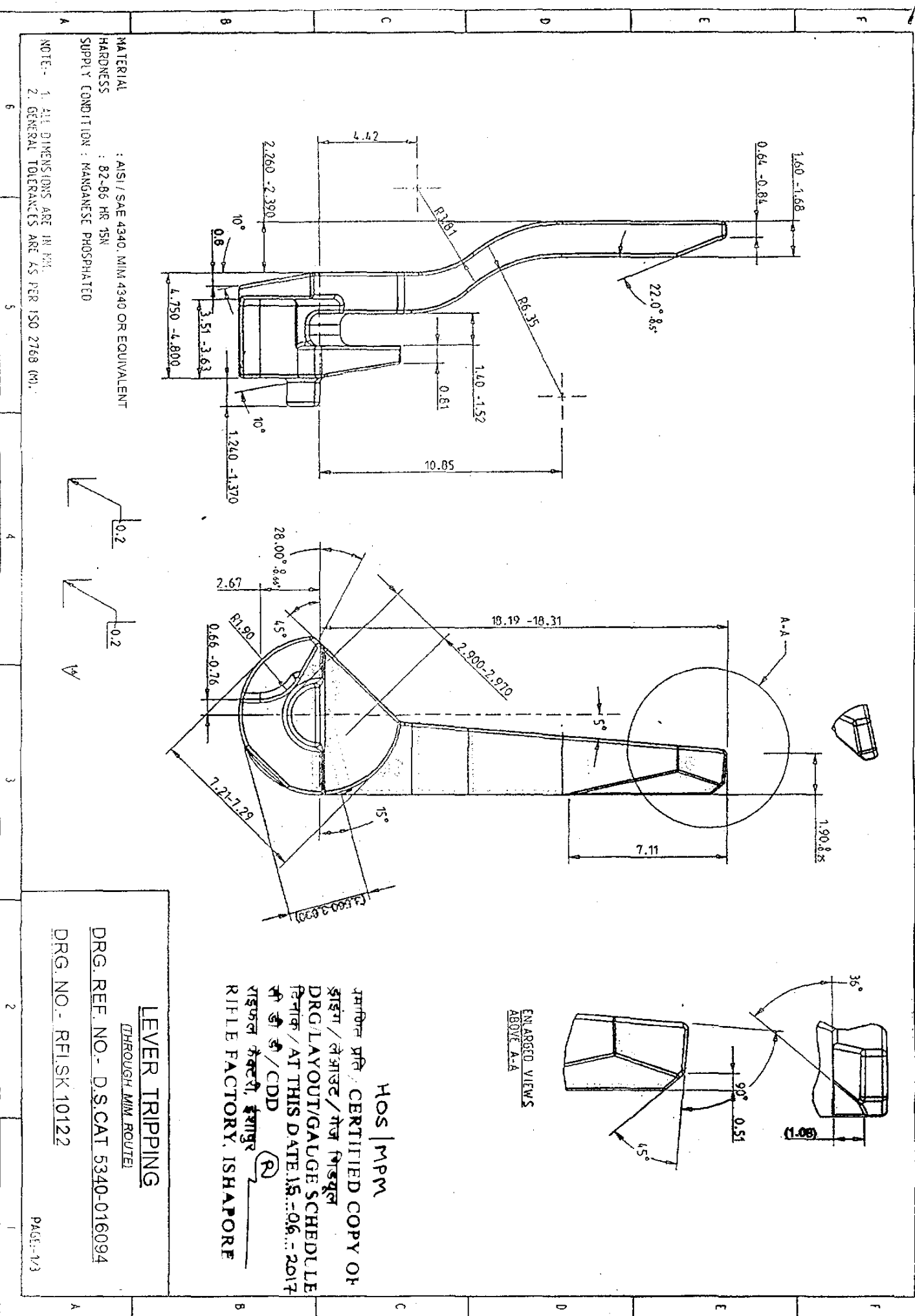

PARTING SURFACE

EJECTOR PIN MARKS  
DEPRESSION 0.1 MAX.

PIN MARKS  
DEPRESSION 0.1 MAX.

PARTING LINE MARKS  
MISMATCH 0.05 MAX.  
(WILL BE WITHIN THE  
TOLERANCE SPECIFICATION)

MANUFACTURING ID MARK  
AS "1"  
DEPRESSION 0.2 MAX.

SHARP EDGE REQUIRED  
FOR EASY MANUFACTURING

SLIDE LINE MARKS  
MISMATCH 0.05 MAX.  
(WILL BE WITHIN THE  
TOLERANCE SPECIFICATION)

MIM PROCESS ID MARK  
AS "M" DEPRESSION  
0.2 MAX

YEAR ID MARK AS "16"(2016)  
DEPRESSION 0.2 MAX.

CAVITY ID MARK AS "12"....  
DEPRESSION 0.2 MAX.  
(APPLICABLE FOR MULTI CAVITY)

DETAIL A  
SCALE 16,000

GATE MARK DEPRESSION  
0.2 MAX./PROTRUSION NOT  
ABOVE THE SURFACE "A"

SURFACE "A"

NOTES:-  
VOLUME OF THE PART = 0.192 CC  
MINIMUM WALL THICKNESS = 0.65mm

### LEVER TRIPPING

(THROUGH MIM ROUTE)

DRG. REF. NO. - D.S.CAT 5340-016094

DRG. NO. - REFSK 10122

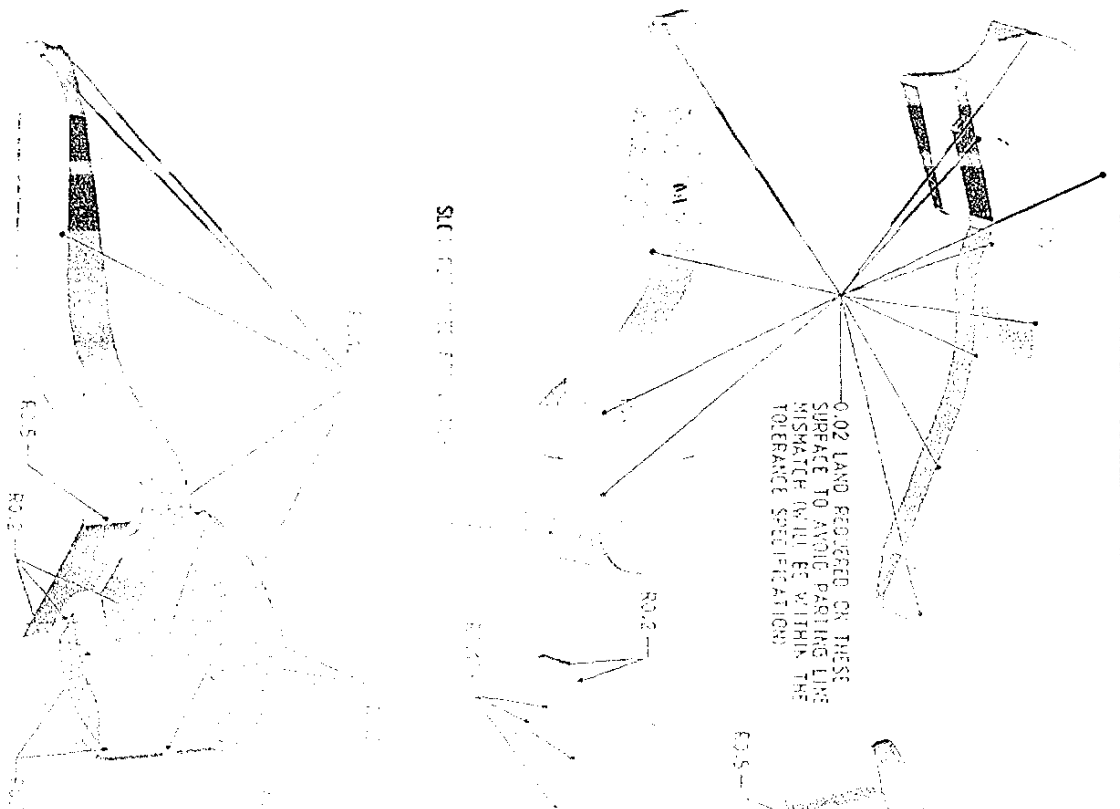

0.02 LAND REQUIRED OR THESE SURFACE TO AVOID PARTING LINE MISMATCH (WILL BE WITHIN THE TOLERANCE SPECIFICATION)

SHARP EDGE REQUIRED EASY HANDACTUATING

DETAIL E SCALE 20:000

0.02 MISMATCH LAND

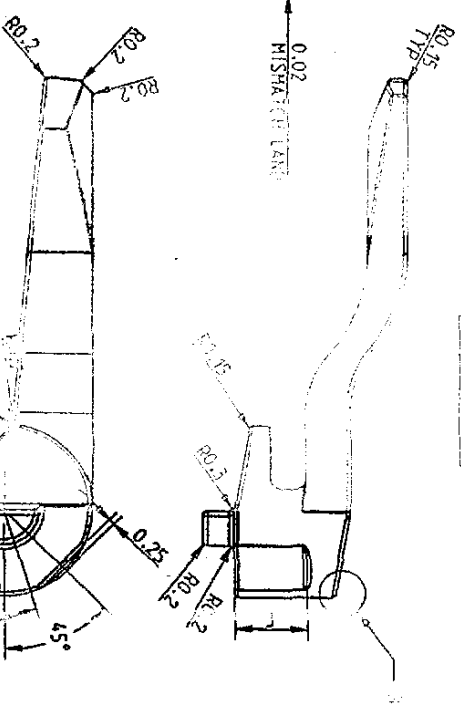
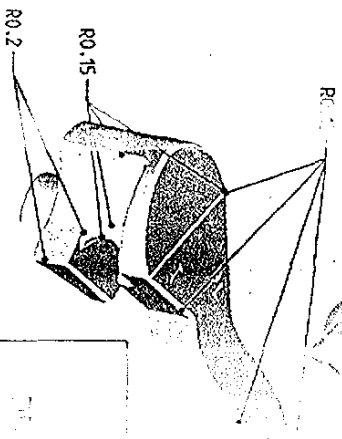

SECTION FOR GATE

**LEVER TRIPPING**

DETAILS AND NOTES

REF. NO. - D.S. CAT. 5340-016094

NO. 145 SK 1110

