

DIMENSIONS ARE IN mm.  
 UNTOLERATED DIMNS. AS PER IS : 2102 (MED)

QM CONTROLLED COPY

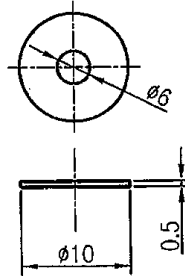

1612-8

MATERIAL:- BS 1449 Pt.1:1983 Gr. CS50  
 BS 1449 Pt.1:1983 Gr. CS80  
 IS 2507-1975 Gr.2 5506  
 IS 2507-1975 Gr.6 8006

1		1					
PART NO.	DESCRIPTIONS	NO OFF	MATERIAL	TREATMENT	REMARKS		
	SIGNATURE & DATE.	SUB: WASHER BUTTON (SLING ASSY.)			SCALE NTS		
TRACED		FOR: BAYONET ASSY.			STORE DRG.NO. K		
DRAWN		OF: TRICHY ASSAULT RIFLE			OPERATION NO.		
CHECKED		DES.REF.NO.					
HOS/D&DO	<i>P. Jay L</i>	DRG. No.: <b>TAR-K-9068</b>					
OFFICER/PRD.N.		ORDNANCE FACTORY TIRUCHIRAPPALLI-16.			SHEETS: 01		
OFFICER/D&DO	<i>Ge K</i>				SHEET No.: 01		
AMENDMENTS	SIG. & DATE	APPROVED ON.	.07.2018				

UN CONTROLLED COPY

DIMENSIONS ARE IN mm.  
 UNTOLERATED DIMNS. AS PER IS : 2102 (MED)

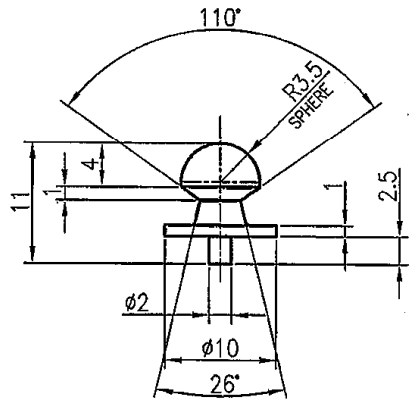

1011-16  
*[Handwritten signature]*

MATERIAL:- BS 970 Pt.1 1983 SEC.3 Gr.070 M20 (En3A,3C)  
 BS 970 Pt.1 1983 Gr.080 M40 (En8)  
 IS 7887-1992 Gr. 8 or 9

1		1			
PART NO.	DESCRIPTIONS	NO OFF	MATERIAL	TREATMENT	REMARKS
⊕	SIGNATURE & DATE.	SUB: BUTTON (SLING ASSY.)		SCALE NTS	
TRACED		FOR: BAYONET ASSY.		STORE DRG.NO. K	
DRAWN		OF: TRICHY ASSAULT RIFLE		OPERATION NO.	
CHECKED		DES.REF.NO.			
HOS/D&DO	<i>R. J. [Signature]</i>	DRG. No.: <b>TAR-K-9067</b>			
OFFICER/PRODN.		 ORDNANCE FACTORY TIRUCHIRAPPALLI-16.		SHEETS: 01	
OFFICER/D&DO	<i>G. K. [Signature]</i>			SHEET No.: 01	
AMENDMENTS	SIG. & DATE	APPROVED ON.	.07.2018		

DIMENSIONS ARE IN mm.  
 UNTOLERATED DIMNS. AS PER IS : 2102 (MED)

UN CONTROLLED COPY

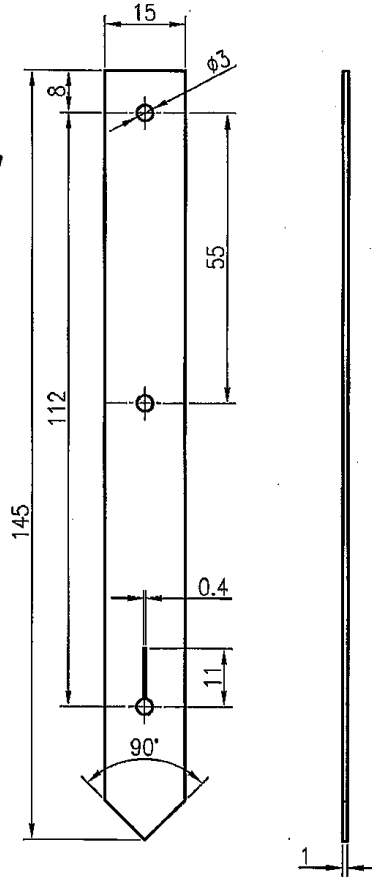

MATERIAL:- LEATHER

1		1			
PART NO.	DESCRIPTIONS	NO OFF	MATERIAL	TREATMENT	REMARKS
⊕	SIGNATURE & DATE.	SUB: STRAP 15mm WIDE FOR: BAYONET ASSY. (SLING ASSY.)			SCALE NTS
TRACED		OF: TRICHY ASSAULT RIFLE			STORE DRG.NO. K
DRAWN		DES.REF.NO.			OPERATION NO.
CHECKED		DRG. No.: <b>TAR-K-9066</b>			
HOS/D&DO	<i>P. Jaya</i>	ORDNANCE FACTORY TIRUCHIRAPPALLI-16.			SHEETS: 01
OFFICER/PRODN.					SHEET No.: 01
OFFICER/D&DO	<i>G. K. a</i>	APPROVED ON.	.07.2018		
AMENDMENTS	SIG. & DATE				

DIMENSIONS ARE IN mm.  
 UNTOLERATED DIMNS. AS PER IS : 2102 (MED)

UN CONTROLLED COPY

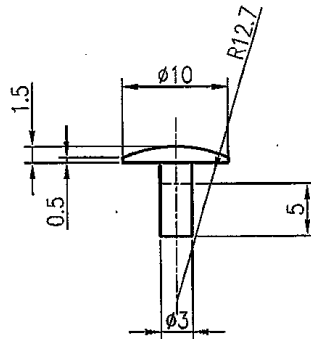

UN CONTROLLED COPY  
 ID: 11-8-2018  
 [Handwritten signature]

MATERIAL:- BS 970 Pt.1 1983 SEC.3 Gr.070 M20 (En3A,3C)  
 BS 970 Pt.1 1983 Gr.080 M40 (En8)  
 IS 7887-1992 Gr. 8 or 9

1	2	3	4
PART NO.	DESCRIPTIONS	NO OFF	MATERIAL TREATMENT
	SUB: RIVET STRAP (SLING ASSY.)		REMARKS
	FOR: BAYONET ASSY.		SCALE NTS
	OF: TRICHY ASSAULT RIFLE		STORE DRG.NO. K
	DES.REF.NO.		OPERATION NO.
	DRG. No.: <b>TAR-K-9065</b>		SHEETS: 01
	 <b>ORDNANCE FACTORY TIRUCHIRAPPALLI-16.</b>		SHEET No.: 01
AMENDMENTS	SIG. & DATE	APPROVED ON. .07.2018	

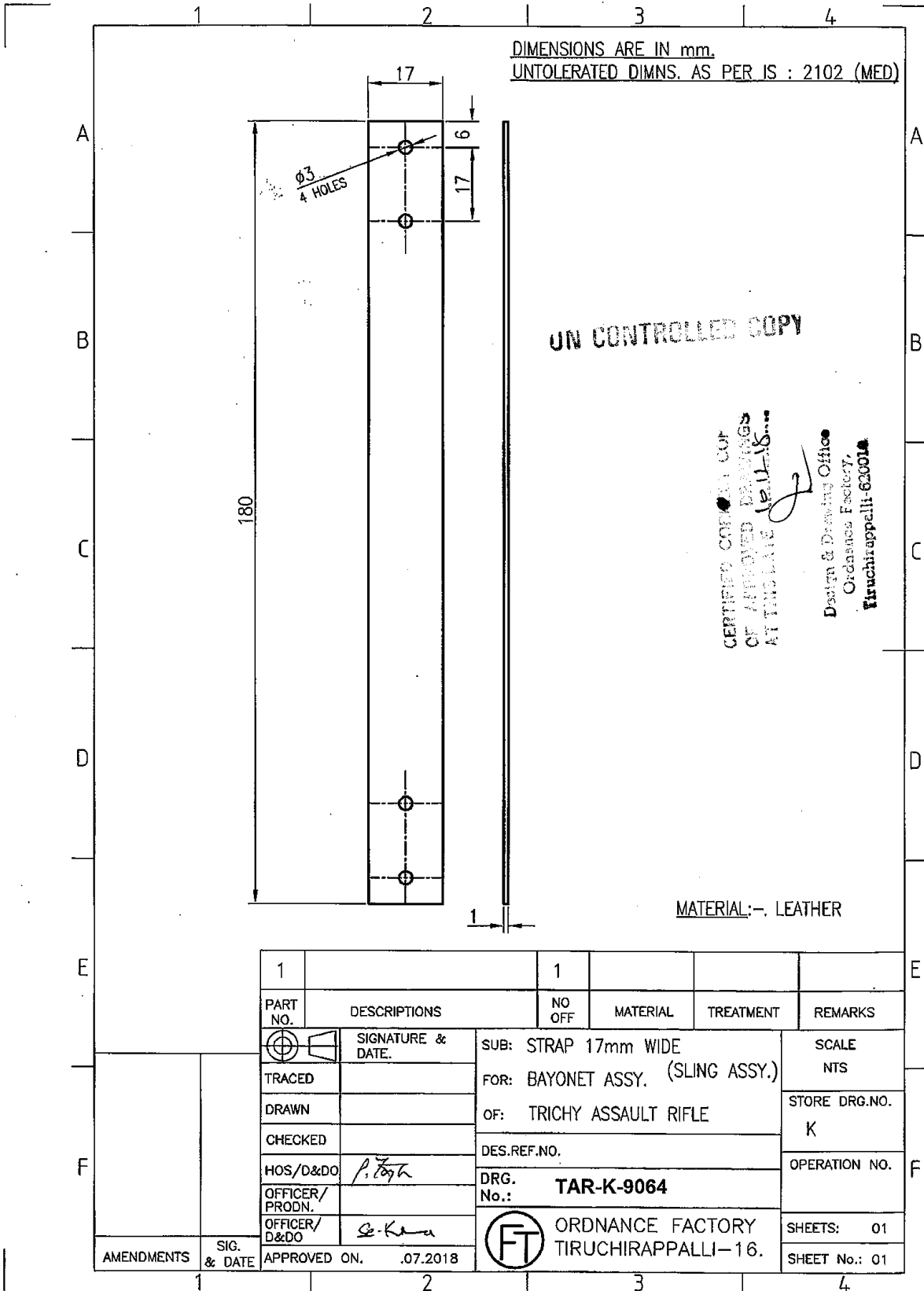

DIMENSIONS ARE IN mm.  
 UNTOLERATED DIMNS. AS PER IS : 2102 (MED)

PROTECTIVE FINISH :- PHOSPATED TO SPEC:  
 JSS:0465-01-1988 CLASS-I (ACCELERATED) OIL FINISH.

UN CONTROLLED COPY

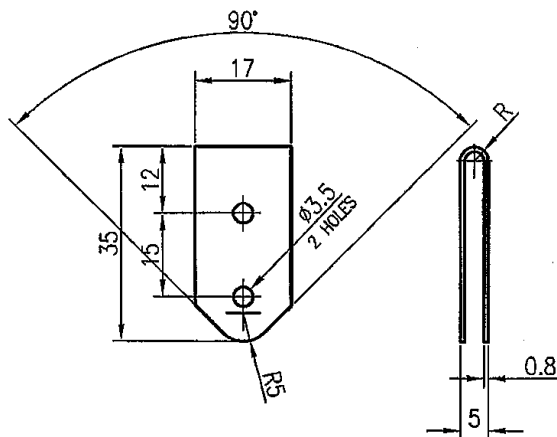

18.11.18  
*[Signature]*

MATERIAL:- BS 1449 Pt.1:1983 Gr. CS3  
 BS 1449 Pt.1:1983 Gr. CS4  
 IS 513 : 2008 Gr. CR1  
 IS 513 : 2008 Gr. CR2

1		1			
PART NO.	DESCRIPTIONS	NO OFF	MATERIAL	TREATMENT	REMARKS
	SIGNATURE & DATE.	SUB: PLATE FOLDED (SLING ASSY.)			SCALE NTS
	TRACED	FOR: BAYONET ASSY.			STORE DRG.NO. K
	DRAWN	OF: TRICHY ASSAULT RIFLE			OPERATION NO.
	CHECKED	DES.REF.NO.			
	HOS/D&DO <i>P. Jey</i>	DRG. No.: <b>TAR-K-9063</b>			
	OFFICER/PRD.N.	ORDNANCE FACTORY TIRUCHIRAPPALLI-16.			SHEETS: 01
	OFFICER/D&DO <i>Ge. K...</i>				SHEET No.: 01
AMENDMENTS	SIG. & DATE	APPROVED ON.	.07.2018		

DIMENSIONS ARE IN mm.  
 UNTOLERATED DIMNS. AS PER IS : 2102 (MED)  
 PROTECTIVE FINISH :- PHOSPATED TO SPEC:  
 JSS:0465-01-1988 CLASS-I (ACCELERATED) OIL FINISH.

UN CONTROLLED COPY

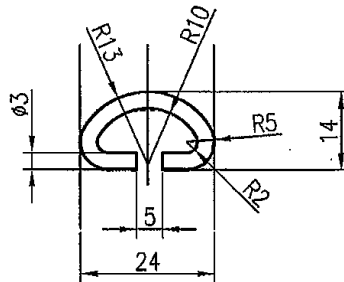

8-11-18

HEAT TREATMENT :

NOTE: SPRING STEEL WIRE TO BE TEMPERED BEFORE BENDING

MATERIAL:- IS: 4454 Pt.1 2001 Grade-DH

1	1	1	1	1	1
PART NO.	DESCRIPTIONS	NO OFF	MATERIAL	TREATMENT	REMARKS
	SIGNATURE & DATE.	SUB: BUCKLE (SLING ASSY.)		SCALE NTS	
	TRACED	FOR: BAYONET ASSY.		STORE DRG.NO. K	
	DRAWN	OF: TRICHY ASSAULT RIFLE		OPERATION NO.	
	CHECKED	DES.REF.NO.			
	HOS/D&DO <i>P. Ash</i>	DRG. No.: <b>TAR-K-9062</b>			
	OFFICER/PRDN.	 ORDNANCE FACTORY TIRUCHIRAPPALLI-16.		SHEETS: 01	
	OFFICER/D&DO <i>B. K. ...</i>			SHEET No.: 01	
AMENDMENTS	SIG. & DATE	APPROVED ON.	.07.2018		

UN CONTROLLED COPY

DIMENSIONS ARE IN mm.  
 UNTOLERATED DIMNS. AS PER IS : 2102 (MED)  
 PROTECTIVE FINISH :- PHOSPATED TO SPEC:  
 JSS:0465-01-1988 CLASS-I (ACCELERATED) OIL FINISH.

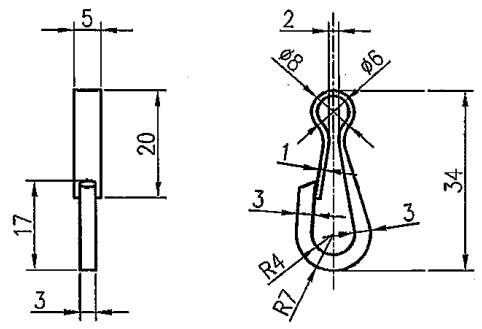

HEAT TREATMENT :  
 NOTE: SPRING STEEL WIRE TO BE TEMPERED & FLATTENED  
 (WHEREVER REQUIRED) BEFORE BENDING  
MATERIAL:- IS: 4454 Pt.1 2001 Grade-DH

1		1			
PART NO.	DESCRIPTIONS	NO OFF	MATERIAL	TREATMENT	REMARKS
	SIGNATURE & DATE.	SUB: SPRING HOOK (SLING ASSY.)			SCALE NTS
	TRACED	FOR: BAYONET ASSY.			STORE DRG.NO.
	DRAWN	OF: TRICHY ASSAULT RIFLE			K
	CHECKED	DES.REF.NO.			OPERATION NO.
	HOS/D&DO <i>P.Tank</i>	DRG. No.: <b>TAR-K-9061</b>			
	OFFICER/PRODN.	 ORDNANCE FACTORY TIRUCHIRAPPALLI-16.			SHEETS: 01
	OFFICER/D&DO <i>CK</i>				SHEET No.: 01
AMENDMENTS	SIG. & DATE	APPROVED ON. .07.2018			



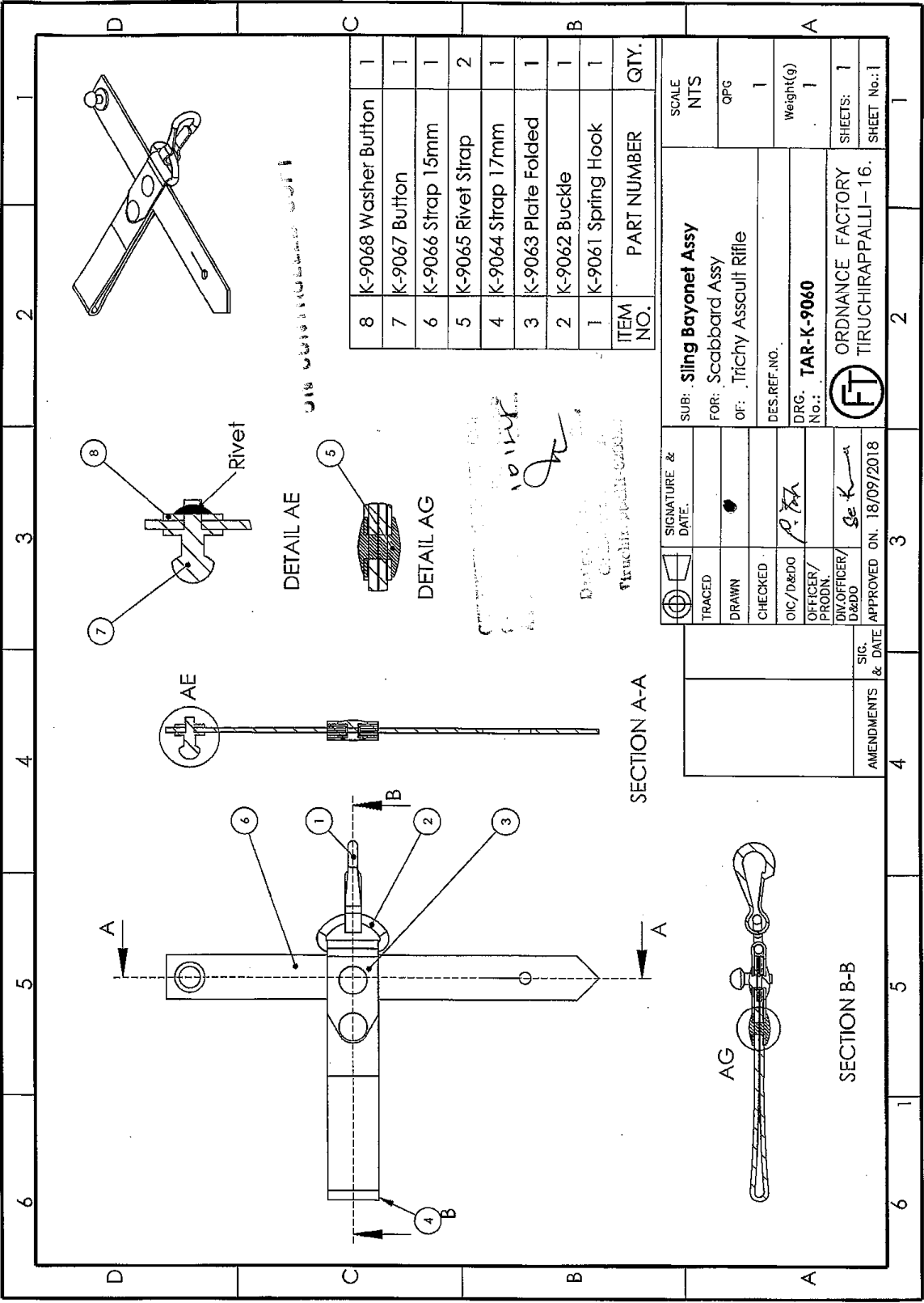

ITEM NO.	PART NUMBER	QTY.
8	K-9068 Washer Button	1
7	K-9067 Button	1
6	K-9066 Strap 15mm	1
5	K-9065 Rivet Strap	2
4	K-9064 Strap 17mm	1
3	K-9063 Plate Folded	1
2	K-9062 Buckle	1
1	K-9061 Spring Hook	1

SUB: Sling Bayonet Assy	SCALE NTS
FOR: Scabbard Assy	OPG
OF: Trichy Assault Rifle	1
DES. REF. NO.	Weight(g)
DRG. No.: TAR-K-9060	1
ORDNANCE FACTORY TIRUCHIRAPPALLI-16.	
SHEETS: 1	
SHEET No.: 1	

SIGNATURE & DATE.	TRACED	SCALE
	DRAWN	NTS
	CHECKED	OPG
	OIC/D&DO	Weight(g)
	OFFICER/PRODN.	1
	DIV. OFFICER/D&DO	
APPROVED ON: 18/09/2018		

AMENDMENTS & DATE	SIC. & DATE

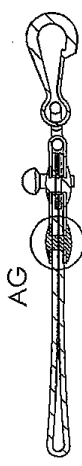

SECTION B-B

SECTION A-A

DETAIL AE

DETAIL AG

JTB

*DRG: P. J. S.*  
*DATE: 18/09/2018*

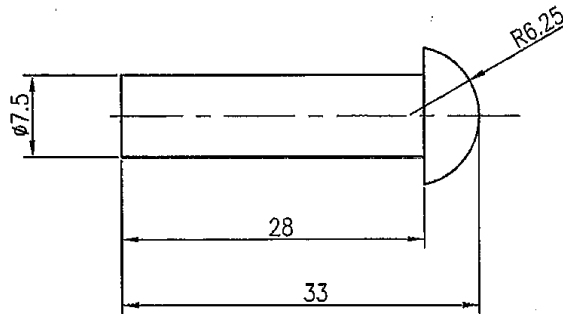

DIMENSIONS ARE IN mm.  
 UNTOLERATED DIMENSIONS AS PER IS:2102(MED)  
 PROTECTIVE FINISH :- PHOSPATED TO SPEC:  
 JSS:0465-01-1988 CLASS-I (ACCELERATED) OIL FINISH.

UN CONTROLLED COPY



CERTIFIED COPY OF  
 ORIGINAL DRAWING  
 AT THE DRAWING OFFICE  
 Design & Drawing Office  
 Ordnance Factory,  
 Tiruchirappalli-620016

MATERIAL:- IS 226-1975 (OR) IS 2062- 2011  
 (ANY GRADE E-250,275,300,350,410,450,550,600,650)  
 IS 2155-1962  
 (CHEMICAL COMP. MATCH TO IS:7557-1974)

PART NO.	DESCRIPTIONS	NO OFF	MATERIAL	TREATMENT	REMARKS
		1			
	 SIGNATURE & DATE. TRACED DRAWN CHECKED HOS/D&DO <i>P. Toth</i> OFFICER/PRODN. OFFICER/D&DO <i>G. K. R.</i>		SUB: RIVET BAYONET (BLADE ASSY) FOR: BAYONET ASSY. OF: TRICHY ASSAULT RIFLE DES.REF.NO. DRG. No.: <b>TAR-K-9045</b>		SCALE NTS STORE DRG.NO. K 9045 OPERATION NO.
AMENDMENTS	SIG. DATE	APPROVED ON.	 ORDNANCE FACTORY TIRUCHIRAPPALLI-16.		SHEETS: 01 SHEET No.: 01